

MUELLER® FALLING FILM CHILLERS



MUELLER® FALLING FILM CHILLERS ARE DESIGNED TO COOL ANY FLUID TO WITHIN 2°F OF ITS FREEZE POINT.

The primary application for Mueller's falling film chiller is to cool food-grade liquids that will become an ingredient in a food product, or that will come into contact with a food product.

Other applications include cooling fluids that have an initial temperature of more than 80°F. This task cannot be accomplished in most conventional chillers.

MUELLER®
REFRIGERATION PRODUCTS

The Chilling Solution

To qualify as a food-grade chiller, the chiller must meet USDA and FDA requirements. The following are a few important issues to consider:

- ◆ An acceptable material for construction must be chosen.
- ◆ All product contact surfaces shall be visible for inspection.
- ◆ All product contact surfaces shall be smooth and free of pits, crevices, and scale.
- ◆ The product zone shall be free of recesses, open seams, and gaps.
- ◆ All internal corners or angles in the product zone shall have a smooth and continuous radius of $\frac{1}{4}$ " or greater.
- ◆ Equipment shall be capable of draining all of the fluid it holds.
- ◆ Gaskets and O-rings must be made of approved food-grade material.

The falling film chiller was designed to meet all of these requirements and provide you with the chilling solution to all your chilling requirements.

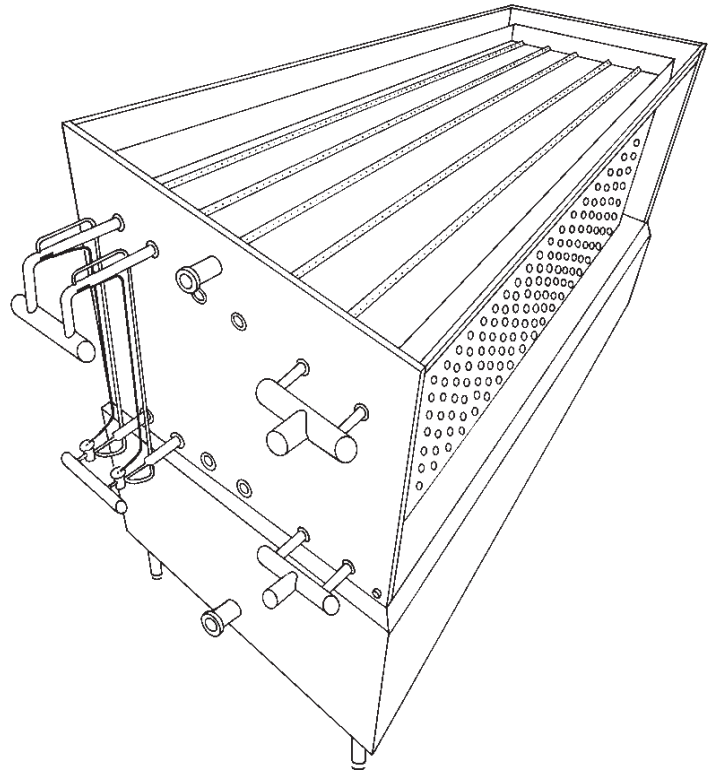

Chiller Components

Cabinet

Cabinets are available in designs to meet your specific chilling requirements. Standard units are built to accommodate the following: (8) 3 x 5 plates or (8, 16, 24, and 32) 4 x 8 plates.

Construction Features

Standard units are constructed of Type 304 stainless steel with a 2B finish. All welds are blasted with glass beads. Optional materials are available upon request, including 316L and AL6XN, as well as others. Optional finishes include No. 4 food-grade finish and electro-polish for ultra-high purity or corrosive applications, as well as others.

Evaporator

The evaporator allows water to be chilled as low as 34°F and other solutions to within one or two degrees of their freeze points with no freeze-up problems or chiller damage.

Multi-size evaporators are available to meet specific load requirements (3 x 5 and 4 x 8). Evaporator plates are circuited to maintain proper oil return and ensure maximum refrigeration efficiency.

The system is suitable for use with R-22, R-404A, R-134A, and ammonia refrigerants as well as most new non-CFC refrigerant products in flooded, recirculated, or direct-expansion systems. Built to ASHRAE 15 standards, the system is rated at 300 psi at 400°F. Optional ASME code-stamped evaporators are available.

Fill Connection

Chillers are equipped with a threaded fill connection which allows for the use of electronic level controls. The fill connection is located on the water pan inlet.

Optional Refrigeration Manifolding

Optional manifolding is available for all types of refrigerants. When direct expansion refrigeration systems are used, manifolding includes the mounting of required expansion valves. Copper or stainless steel would be the ideal material to choose.

Overflow Connections

All chillers are equipped with a female, threaded overflow connection, which allows for simple piping of excess fluid.

Tank Reservoir

Standard tank sizes are available from 190 to 1,400 gallons. The holding tank is insulated with a minimum of 2-inch insulation for elimination of heat loss and condensation buildup.

A sloped bottom allows for complete drainage of the holding tank. Adjustable legs enable the chiller to sit level on uneven surfaces for proper operation of the distribution pan and allow an even laminar flow pattern over the evaporator plates for maximum cooling efficiency.

Water Distribution Pan

The distribution pan has holes over each vertical evaporator plate to allow a thin, uniform solution to flow over both sides of each plate. The hole size and spacing are determined by the flow rate requirements for each chilling application.

Pans are available in extra low, low, and high flow. Minimum flow is 1.2 gpm per linear foot of plate with a maximum flow rate of 6.2 gpm per linear foot of plate.

Features and Benefits

Standard Option Concept

The falling film chiller product was designed around the standard option concept to enable us to improve quotation lead time, delivery time, and lower cost.

This concept has allowed us to pre-design the entire product line once, which eliminates the unnecessary cost of re-engineering a custom product for each order.

By taking the time to evaluate the needs of all of our different customers, we were able to design all of the needed options. This also makes it unnecessary for our customers to pay for something on their chiller they do not need. These two advantages provide you with the lowest cost and the shortest lead time in the industry.

Cabinet Sizes

We currently build two chiller sizes, 3 x 5 and 4 x 8. The 3 x 5 chiller is available in an 8-plate cabinet. The 4 x 8 chiller is available in an 8-, 16-, 24-, and 32-plate cabinet. Each of these chillers has a tank that was properly sized to satisfy the requirements of the chiller.

We also offer a tankless chiller cabinet in the following sizes: 8-plate 3 x 5, 8-plate 4 x 8, 16-plate 4 x 8, and 24-plate 4 x 8.

Cabinet Top Options

Each cabinet is available with a welded in place top or a top fitted with a hinged door over each distribution pan.

The above options allow for access (or not) to the top of the chiller, depending upon your needs.

Cabinet Expandability

Adding additional plates (up to cabinet capacity) is nearly effortless due to the advanced cabinet design of all of our chillers. So, be sure to select a cabinet that allows for future expansion when you are ready to buy your next chiller. When expansion time comes, you will only have the cost of additional plates and distribution pans, not a second chiller which requires an expensive installation.

Evaporator Features and Options

We offer 3 x 5 and 4 x 8 plate sizes. Each plate size is available for DX, recirculated, and flooded refrigerant controls for R-717, R-22, R-404A, and all other conventional refrigerants.

Due to the plate design, no special refrigerant controls are necessary, nor are you forced to select flooded controls when DX would be less expensive and a better fit for your application.

All plates are built to ASHRAE 15 standards rated at 300 psi at 400°F. Optional ASME plates at the same rating are available.

Evaporator Internal Plate Capacity

Mueller's patented Temp-Plate® is the most efficient falling film chiller evaporator available today. Each evaporator is designed to use the smallest refrigerant charge possible and is circuited to ensure that the entire evaporator operates at the correct temperature. The internal volume is .15 cubic feet for the 3 x 5 plate and .42 cubic feet for the 4 x 8 plate. These capacities are 8 to 10 times less than others.

Tank Connection Options

Each chiller is laid out with multiple locations for tank connections. This option allows you to pick the location and any standard size connection for your chiller. You can select the connection size and location from our list of standard connections located on the submittal drawing for each cabinet.

Refrigerant Controls

We provide DX and flooded refrigerant controls for all refrigerants. For details on the individual components, review the *Falling Film Chiller Operations and Installation Manual*.

Water Level Control Option

All Mueller falling film chillers are equipped with a 1/4" connection to allow for the installation of an optional water level control. This control will allow you to set the upper and lower level anywhere you choose.

There are three optional control panels which allow you to set the level control. The three components needed to operate the level control are the pressure transducer, a 1" water solenoid valve, and one of the optional control panels described in the "Control Panel Options" section.

Control Panel Options

We offer three standard control panels. The following is a brief description of each panel.

Model 100 Control Panel

The Mueller Model 100 chiller control is designed to control chiller water temperature. It requires 230/60/1 electrical input. Outputs to control temperature are 24-volt to operate a refrigeration unit, chiller circulation pump, process circulation pump, and optional water level control and fill solenoid valve.

Model 200 Control Panel

The Mueller Model 200 chiller control is designed to control chilled water temperature. The chiller control will accommodate 208/60/3, 230/60/3, or 460/60/3 electrical input. Outputs to control temperature are 24-volt and can operate up to four stages of refrigeration. It will also control the operation of a chiller circulation pump (up to 5 hp), a process circulation pump (up to 5 hp), and optional water level control and fill solenoid valve.

Level Control Panel

This board is mounted in the 6" x 6" level control box and can be used to set up the reservoir level to control the water fill valve.

Refrigeration Units

We offer a complete line of condensing units that have been designed to match the performance requirements of the falling film chiller. These units are available in outdoor air-cooled, water-cooled, and remote air-cooled (with outdoor) condensers. Each type of unit is available in horsepower sizes from 5 to 120 hp. Some sizes may not be available in all types.

Specially Designed High Sides

Custom high sides of all sizes and configurations are available upon request.

Quotation Lead Time

For quotations on chillers with standard options, the normal lead time is 24 hours or less from the time we receive your request. Requests for quotes that include no standard options may take longer.

Order Lead Time

The normal shipment lead time after the receipt of an order is four weeks. Some orders with special requirements may take up to two weeks longer.

*Quality, price,
and service...
Mueller provides
all three!*

Options, Accessories, & Other Equipment

Refrigerant Controls

Refrigerant controls for ammonia and other refrigerant including direct expansion, flooded, and recirculated systems are available.

Refrigerant Circuit Manifolds

Refrigerant circuit manifolds are available to simplify installation. Manifolds for DX systems include valves and external equalizers already mounted. Flooded and recirculated manifold are available in copper and stainless steel materials.

Additional Equipment

Surge drums, receivers, hand valves, and other refrigerant accessories are available upon request.

Temperature Control Assemblies

Temperature control packages are available to control temperature, circulating pumps, and make-up water levels.

Pumps

Circulating pumps are available in various flow ranges and materials to suit your needs.

Condensing Units

Condensing units (semi-hermetic and scroll compressors) are available in air-cooled, remote air-cooled, or water-cooled models.



3 x 5 Chillers



The Mueller 3 x 5 falling film chiller reduces chilling time, increases production, and brings a faster return on your investment.

The Mueller 3 x 5 falling film chiller is designed with a fully welded cabinet which includes a hinged and gasketed door for access. Built for lower-capacity applications, the unit is equipped with a 190- or 400-gallon self-contained storage tank.

Distribution pans are available with extra-low, low, and high flow rates, based on chilled water usage. Extra-low flow rates range from 4 to 10 gpm, low flow rates range from 8 to 15 gpm, and high flow rates range from 16 to 30 gpm (per evaporator).

3 X 5 CHILLER SIZING CHART

Cabinet Size	No. of Plates		Dimensions L x W x H (in)	Maximum Shipping Weight (lbs)	Tank Capacity (gal)	Distribution Pan Connection Size
	Minimum	Maximum				
N	2	8	68 ¹ / ₂ x 36 ¹ / ₂ x 77 ³ / ₄	1,820	190	2" or 3"
O	2	8	68 ¹ / ₂ x 36 ¹ / ₂ x 97 ³ / ₄	2,020	400	2" or 3"

Notes:

- ◆ Refrigerant inlet connection size per plate is 1¹/₈" tube and the outlet size is 1¹/₂" tube.
- ◆ Maximum weight is based on the maximum number of plates that a chiller will hold being in the chiller.
- ◆ Low flow/extra-low flow distribution pan connection is 2".
- ◆ High flow distribution pan connection is 3".

4 x 8 Chillers

Fully enclosed design eliminates product contamination.

The Mueller 4 x 8 enclosed-type falling film chiller is fully enclosed to ensure your product is free from airborne particles. The unit is easily accessible through gasketed doors and is designed for large-capacity chilling applications.

Distribution pans are available in extra-low, low, and high flow rates, based on chilled water usage. Extra-low flow rates range from 6 to 16 gpm, low flow rates range from 13 to 24 gpm, and high flow rates range from 25 to 48 gpm (per evaporator).



4 X 8 CHILLER SIZING CHART

Cabinet Size	No. of Plates		Dimensions L x W x H (in)	Maximum Shipping Weight (lbs)	Tank Capacity (gal)	Distribution Pan Connection Size
	Minimum	Maximum				
J	2	8	104 ¹ / ₂ x 39 ¹ / ₈ x 90 ³ / ₄	2,735	361	4" or 6"
K	2	16	104 ¹ / ₂ x 72 ³ / ₈ x 90 ³ / ₄	5,220	706	(2) 4" or 6"
L	2	24	104 ¹ / ₂ x 105 ⁷ / ₈ x 90 ³ / ₄	7,705	1,052	(3) 4" or 6"
M	2	32	104 ¹ / ₂ x 139 x 90 ³ / ₄	10,190	1,397	(4) 4" or 6"

Notes:

- ◆ Refrigerant inlet connection size per plate is 1¹/₈" tube and the outlet size is 2" pipe.
- ◆ Maximum weight is based on the maximum number of plates that a chiller will hold being in the chiller.
- ◆ Low flow and extra-low flow distribution pans have a 4" connection and high flow pans have a 6" connection.

4 x 8 Chillers



Back View (left)

Gasketed door with latches make the chiller easily accessible for inspection and servicing.

Outlet connections are available in various sizes and piping configurations.



Top View

Optional top doors are available for accessibility to the distribution pan for needed cleaning.



Inlet Connection

Inlet connection is shown here with optional make-up water valve.



Overflow Connection

Each chiller has an overflow connection to guard against over filling the reservoir.



Water Level Control

Optional water level sensor is available if needed.

Tankless Chillers

Versatility to match your specific storage needs.

Mueller's tankless chiller is designed for applications where it is necessary to place the chiller over the top of an existing tank.

Distribution pans are available in extra-low, low, and high flow.

Units are available in both 3 x 5 and 4 x 8 evaporators from 8- to 24-plate cabinets.



TANKLESS CHILLER SIZING CHART

Cabinet Size	L x W x H (in)	Weight with Plates (lbs)	Refrigeration Connection Size Inlet*	Refrigeration Connection Size Outlet*	Water Pan Connection Size
8 - 3 x 5	70 x 43 x 48	990	1 ¹ / ₈ " Tube	1 ¹ / ₂ " Tube	2" or 3" MPT
8 - 4 x 8	108 x 43 x 62	1,550	1 ¹ / ₈ " Tube	2" Pipe	4" or 6" MPT
16 - 4 x 8	108 x 67 x 62	2,980	1 ¹ / ₈ " Tube	2" Pipe	(2) 4" or 6" MPT
24 - 4 x 8	108 x 104 x 62	4,220	1 ¹ / ₈ " Tube	2" Pipe	(3) 4" or 6" MPT

Note:

**Inlet and outlet connection sizes are per plate connection sizes.*

Falling Film Chiller Model No. Breakdown

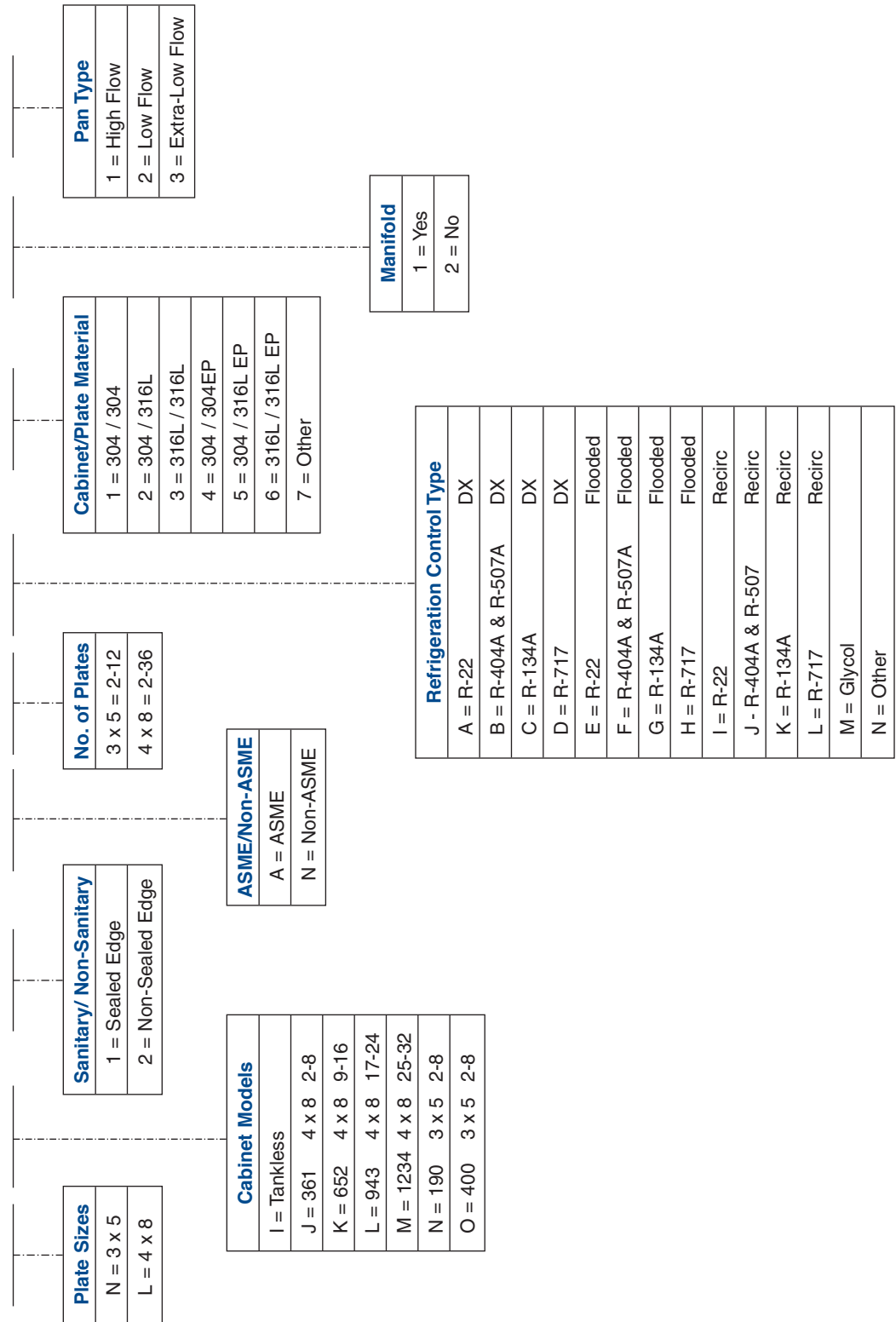

P.O. Box 828 • Springfield, Missouri 65801-0828, U.S.A.
 Phone: (417) 831-3000 • 1-800-MUELLER • Fax: 1-800-436-2466
 www.muel.com • E-mail: refrigeration@muel.com

International Inquiries—Fax: (417) 831-6906 • E-mail: international@muel.com

©1998-2005 Paul Mueller Company



CR-1225-5