



**CP**

Vent Sets | Product Guide |



**LOREN COOK COMPANY**

# INTRODUCTION



Cook's CP family of centrifugal utility vent sets offers durability, reliability and flexibility to meet a wide range of needs and budgets. CPs are ideal for low to medium volume and pressure applications.

## ESSENTIAL ADVANTAGES



### DESIGNED FOR

supply, exhaust or return air movement applications



### FIELD ROTATABLE

housing is standard on all models.



### PERFORMANCE RANGE

50-53,500 CFM



### STATIC PRESSURES

up to 8" w.g.



### CHOOSE FROM

different wheel types: CPF, CPS, CPS-A, CPA, CPA-A, & CPV



### FULLY WELDED HOUSING

to prevent leakage



### HIGH TEMP

Standard construction is rated to 230°F



### SPARK RESISTANCE

CPA and CPA-A have an aluminum housing and wheel making them standard AMCA A.



## EXTRA BENEFITS

- ▶ CP models are licensed to bear the AMCA Certified Rating Seals
- ▶ UL 705 is standard on all CP models
- ▶ Discharge flanges are standard on all models except down blast and CPF
- ▶ Available with Vari-Flow® motors and controls



For more information, Look at the Vari-Flow® Product Guide or contact Loren Cook Company at 417-869-6474.



# CENTRIFUGAL WHEEL



Centrifugal wheels have been the workhorse of the fan industry for over 100 years. Their versatility, energy-efficiency and availability are viable solutions for a wide range of applications.

## CENTRIFUGAL WHEEL ADVANTAGES

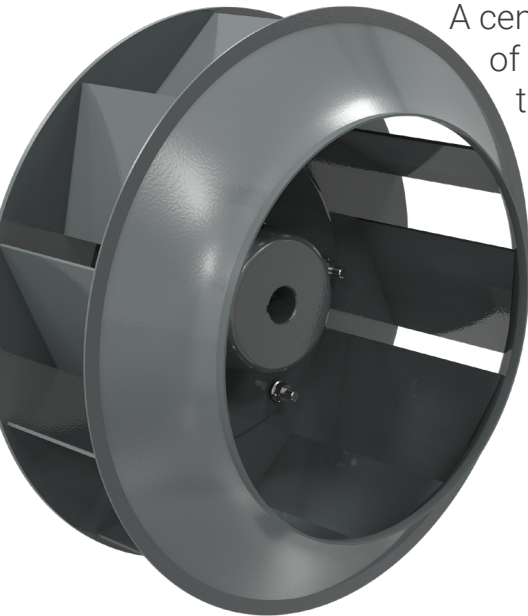

A centrifugal wheel brings air in parallel to the axis of rotation and discharges air perpendicular to the axis of rotation. The air then follows the shape of the fan to the outlet. As a general rule, it is preferred for higher pressure exhaust and ducted systems. Cook offers three CP blade types explained on the next page.

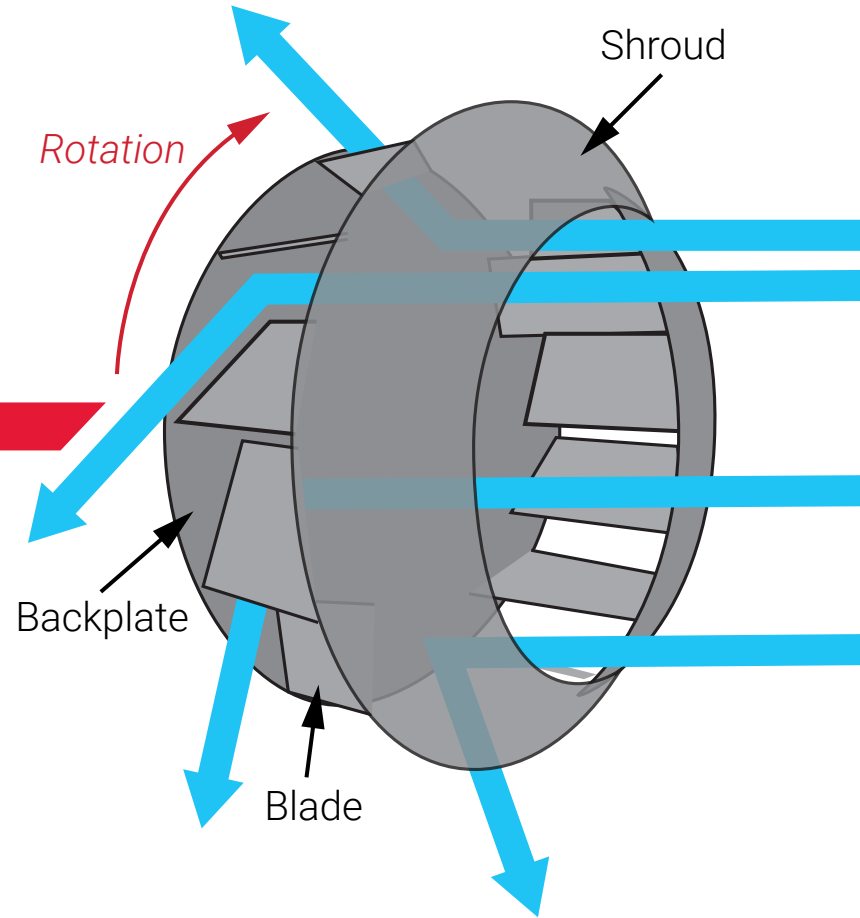

*Shown from the inlet side  
(opposite the drive shaft)*

# BLADE COMPARISON



There are three primary centrifugal wheel designs.  
Each one has its strengths.

## BACKWARD INCLINED AIRFOIL

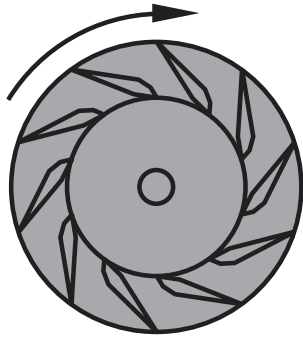

- ▶ Highest efficiency of the CP impeller designs
- ▶ Blades of airfoil contour curved away from the direction of rotation
- ▶ Air leaves the impeller at a velocity less than its tip speed
- ▶ Relatively deep blades provide efficient expansion within the blade passages

## BACKWARD INCLINED FLAT BLADE

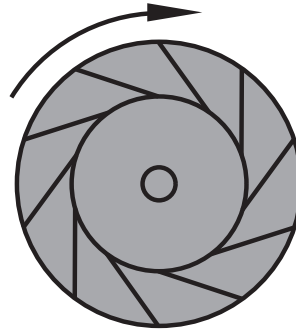

- ▶ Efficiency is slightly less than that of the airfoil design
- ▶ Blades are single thickness metal inclined away from the direction of rotation
- ▶ Air leaves the impeller at a velocity less than its tip speed
- ▶ Relatively deep blades provide efficient expansion within the blade passages
- ▶ Less expensive than airfoil

## FORWARD CURVED

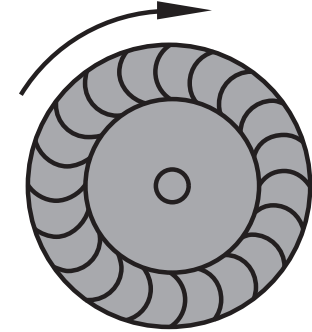

- ▶ Efficiency is less than airfoil and backward inclined impellers
- ▶ Has blades with both the heel and tip curved forward
- ▶ Air leaves the impeller at velocities greater than the impeller tip speed
- ▶ Operates most efficiently at lowest speed
- ▶ Good for low pressure applications

# WHEEL COMPARISON



The CPV, CPS/CPA, CPS-A/CPA-A and CPF are each designed for a specific performance range. The curves chart below illustrates typical performance ranges of the different wheel designs.

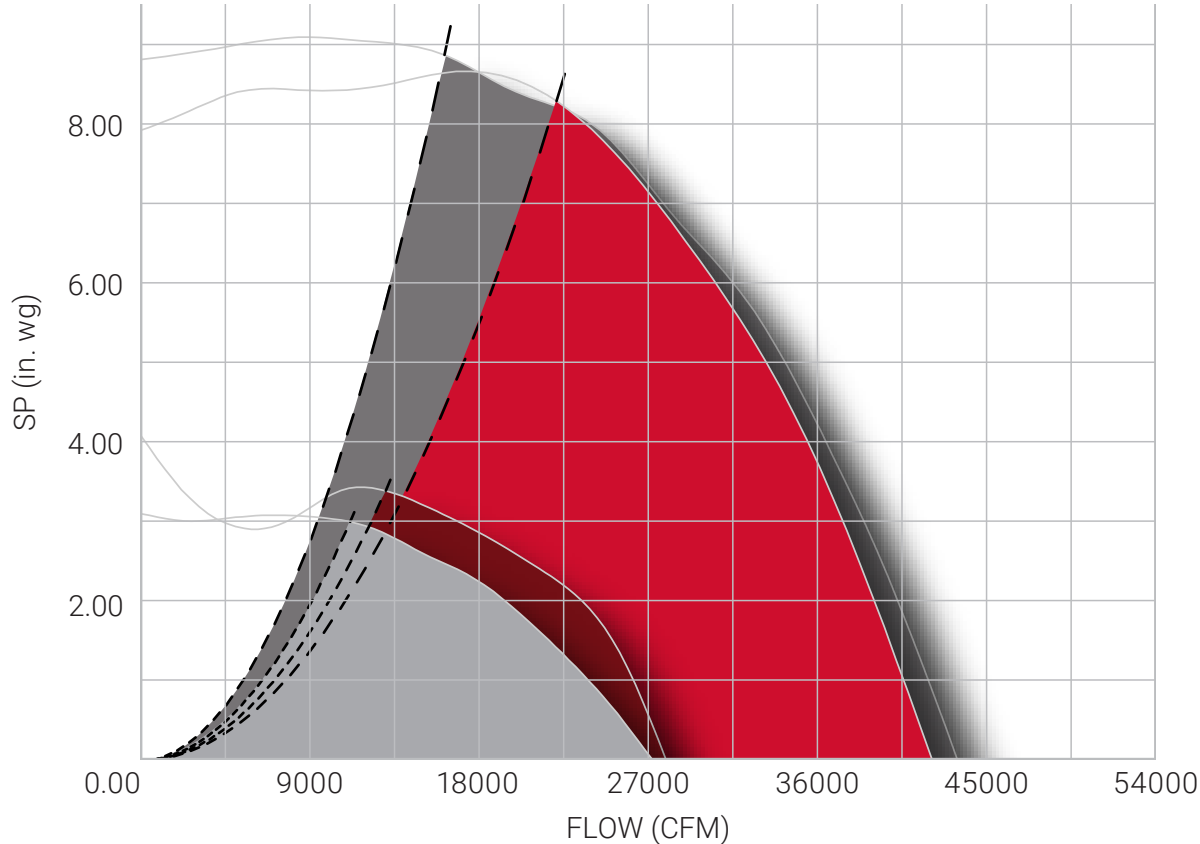

## CPF

- ▶ CPF & CPFB use a steel wheel with forward curved blades.



## CPV

- ▶ CPV uses a riveted aluminum wheel with weld between backward inclined flat blades and shroud.

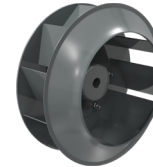

## CPA/CPS

- ▶ CPS uses a welded, Lorenized™ steel wheel with backward inclined flat blades.
- ▶ CPA uses a welded, aluminum wheel with stainless steel hardware.

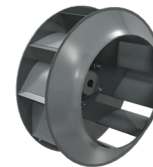

## CPA-A/CPS-A

- ▶ CPS-A uses a welded, Lorenized™ steel wheel with backward inclined airfoil blades.
- ▶ CPA-A uses a welded aluminum wheel with backward inclined airfoil blades and stainless steel hardware.

# STANDARD CONSTRUCTION FEATURES



Arrangement 10 standard construction features are shown below.

## CPV/CPFB/CPS/CPS-A

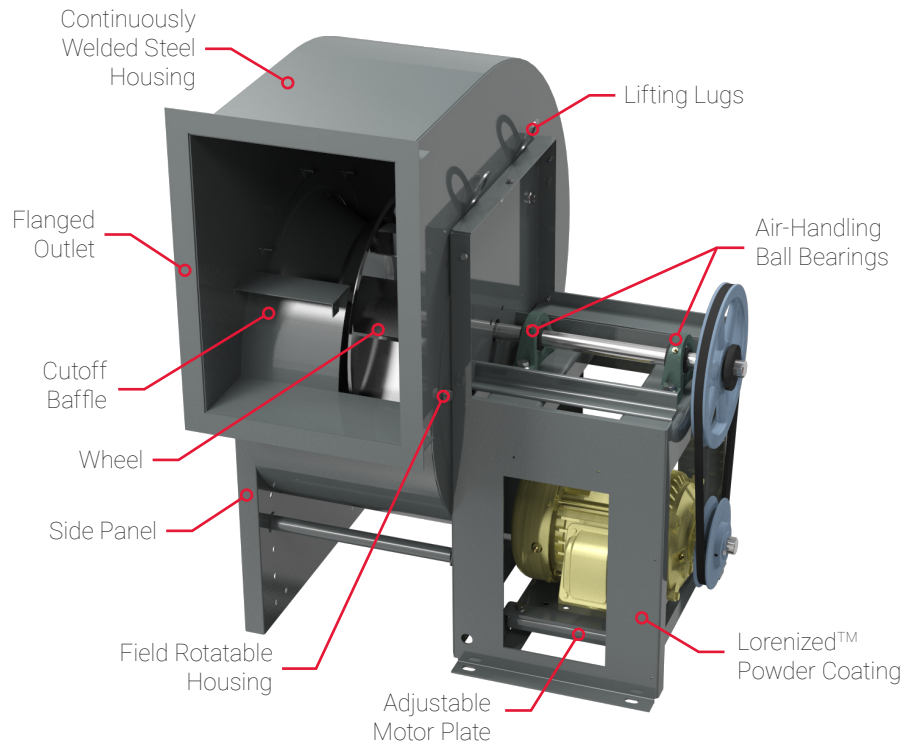

## CPA/CPA-A

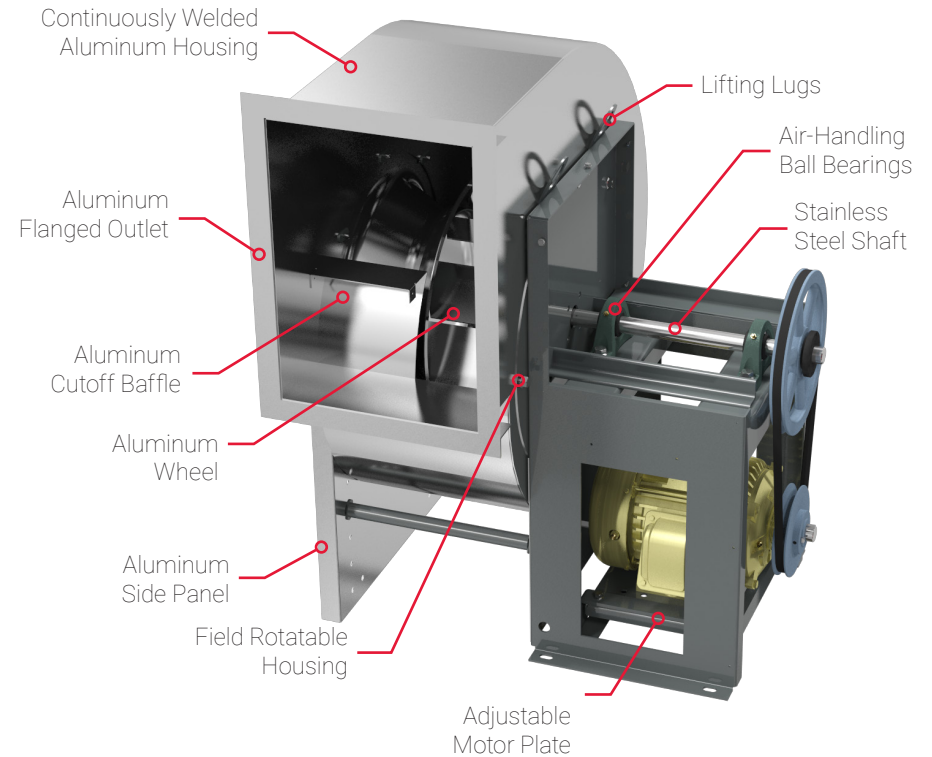



# STANDARD CONSTRUCTION FEATURES



Arrangement 4 standard construction features are shown below.

## CPV WITH EC MOTOR

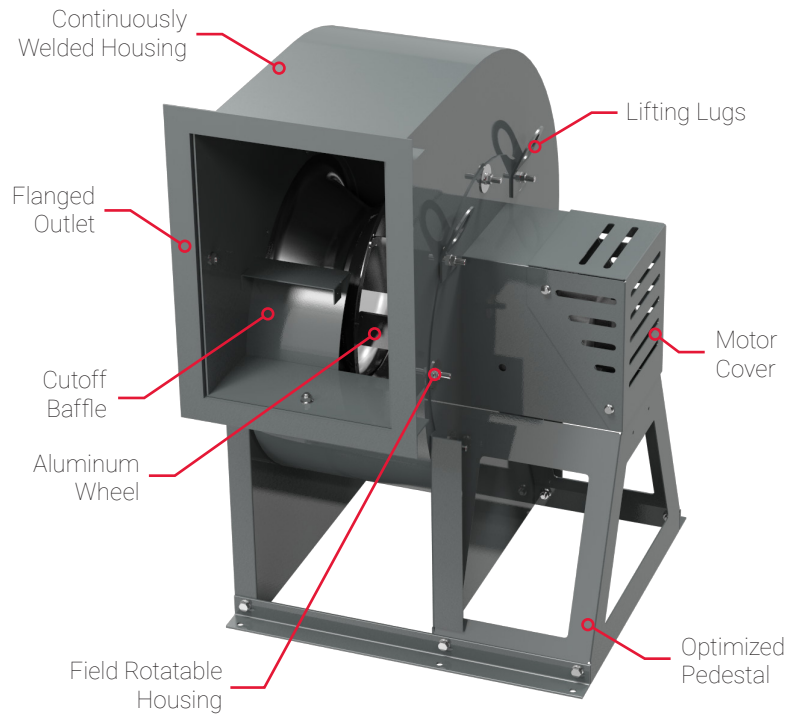

## CPFD

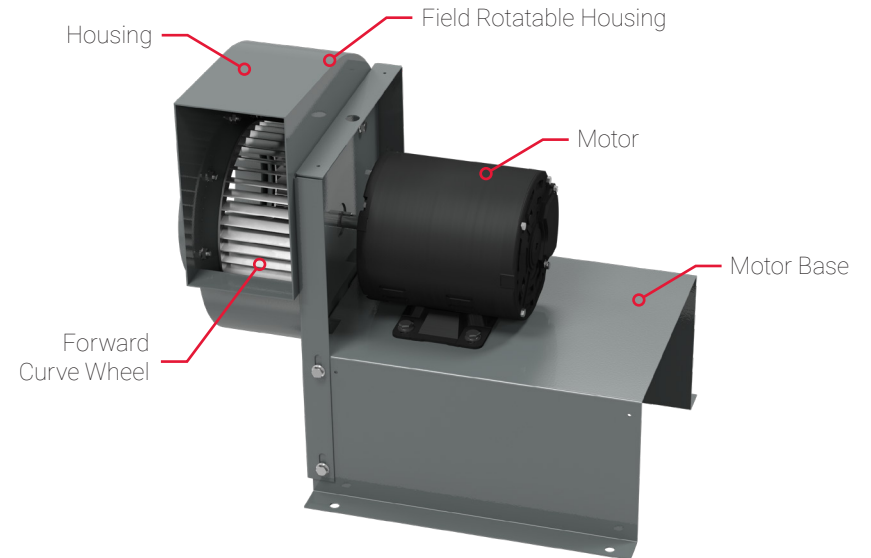

# ROTATION AND DISCHARGE



CP's are offered in Clockwise and Counterclockwise rotation. The CP housing is field rotatable allowing you to adjust to any of 7 positions\*

## ROTATION

- ▶ The direction of rotation is determined from the drive side of the fan. On single inlet fans, drive side is always considered as the side opposite the fan inlet.

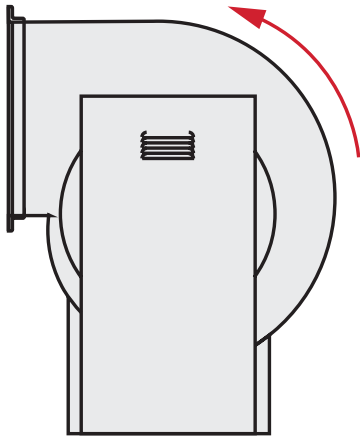

**Counterclockwise**

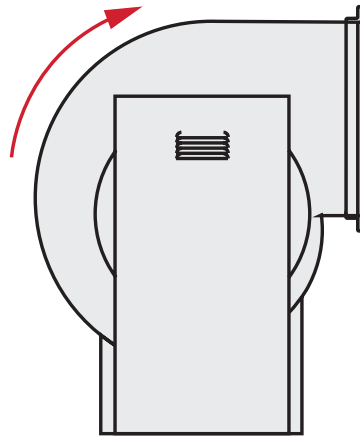

**Clockwise**

## DISCHARGE

- ▶ The discharge designation is based on the horizontal axis of the fan and is designated in degrees (45° standard) above or below the axis of rotation.

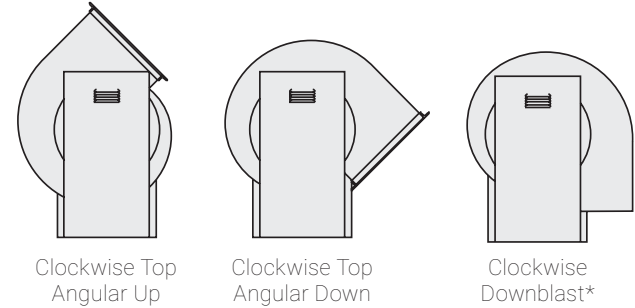
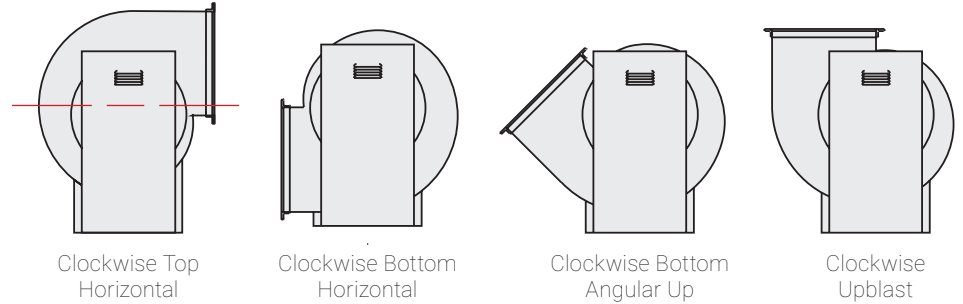

\*Class 1 only



# CP ACCESSORIES



Beyond the CP Standard Construction Features, Cook offers accessories to fit your custom air-movement requirements and/or preferences.

## ARRANGEMENT 10

### ACCESS DOOR

- ▶ Available bolted or hinged
- ▶ Provides access for cleaning and inspection
- ▶ Material same as the fan housing
- ▶ Gasket is utilized to minimize leakage

### BELT GUARD

- ▶ Designed to cover the shaft and drive components
- ▶ Constructed 16 gauge (min) Lorenized™ steel
- ▶ Factory Mounted
- ▶ OSHA belt guards are available to completely enclose shaft and drive components

### INLET/OUTLET SAFETY SCREENS

- ▶ Protect personnel and prevent debris from entering the fan in non-ducted applications
- ▶ Factory mounted

### DRAIN

- ▶ Optional drain is located in the bottom of the fan housing
- ▶ Continuously welded to the housing and threaded for a 3/4 inch pipe connection

### WEATHER COVER

- ▶ Completely encloses the motor, shaft and drive components
- ▶ Constructed of 16 gauge (min) Lorenized™ steel
- ▶ Functions as an OSHA belt guard

### FLANGED INLET

- ▶ For flange-type duct attachments.
- ▶ Allows fan removal without disturbing the surrounding ductwork

### INLET/OUTLET COMPANION FLANGE

- ▶ For use with the flanged outlet and optional flanged inlet
- ▶ Attached to the adjacent ductwork to mate to the flanged connection of the fan

### ISOLATION RAILS

- ▶ Supplied in pairs, and are designed to run the full length of the supported equipment (parallel to shafts)
- ▶ *See [Vibration Isolation brochure for details](#)*

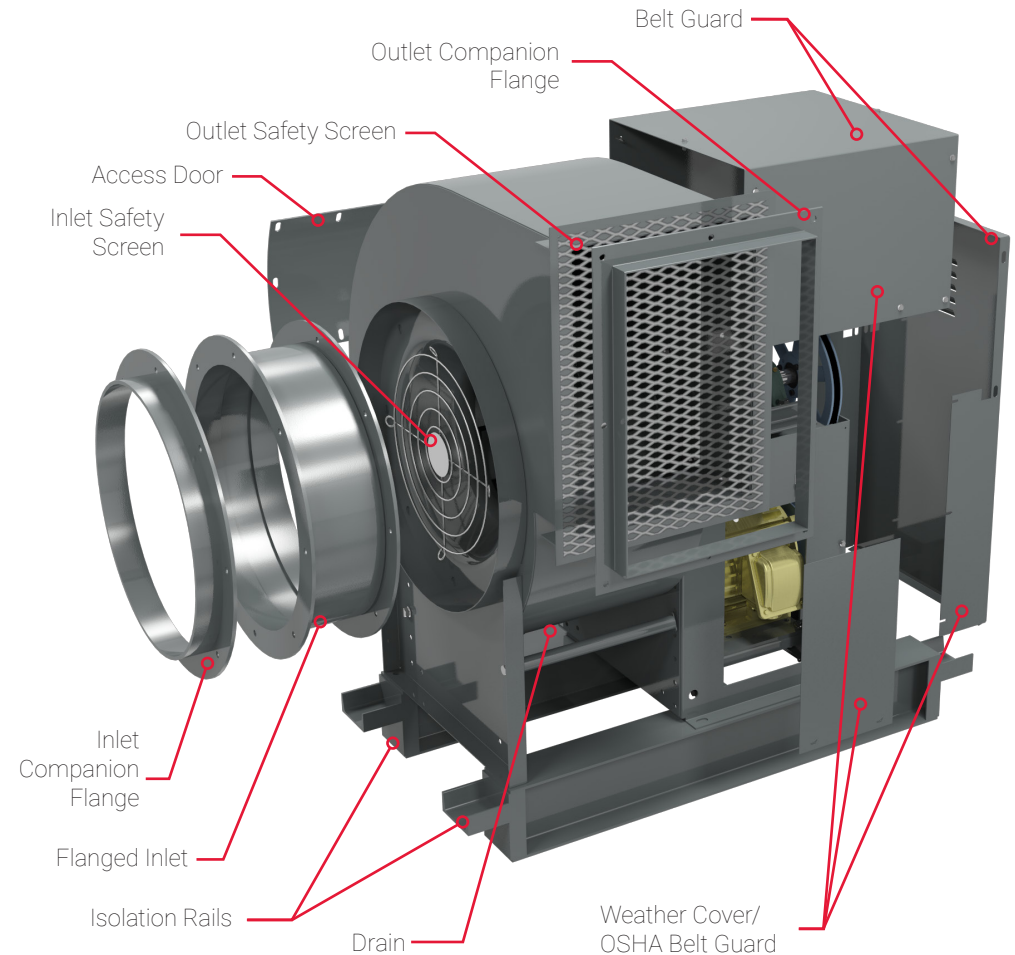

# ACCESSORIES CONTINUED



Beyond the CP Standard Construction Features, Cook offers accessories to fit your custom air-movement requirements and/or preferences.

## BELT TENSIONER

- ▶ Maintains constant drive belt tension
- ▶ Reduces maintenance costs
- ▶ Increases belt life

## SHAFT COOLER

- ▶ Dissipates heat and prevents excessive bearing temperatures
- ▶ Required for air temperature above 300°F

## SHAFT SEAL

- ▶ Reduces air leakage around fan shaft in high pressure applications
- ▶ Constructed of aluminum and aramid fiber/NBD gasket material

## RUB RING

- ▶ Prevents the shaft and wheel from contacting the housing of the CP
- ▶ Constructed of aluminum

## EXTENDED LUBE LINES

- ▶ Quick and convenient way to safely lubricate the bearings while the fan is operating

## PIEZOMETRIC RING

- ▶ Installed in the inlet of a fan
- ▶ Differential pressure and a flow coefficient allows the fan airflow to be calculated by reading the pressure across the inlet
- ▶ **Works with Cook Flow Monitor.**

## PUNCHED INLET/OUTLET FLANGE

- ▶ Available when a flanged duct connection is desired
- ▶ Pre punched with an array of holes at the factory
- ▶ **Also available in NFPA 96 specifications**

## WEATHER COVER DOOR

- ▶ Completely enclose the motor, shaft and drive components
- ▶ Hinged steel door with latches allows access to the drives and motor without removing the weather cover

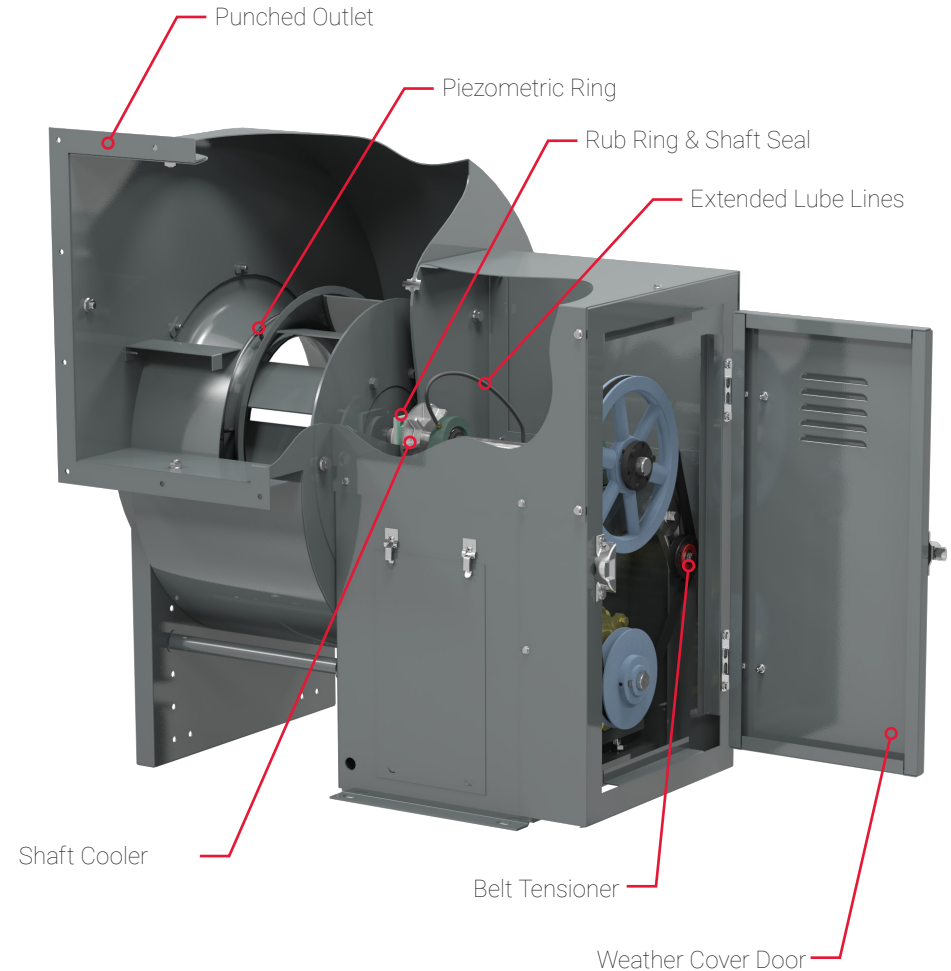

# ACCESSORIES CONTINUED



Beyond the CP Standard Construction Features, Cook offers accessories to fit your custom air-movement requirements and/or preferences.

## ACCESSORIES NOT SHOWN

### DISCHARGE SHUTTER

- ▶ Aluminum or galvanized
- ▶ Gravity or motorized
- ▶ Standard duty shutters operate with velocities up to 2000 FPM
- ▶ Heavy duty shutters for velocities of 2000-3000 FPM

### ISOLATION BASE

- ▶ Heavy duty structural channel
- ▶ Optional height saving brackets are available
- ▶ *See Vibration Isolation brochure for details*

### MOTOR HEAT SHIELD

- ▶ Dissipate heat away from the fan motor

### HIGH TEMPERATURE GREASE

- ▶ High temperatures can break down grease. In these cases, a high temperature grease is provided with the bearings

### STACK EXTENSION

- ▶ Increases discharge height to prevent recirculation of contaminated air
- ▶ See page 14 for details

### 304 STAINLESS STEEL

- ▶ When corrosion resistance is important
- ▶ Both chromium and nickel, key components in resisting oxidation
- ▶ *(CPS/CPS-A only)*

### EXTENDED LIFE BEARINGS

- ▶ Extended life bearings provide up to L10 life in excess of 200,000 hours

### INLET VANE DAMPER (IVD)

- ▶ External IVD provides precise air volume control while maintaining efficiency and stable operation at reduced fan load

### FLEX DUCT CONNECTION

- ▶ Flexible connection between the fan and the attached ductwork
- ▶ Reinforced neoprene fabric and aluminum bands
- ▶ *NOT to be used for restaurant exhaust or smoke control units or temperatures in excess of 250°F*

### CURB CAP AND INLET BOX

- ▶ Provide additional access for wheel and duct work cleaning
- ▶ Less than 1% of impact on performance

### STAINLESS STEEL SHAFT

- ▶ When additional corrosion resistance is desired
- ▶ Type 304 SS is used unless specified otherwise
- ▶ *(Standard on CPA, CPA-A)*

### ROOF CURB

- ▶ Roof support structures for fans and ventilators
- ▶ Available for flat, pitched and peaked roofs with or without insulation

### SPLIT PILLOW BLOCK BEARINGS

- ▶ Offer flexibility in sealing and lubrication, higher loads and range of shaft sizes

### ALUMINUM WHEEL

- ▶ In applications where spark resistance or reduced starting torque is necessary
- ▶ NOT to be used in smoke control applications
- ▶ *(Standard on CPA, CPA-A)*

### GREASE TROUGH

- ▶ Designed to accept grease accumulating in the bottom of the fan while separating and releasing accumulated water

### GREASE TERMINATOR 2

- ▶ A grease-capture and containment system
- ▶ Uses the same material that oil companies use to clean catastrophic oil spills
- ▶ Lasts 30 to 45 days and is then replaced

### CONCENTRIC LOCK BEARINGS

- ▶ Provide significantly more holding force on the fan shaft
- ▶ Are advisable when fan speed is modulated using VFD or other device, and when system conditions cause vibration

# ACCESSORY PACKAGE



Cook also offers a high temperature CP accessory package, which configures fan with all modifications necessary to meet operating requirements. This package provides a quick and simplified selection process.

## HIGH TEMP PACKAGE

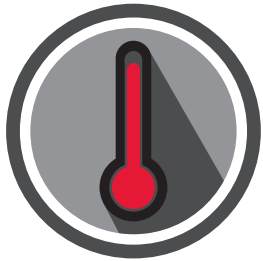

Temperature Range	Construction Requirements
-20°F – 230°F	<ul style="list-style-type: none"><li>▶ Standard construction</li></ul>
231°F – 300°F	<ul style="list-style-type: none"><li>▶ High temperature paint</li><li>▶ RPM limited to 96% of maximum</li></ul>
301°F – 500°F (CPS/CPS-A only)	<ul style="list-style-type: none"><li>▶ Requires steel wheel construction</li><li>▶ High temperature paint</li><li>▶ Shaft cooler</li><li>▶ Motor heat shield</li><li>▶ High temperature weather cover or belt guard (if weather cover or belt guard required)</li><li>▶ RPM limited to 91% of maximum at 500°F</li></ul>



**For more information, contact Loren Cook Company  
at 417-869-6474 or [info@lorencook.com](mailto:info@lorencook.com).**

# INSTALLATION & MOUNTING



Recommended installation and mounting options are shown here. Additional details can be found in the CP Installation, Operation and Maintenance Manual.

## ISOLATION RAILS

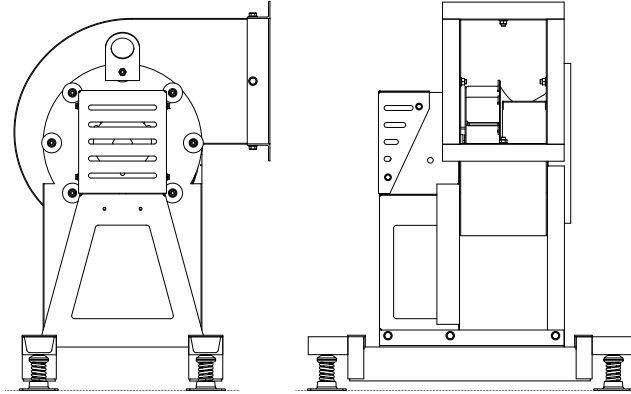

## ISOLATION BASE

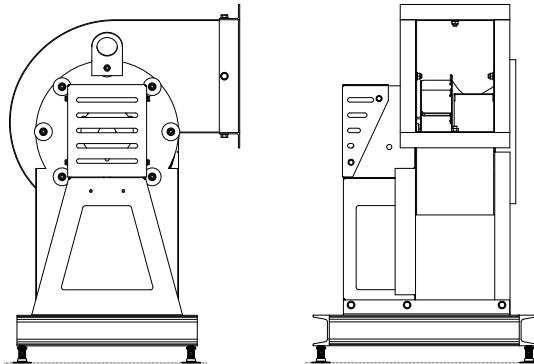

## CP DESIGN BENEFITS



Height saving brackets where vertical space is an issue.



Discharge configurations can be rotated in the field.



Lifting lugs assist in product installation.



For vibration isolation use isolation rails, isolation base or an inertia base. Recommendations can be found in the Vibration Isolation Brochure.

# INSTALLATION & MOUNTING



Cook can provide a pre-engineered stack to extend the CP discharge to 10ft. Preventing contaminated air from reentering the ventilation system.

## STACK EXTENSION

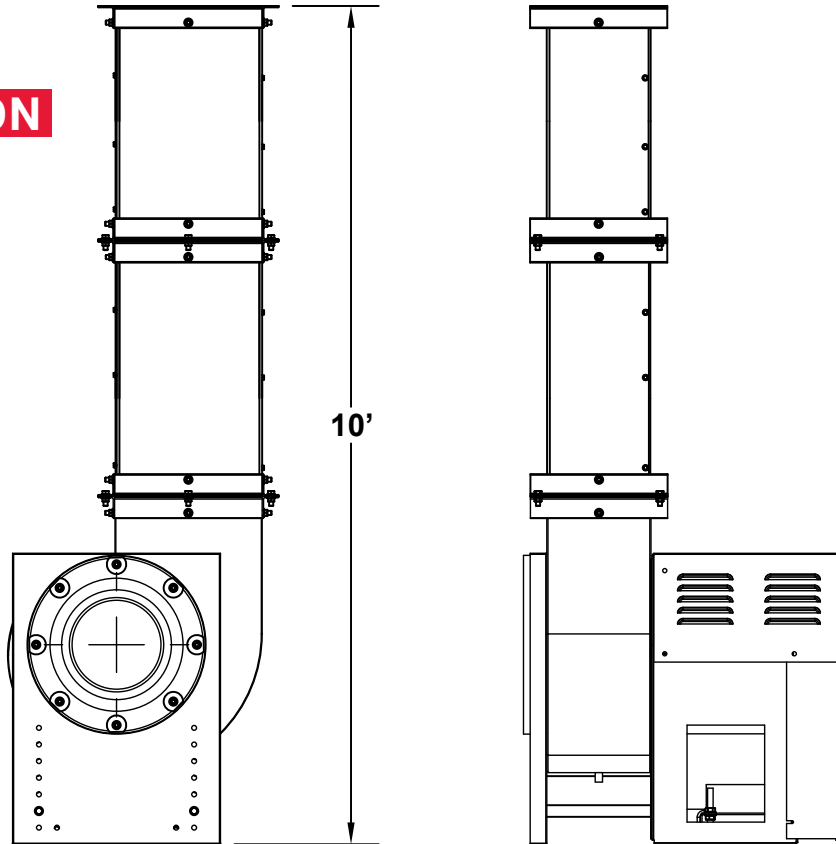

## CP DESIGN BENEFITS



The aluminum stack extension is highly weather resistant.



10 foot discharge height is good up to 125 MPH continuous wind-load without the need of guy-wires.



Lifting lugs assist in product installation.



Available for class 1 & 2 construction on sizes 60-300.



When Stack is provided, a drain is installed in the fan housing.

# INSTALLATION & MOUNTING



Curb cap installation and mounting. Additional detail can be found in the CP Installation, Operation and Maintenance Manual.

## CURB MOUNTED

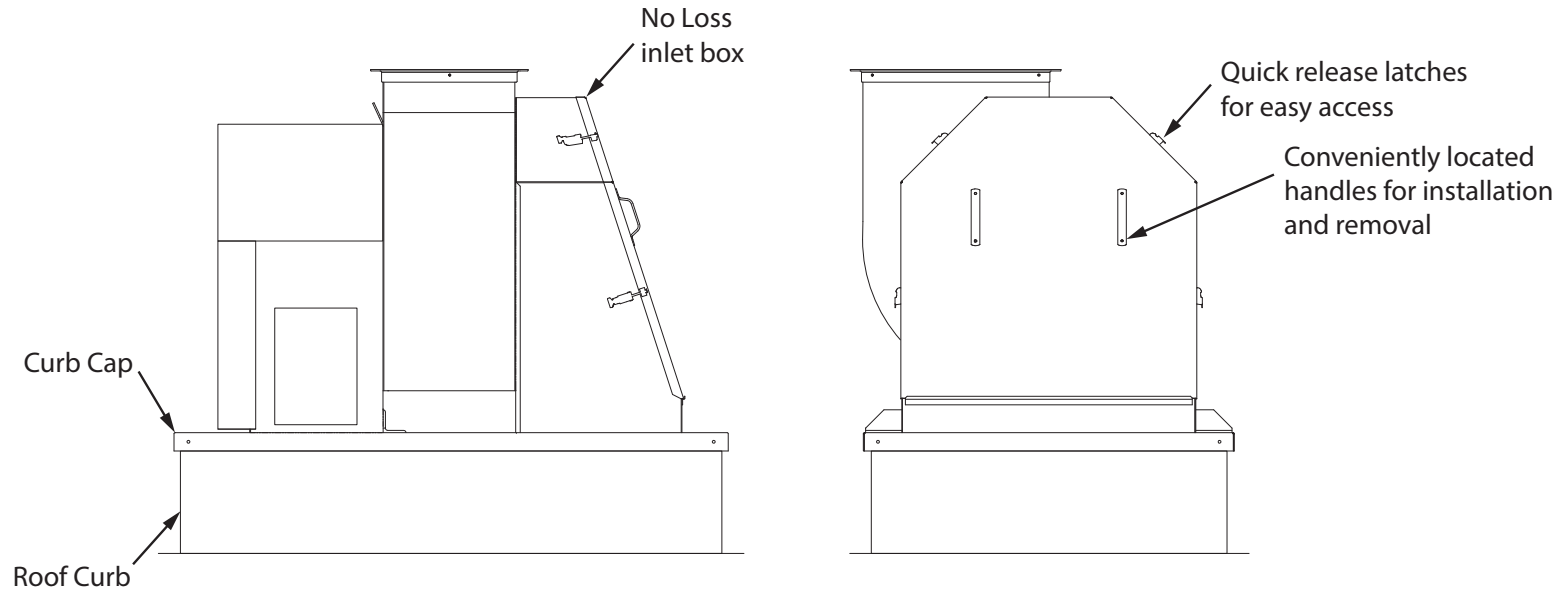

## DESIGN BENEFITS

- ▶ The plenum is designed to have less than 1% impact on performance
- ▶ The plenum provides a removable, gasketed access door with adjustable quick release latches
- ▶ All CP class 1 models are available with integral curb cap and inlet box. (Sizes 60-245) Contact factory for availability of larger sizes or class 2



# INSTALLATION & MOUNTING



For grease collection Cook has you covered with two different options.

## GREASE TERMINATOR 2

The clear, highly durable, plastic container, constructed of recyclable material provides a visual reminder for changing and cleaning needs.

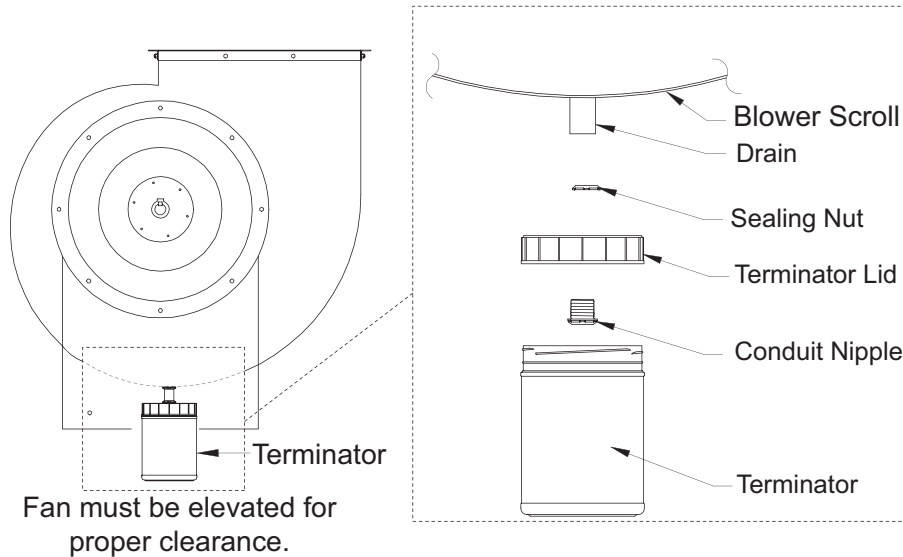

## GREASE TROUGH

The aluminum construction of the Grease Trough pan can be placed in a commercial dishwasher for cleaning. The Grease Trough meets all of the requirements for NFPA 96 installation.

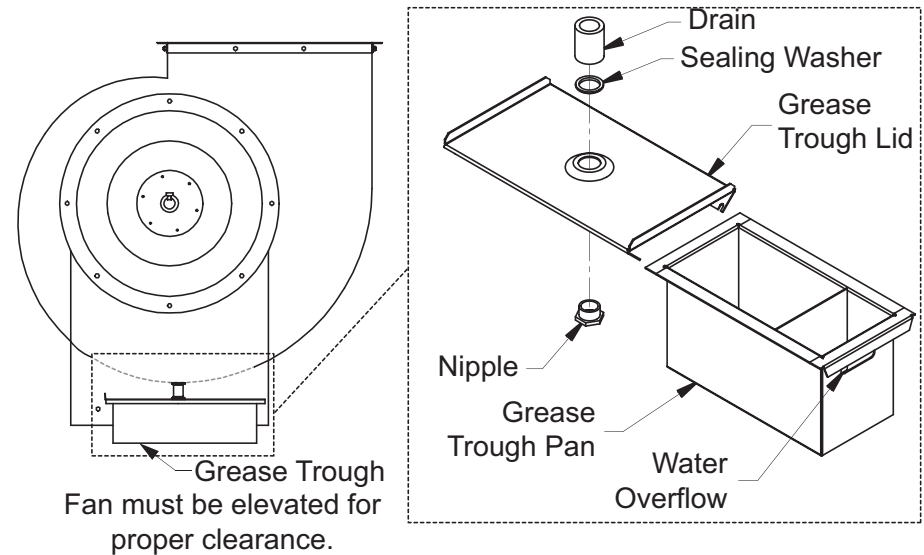

# STANDARD COATING



The CP is available with six coatings. The Lorenized™ coating in gray is standard. Lorenized™ is also available in 12 other colors shown.

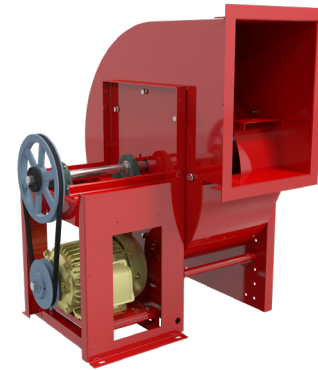

Shown in Lorenized Cook Red

## LORENIZED™ COATING

- ▶ Electrostatically applied, baked polyester powder coating
- ▶ Undergoes a five-stage environmentally friendly pretreatment/wash process before coating
- ▶ Baked and cured at 400°F; final coating thickness of 1.5–2.5 mil
- ▶ Coating is required to exceed 1,000 hour salt spray under ASTM B117 test method
- ▶ Offers strong chemical resistance, durable mechanical performance and tough protection from outdoor elements

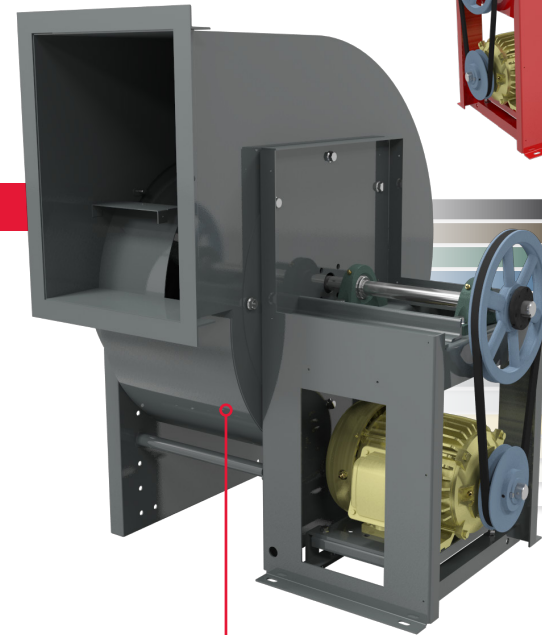

Lorenized™ standard coating on CP

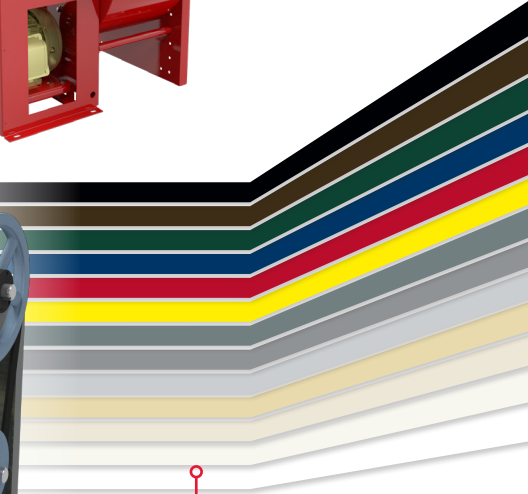

all 13 available Lorenized™ colors

# OPTIONAL COATINGS



Each of the following types of coatings offer unique qualities, benefits and color availability for Loren Cook CPs.

## COOK HIGH TEMP COATING

- ▶ Solvent based, heat resistant liquid coating which exhibits good corrosion resistance and color stability
- ▶ Final coating thickness is 0.8–1.5 mil
- ▶ Withstands service temperatures up to 1,000°F

Available in **BLACK**.

## COOK EPOXY POWDER

- ▶ Electrostatically applied, baked epoxy powder coating
- ▶ Final coating thickness is 2.5–3.5 mil
- ▶ For outdoor applications, an optional UV resistant topcoat is available to prevent coating deterioration

Available in **DARK GRAY**.

## AIR DRY PHENOLIC

### HERESITE® VR-514

- ▶ Conventional spray applied phenolic resin coating
- ▶ Final coating thickness is 2.0–4.0 mil
- ▶ For outdoor applications, an optional UV resistant topcoat (Heresite® UC-5500) is required to prevent deterioration of the coating

Available in **BROWN**.

## COOK EASY-CLEAN POWDER

- ▶ Electrostatically applied, baked modified epoxy silicone powder coating
- ▶ High temperature "non-stick" coating
- ▶ Final coating thickness is 1.0–2.0 mil

Available in **BLACK**.

## COOK PHENOLIC EPOXY POWDER

- ▶ Electrostatically applied, baked phenolic epoxy powder coating
- ▶ Final coating thickness is 1.5–4.0 mil
- ▶ For outdoor applications, an optional UV resistant topcoat is required to prevent coating deterioration

Available in **LIGHT GRAY** and **BROWN**.



**See our Coatings Brochure for more information.**

# CP CERTIFICATIONS



Cook uses third party verification agencies for certification, qualification and listing of fan performance.

\*Available with curb cap and inlet box

†Sizes 60 - 150

## AMCA FEI SOUND AND AIR SEISMIC

### AMCA Certified Ratings Seal

Loren Cook products that bear the AMCA Certified Ratings Seal are licensed by AMCA International. These products meet the AMCA Standard and are within the product scope of AMCA International.



All Models

### Seismically Qualified

The below CP models have been shake table tested to exceed spectral response accelerations covering the most severe seismic conditions found within the United States. For more information, see Seismic Certification Flier.



CPV | CPV-EC | CPV-VF<sup>†</sup>

CPS-A | CPS

» For more information, see Seismic Flier.

## UL 705 LISTED HIGH WIND & HURRICANE

### Power Ventilator

The UL 705 Listing is the standard for electrical safety for permanently connected power ventilators. All CP models are constructed in accordance with UL 705, only when with motors.



Listed

All Models

### High Wind and Hurricane Rated

Through rigorous research and testing, this option is designed to meet three of Miami-Dade County's Testing Application Standards. In addition, all of these products have received approval from the Florida Building Commission.



CPS\* | CPS-A\* | CPFH

CPV\* | CPV-VF<sup>†</sup> | CPV-EC

» For more information, see High Wind & Hurricane Flier.

# CP CERTIFICATIONS CONTINUED



Cook uses third party verification agencies for certification, qualification and listing of fan performance.

## UL SMOKE CONTROL

### Power Ventilator for Smoke Control Systems

The UL Listing “Power Ventilator for Smoke Control Systems” is a test procedure and category initiated by Loren Cook Company and developed in a joint effort with UL in 1990. The products below are UL Smoke Control Listed.

Sizes 60–490

CPS

CPS-A



#### UL Requirements

- ▶ Unit must withstand a specified elevated airstream temperature for a specified duration
- ▶ Unit must be listed under UL 705
- ▶ Requires steel wheel, motor heat shield, and steel housing

» For more information, see [UL Smoke Control Flyer](#).

## UL RESTAURANT EXHAUST LISTED

### Power Ventilator Restaurant Exhaust Appliances

Loren Cook Company products that bear the UL Restaurant Exhaust Listing are designed to exhaust contaminated or grease-laden air. The products shown below are UL Listed to operate continuously at the shown elevated temperatures.

Max. Temp. 300°F

CPV

CPA

CPA-A

Max. Temp. 500°F

CPS

CPS-A



#### UL Requirements

- ▶ Unit must be supplied with drain and access door
- ▶ Outdoor applications must be supplied with a weather cover
- ▶ When airstream temperatures are expected to exceed 180°F, high temperature accessories may be required

» For more information, see [UL Restaurant Exhaust Flyer](#).

# OVERALL DIMENSIONS



The following overall dimensions are for counterclockwise top horizontal discharge units, and are in inches. For more detailed dimensions, see product submittals.

## CPV/CPS/CPA/CPS-A/CPA-A

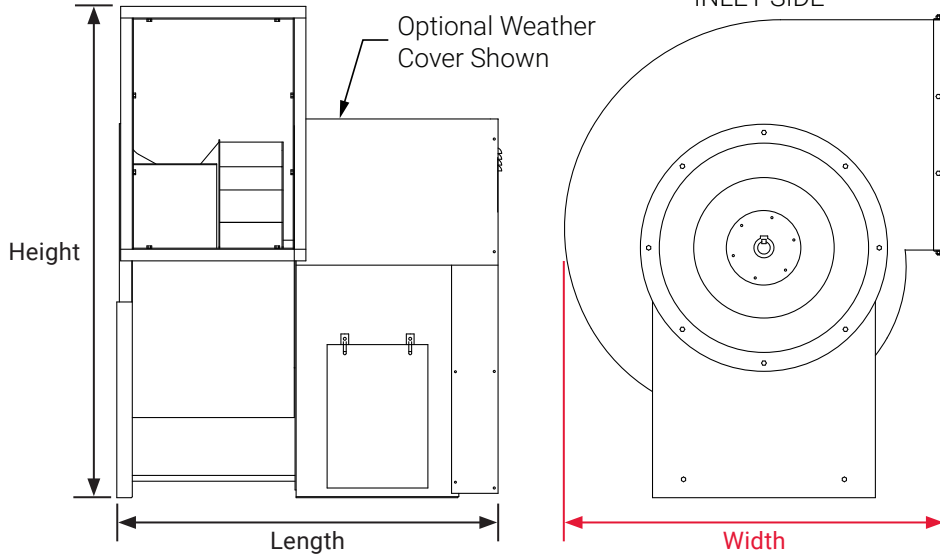

### CLASS 1

Unit Size	Height	Width	Length
60	30 1/2	22 5/16	26 1/2
70	30 1/2	22 5/16	26 1/2
80	30 1/2	22 5/16	26 1/2
100	30 1/2	22 5/16	26 1/2
120	32 5/8	24 7/8	28 1/8
135	34 1/4	26 3/4	31 1/4
150	36 15/16	29 5/8	32 3/8
165	39 15/16	32 1/8	33 9/16
180	43 3/16	34 13/16	34 11/16
195	46 7/16	36 3/8	38 7/8
210	49 13/16	40	41
225	53 1/16	42 1/16	42 1/8
245	58 5/16	45 1/8	44 3/16
270	63 13/16	49 1/8	49 1/16
300	70 3/8	54 1/2	51 1/2
330	76 7/8	59 15/16	53 13/16
365	84 1/2	66 3/16	60 7/16
402	92 5/8	73 1/16	64 5/16
445	101 15/16	80 11/16	71 9/16
490	111 11/16	88 3/4	75

### CLASS 2 (CPV NOT AVAILABLE)

Unit Size	Height	Width	Length
120	36 5/8	24 7/8	36 3/8
135	38 1/4	26 3/4	37 1/2
150	39 7/8	29 5/8	38 5/8
165	43 1/2	32 1/8	44 5/16
180	45 1/8	34 13/16	45 7/16
195	47	36 3/8	46 5/8
210	49 13/16	40	48 3/4
225	53 1/16	42 1/16	50
245	58 5/16	45 1/8	53 5/8
270	63 13/16	49 1/8	56
300	70 3/8	54 1/2	60 3/8
330	76 7/8	59 15/16	62 3/4
365	84 1/2	66 3/16	66 11/16

# OVERALL DIMENSIONS



The following overall dimensions are for counterclockwise top horizontal discharge units, and are in inches. For more detailed dimensions, see product submittals.

## CPF B

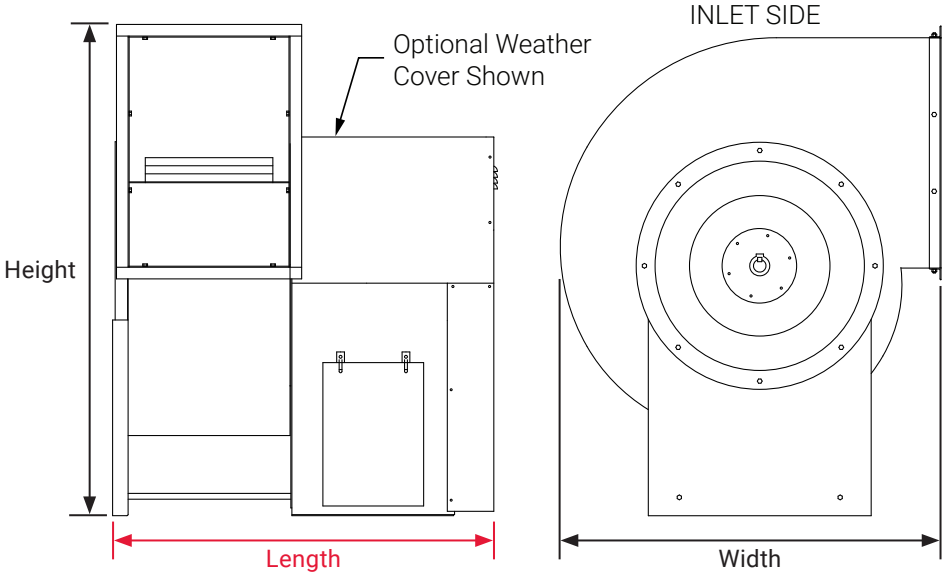

Unit Size	100	120	150	180	220	250	270	300
Height	30 1/2	32 5/8	36 15/16	43 3/16	53 1/16	58 5/16	63 13/16	70 3/8
Length	26 9/16	28 3/8	32 7/16	34 13/16	42 5/16	44 5/16	49 3/16	52 3/16
Width	22 5/16	24 7/8	28 5/8	34 13/16	42 1/16	45 1/8	49 1/8	54 1/2



# OVERALL DIMENSIONS



The following overall dimensions are for counterclockwise top horizontal discharge units, and are in inches. For more detailed dimensions, see product submittals.

## CPFD

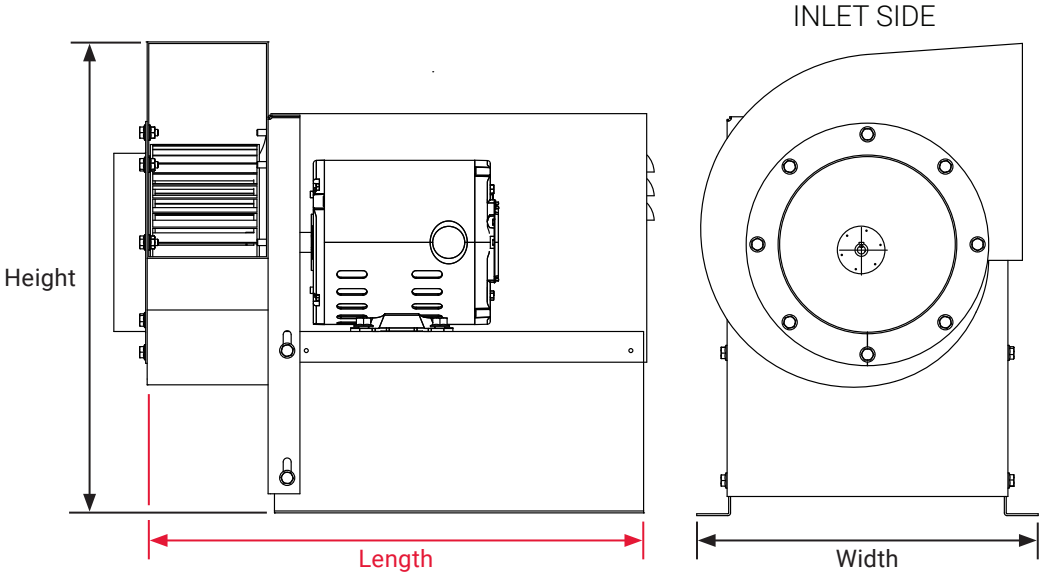

Unit Size	6	7	9	10	12
Height	15 3/4	18 5/8	20 1/2	24 15/16	27
Length	18 1/2	20 1/4	21 3/4	22 1/4	23 3/4
Width	13 1/2	13 1/2	14	15 1/2	17

# OVERALL DIMENSIONS



The following overall dimensions are for counterclockwise top horizontal discharge units, and are in inches. For more detailed dimensions, see product submittals.

## CPV DIRECT DRIVE WITH EC MOTOR

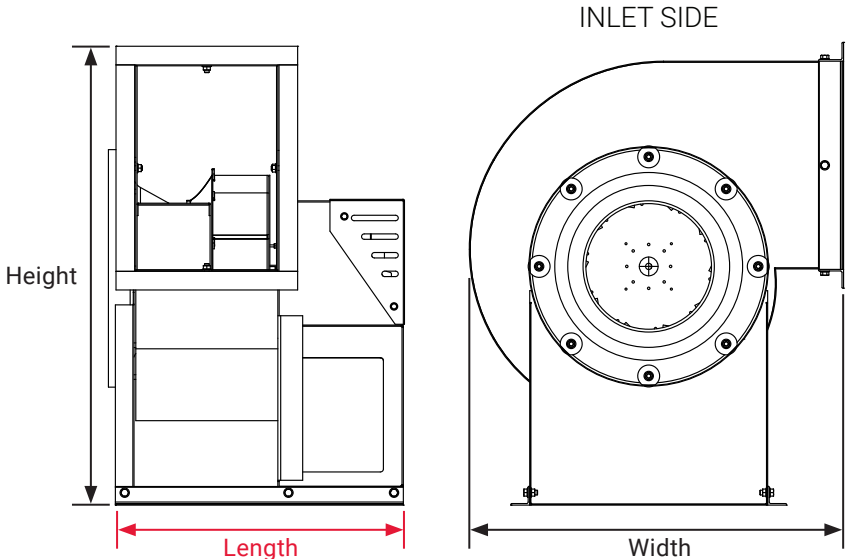

Unit Size	60	70	80	100	120	135	150	165	180	195	210
<b>Height</b>	30 1/2	30 1/2	30 1/2	30 1/2	32 5/8	34 1/4	36 15/16	39 15/16	43 3/16	46 7/16	49 13/16
<b>Length</b>	16 5/16	16 5/16	16 5/16	16 5/16	20 7/16	22 1/16	23 3/16	24 3/8	25 1/2	26 11/16	27 13/16
<b>Width</b>	22 5/16	22 5/16	22 5/16	22 5/16	24 7/8	26 3/4	29 5/8	32 1/8	34 13/16	36 3/8	40

