



MODEL 3334 & 3334-4003 SERIES POWER MEAT SAW
OPERATING AND SERVICE MANUAL
REVISED - SERIAL No.1,000 ON
SQ. BASE #35323 ON
FLAT TOP #35323 ON



3334SS



3334SS-4003

☆ **IMPORTANT NOTICE** ☆

This Manual contains important safety instructions which must be strictly followed when using this equipment.

TABLE OF CONTENTS

	PAGE
NOTICE TO OWNERS AND OPERATORS	1
SAFETY TIPS	2
INSTALLATION	3
WARNING LABELS FOR POWER SAWS	5
OPERATION	6
TO PROCESS PRODUCT	6&7
WALL CHART (PART No. 671)	8
OPERATOR'S NOTES	9
CLEANING	10
MAINTENANCE	11
GENERAL	11
LUBRICATION	12
MOTOR ADJUSTMENT	13
SAW GUIDE BAR AND SAW GUARD	13&14
LONGER SAW GUARD KIT	15&16
BASE DOOR HINGE SYSTEM	17
NEW DESIGN "FLAT TOP" BASE	18
PARTS DIAGRAMS	19-28
MOTOR COVERS	29
PARTS DIAGRAM, LOWER REMOVABLE WHEELS	29-32
SWITCH ASSEMBLIES AND SERVICE PARTS	33&34
WIRING DIAGRAMS	35-41
PARTS LIST/ORDERING	42&43
PARTS ASSEMBLIES LIST/ORDERING	44
STAINLESS STEEL HEAD STRUCTURE HISTORY	44
WEARABLE SAW PARTS LIST	45
WARNING LABEL LOCATIONS ON MACHINE	46&47
OPERATOR'S SIGNATURE	48
LIMITED WARRANTY	49

NOTICE TO OWNERS AND OPERATORS

BIRO's products are designed to process food products safely and efficiently. Unless the operator is properly trained and supervised, however, there is the possibility of a serious injury. It is the responsibility of the owner to assure that this machine is used properly and safely, strictly following the instructions contained in this Manual and any requirements of local law.

No one should use or service this machine without proper training and supervision. All operators should be thoroughly familiar with the procedures contained in this Manual. Even so BIRO cannot anticipate every circumstance or environment in which its products will be used. You, the owner and operator, must remain alert to the hazards posed by the function of this equipment - particularly the SHARP MOVING BAND TYPE SAW BLADE. No one under eighteen (18) years of age should operate this equipment. If you are uncertain about a particular task, ask your supervisor.

This Manual contains a number of safe practices in the SAFETY TIP section. Additional warnings are placed throughout the Manual. Warnings related to your personal safety are indicated by:



OR



Warnings related to possible damage are indicated by:



BIRO also has provided a wall chart to be posted near the equipment. If any warning label, wall chart, or Manual becomes misplaced, damaged, or illegible, please contact your nearest Distributor or BIRO directly for a replacement.

Remember, however, this Manual or the warning labels do not replace the need to be alert and to use common sense when using this equipment.

This Manual applies to machines with serial number 1,000 and higher.

- NOTE -

**A copy of this manual is included with each
MODEL 3334 & 3334-4003 POWER MEAT SAW.**

**The descriptions and illustrations contained in this manual are not binding.
The manufacturer reserves the right to introduce any modification without
updating the manual.**

SAFETY TIPS



SHARP MOVING BAND TYPE SAW BLADE TO AVOID SERIOUS PERSONAL INJURY

***NEVER** Touch This Machine Without Training and Authorization By Your Supervisor.*

***ALWAYS** Read Operation and Parts Manual **BEFORE** Operating, Cleaning or Servicing.*

***ALWAYS** Keep Hands Clear of Sharp Band Type Saw Blade and Other Moving Parts.*

***ONLY** Use a Qualified Electrician to Install According to Local Building Codes: Machines **MUST** Be Properly Grounded.*

***ONLY** Install on Level, Non-Skid Surface in a Clean, Well-Lighted Area Away From Children and Visitors.*

***DO NOT** Attempt to Operate This Machine Until it has Been Inspected and Demonstrated by the Seller - Recognized **BIRO** Representative.*

***DO NOT** Alter or Modify This Machine in any Way From its Original Form. This Machine in its Original Form Meets the Intent of O.S.H.A. Applicable Standards.*

***NEVER** Operate with Saw Guard on Saw Guide Bar in the Raised Position or the Saw Guard Removed from the Saw Guide Bar.*

***ALWAYS** Adjust the Saw Guide Bar with Saw Guard to Within ½" of Product to be Cut.*

***ALWAYS** Use Supplied Safety End Cut Pusher Plate for Smaller Products or The Last Cuts of Products.*

***DO NOT** Use This Machine for Non-Food Products.*

***DO NOT** Use This Machine to Cut Pigs Feet.*

***DO NOT** Wear Gloves While Operating.*

***ALWAYS** Turn Off, Unplug From Power Source and Perform Lockout/Tagout Procedure to This Machine **BEFORE** Removing Shrouds, Removable Guards, Covers, Doors, Fences or Panels for Cleaning, Servicing or Any Other Reason.*

***NEVER** Leave Machine Unattended While the Saw is Running.*

***PROMPTLY REPLACE** Any Worn or Illegible Warning Labels.*

***USE ONLY BIRO** Parts and Accessories Properly Installed.*

INSTALLATION



TO AVOID SERIOUS PERSONAL INJURY PROPERLY INSTALL EQUIPMENT IN ADEQUATE WORK AREA

ALWAYS Read Operating and Service Manual **BEFORE** Operating, Servicing, or Cleaning.

ALWAYS Use Qualified Technician and Electrician for Installation.

ONLY Install on a Level, Non-Skid Surface in a Clean, Well-Lighted Work area Away From Children and Visitors.

DO NOT Attempt to Operate This Machine Until it has Been Inspected and Demonstrated by the Seller - Recognized **BIRO** Representative.

DO NOT Alter or Modify This Machine in Any Way from its Original Form. This Machine in its Original Form Meets the Intent of O.S.H.A Applicable Standards.

NEVER Operate with Saw Guard Bar with Saw Guard in the Raised Position or the Saw Guard Removed from the Saw Guide Bar.

ALWAYS Turn Off, Unplug From Power Source and Perform Lockout/Tagout Procedure to This Machine **BEFORE** Removing Shrouds, Removable Guards, Covers, Doors, Fences or Panels for Cleaning, Servicing or Any Other Reason.

NEVER Operate Without all Warning Labels Attached and Wall Chart Posted.

NEVER Leave Machine Unattended While the Saw is Running.

USE ONLY BIRO Parts and Accessories Properly Installed.

1. Read this Manual thoroughly before installation and operation. **Do not** proceed with installation and operation if you have any questions or do not understand anything in this Manual. Contact your local Distributor, or BIRO first.

2. Install machine on a level, solid, non-skid surface in a well-lighted work area away from children and visitors.



ALWAYS LEVEL MACHINE BEFORE USING

3. After installing machine in operational area, it is imperative that the four adjusting legs be adjusted to level the machine.

4. To assemble the meat gauge plate (Part No. AS16275) to the machine, loosen the lock knob (Part No. 272-7-1) on the right side of meat gauge bracket. Raise the meat gauge gear rack (Part No. S16272) and slip the meat gauge plate over the gear rack. Lower the gear rack to its original position, tighten lock knob. Keep gear rack well oiled with a food grade oil to ensure free movement.

5. The head structure (Part No. 16005) comes detached from the base. Slip the head into the slide gibs (Part No. 260) located on the back of the base structure. Make sure the slide gibs are oiled or greased to ensure free vertical movement of the head structure.

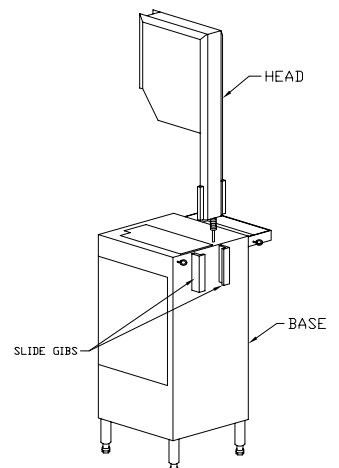

6. Place removable finger lift with saw guard assembly (Part No. A211) on the saw guide bar (Part No. 116-22) and fasten in place with finger lift fastener knob (Part No. 211A-291Q).



SHARP SAW BLADE. HANDLE WITH EXTREME CAUTION

7. Placing blade on cutter: Hang upper wheel assembly (Part No. A16003U335-6) on the hinge bracket (Part No. 71-1). Lift the nylon filler (Part No. 177). Hang blade on the upper wheel and hold with right hand. With left hand force the back of the blade between the front blade cleaners (Part No. 131), located below the nylon filler and insert the back of the blade in the upper saw guide (Part No. 602B). The blade has already dropped over the lower wheel. With right hand force the back of the blade between the rear blade cleaners (Part No. 131). The blade is now ready to be tightened. Press down on the ratchet arm (Part No. 10-1) located at the rear of the base structure. Turn the upper wheel slowly by hand to ensure proper tracking of the saw blade on the wheels. Tighten to proper tension. When the tension gauge (Part No. 16197) located at the bottom rear of the head becomes tight laterally, the blade is at proper tension.
8. The side platter bracket (Part No. S12214B) is packed loose in the machine and must be installed on the left side of the base structure with the supplied hardware and checked for proper adjustment. Stationary platter must be flat.
9. The stationary platter (Part No. A16163-1) is placed on top of the base structure and held in place by two push-pull hold down catches (Part No. 16212), located on the base structure.
10. The sliding meat carriage assembly (Part No. A16155) is installed by turning the movable stop assembly (Part No. A16200) clockwise. After the carriage assembly is in the channel for operation, turn the movable stop counterclockwise to lock.
11. Post SAFETY TIPS wall chart within easy view of operator. Keep Manual available to operator.
12. Machine MUST be properly grounded. Use qualified electrician to install according to building codes.

WIRING MOTOR

1. Interchange of motor current is made in motor outlet box. Leads are properly marked. Changing instructions are on motor plate or inside junction box cover.
2. All saws are wired 220 volts unless otherwise specified. Be sure motor specifications (voltage, cycle, phase) match power supply line. Be sure line voltage is up to specification.
3. Connect leads to machine in a manner that will be approved by local electrical inspectors.
4. We recommend no less than No. 12 wire. If the leads are too light, machine may not have sufficient cutting power and/or speed.
5. The drive belt is packed loose in machine to prevent deformation, and must be installed on pulleys at time of wiring motor.
6. The BIRO Manufacturing Company is not responsible for permanent wiring, connection or installations.



NOTE TO OWNER AND ELECTRICIAN: IF THIS MACHINE IS NOT CORD AND PLUG CONNECTED TO THE ELECTRICAL SUPPLY SOURCE, THEN IT SHOULD BE EQUIPPED WITH, OR CONNECTED TO, A LOCKABLE, MANUALLY OPERATED DISCONNECT SWITCH (1010.147 OSHA).



KEEP HANDS CLEAR OF SHARP MOVING BAND TYPE SAW BLADE

13. Make sure saw guide bar with saw guard is in its lowest position. Close head and base doors.
14. Push start button and check for proper phasing of motor. Blade should be travelling down through the guide.
15. Watch for proper tracking of blade. Back of blade should be centered in hole in saw guide in stationary bar (Part No. S119A). Push stop button to stop machine.
16. Check placement of all warning labels, wall chart and Manual. Machine is ready for trained operators to process product.
17. Contact your local Distributor or BIRO directly if you have any questions or problems with the installation or operation of this machine.

**WARNING LABELS
FOR BIRO POWER SAWS
SEE PAGE 46 AND 47 FOR LOCATIONS ON MACHINE**

Item No. 653PC-E

Item No. 653PC-SP

Item No. 16716

Item No. 710

Item No. 708

OPERATION



SHARP MOVING BAND TYPE SAW BLADE

TO AVOID SERIOUS PERSONAL INJURY

ONLY Properly Trained Personnel Should Use This Equipment.

ALWAYS Keep Hands Clear of Band Type Saw Blade and Other Moving Parts.

NEVER Operate with Saw Guard on Saw Guide Bar in the Raised Position or the Saw Guard Removed from the Saw Guide Bar.

ALWAYS Adjust the Saw Guide Bar with Saw Guard to Within ½" of Product to be Cut.

ALWAYS Use Safety End Cut Pusher Plate for Smaller Products or The Last Cuts of Product.

DO NOT Wear Gloves While Operating.

DO NOT Tamper With, Bypass, Alter, or Modify this Equipment in Any Way or Form.

ALWAYS Turn Off, Unplug from Power Source and Perform Lockout/Tag Out Procedures Before Cleaning, Servicing or When Not in Use.

NEVER Leave Machine Unattended While the Saw is Running.

NEVER Operate Without All Warning Labels Properly Affixed to Machine.

A. TO PROCESS PRODUCT

1. Before starting power saw, adjust saw guide bar with saw guard to within ½" (13 mm) of product to be cut.

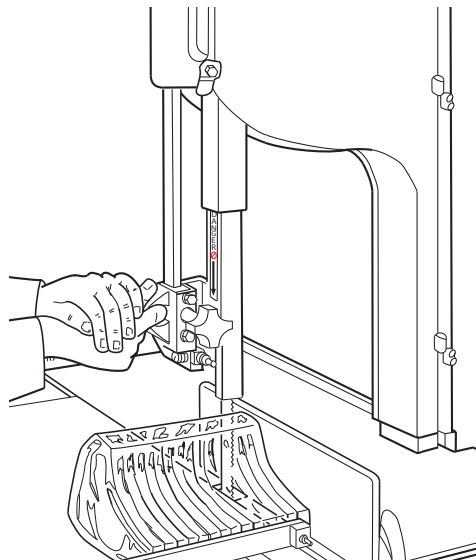

DO NOT WEAR GLOVES WHILE OPERATING

2. Make sure all doors are closed and locked.
3. Adjust meat gauge plate forward to desired thickness of cut. "A"
4. Push start button and watch blade for proper tracking.
5. Standing in front of the power saw, place product on the meat carriage. Pay attention to position of your hands. Keep hands clear of moving band type saw blade. Leaning lightly against the scalloped front edge of meat carriage, hold the product firmly in right hand with product face flush against the meat gauge plate. Move the meat carriage from right to left at a steady rate until fully past the saw blade. Use left hand to remove and stack cut product, **NEVER REACH IN FRONT OF BAND TYPE SAW BLADE**. On the return stroke, pull the product slightly toward you, away from the saw blade.



NEVER REACH OR GRAB FOR PRODUCT IN FRONT OF MOVING BAND TYPE SAW BLADE

6. ALWAYS use the Safety End Cut Pusher Plate (Part No. 256P) for smaller products or the last cuts of product. "C" The pusher plate is supplied as standard on all BIRO power saws.

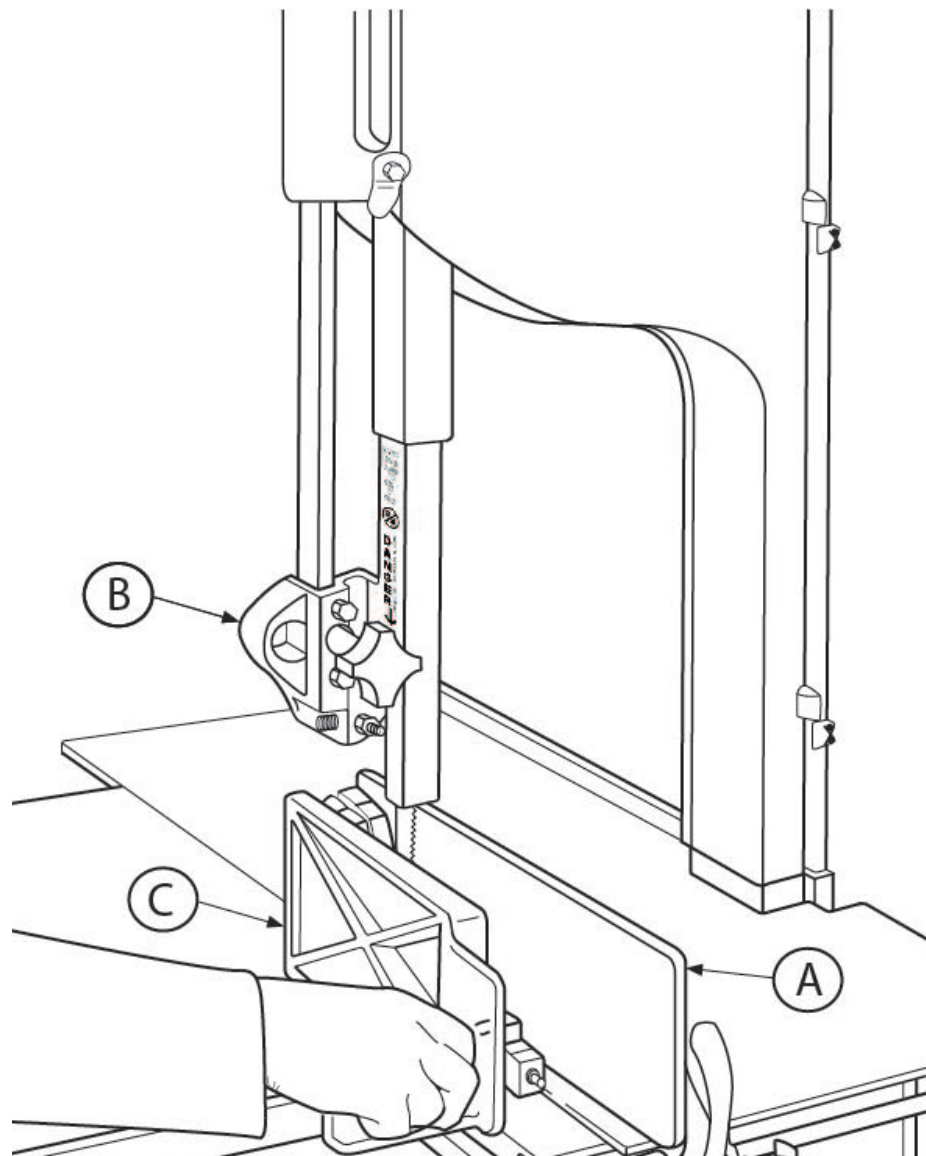

7. When finished cutting, push stop button. Perform lockout/tagout procedure.

ITEM NUMBER 671

WALL CHART “BAND SAW SAFETY GUIDELINES”

ATTACH TO WALL IN VICINITY OF MACHINE IN EASY VIEW OF OPERATOR.



WARNING

ONLY TRAINED OPERATORS SHOULD USE THIS EQUIPMENT

**This Saw Contains A Sharp Blade.
To Avoid Serious Injury:**

1. Inspect Before Operating:

- Gauge Plate **(A)** and Blade Guard Are Secure.
- All Warning Labels And Guards Are In Place.
- The Guide Bar **(B)** Is Adjusted to 1/2 Inch Above The Product To Be Cut

2. While Cutting:

- Keep Hands And Fingers Away From Blade.
- Keep Product Securely Against Gauge Plate **(A)**.
- Use End Cut Pusher Plate **(C)** When Making Final Cuts. Item No. 256P.

3. Before Cleaning:

- Turn Off Power And Follow Lockout / Tagout Procedure.
- Remove Saw Blade.
- Use Extra Care When Handling The Saw Blade.

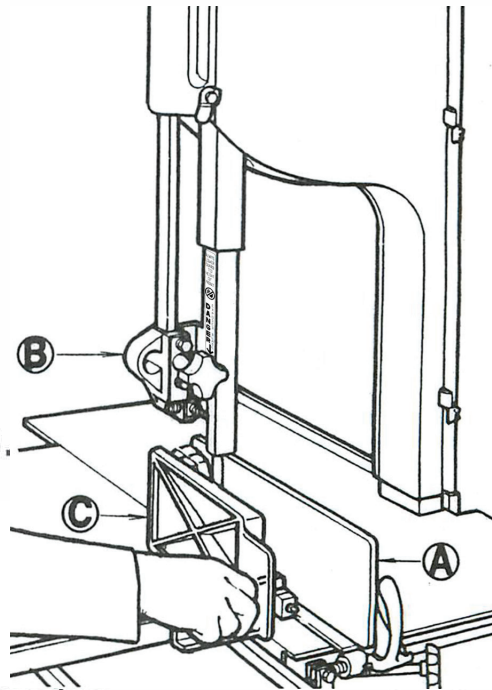

USE YOUR MEAT SAW SAFELY!

SEE PARTS AND SERVICE MANUAL SUPPLIED WITH MACHINE FOR ADDITIONAL SAFETY INFORMATION.

#671

OPERATOR'S NOTES

CLEANING



SHARP MOVING BAND TYPE SAW BLADE TO AVOID SERIOUS PERSONAL INJURY

ALWAYS Turn Off, Unplug From Power Source and Perform Lockout/Tagout Procedure to This Machine **BEFORE** Cleaning or Servicing.

ONLY Use Recommended Cleaning Equipment, Materials and Procedures.

NEVER Spray Water or Other Liquid Substances Directly at Motor, Power Switch or any Other Electrical Components.

ALWAYS Thoroughly Clean Equipment at Least Daily.

CLEANING THE BIRO POWER SAW:

Disconnect electrical power to the machine before cleaning. Parts to be removed have been made accessible and can be removed without tools. Notice in the drawing below that all parts are numbered. Each part should be removed for cleaning in the numbered sequence shown. To ensure cleaner cuts, keep the parts on the cleaning system in good condition. Parts on the cleaning system which should be checked weekly, and changed as required are as follows: Wheel Cleaners (Part No. 179), Saw Cleaners (Part No. 131), Saw Guide in Stationary Bar (Part No. S119A), Upper Saw Guide (Part No. 602B), Lower Blade Back-Up Guide (Part No. 605), and Nylon Filler (Part No. 177).

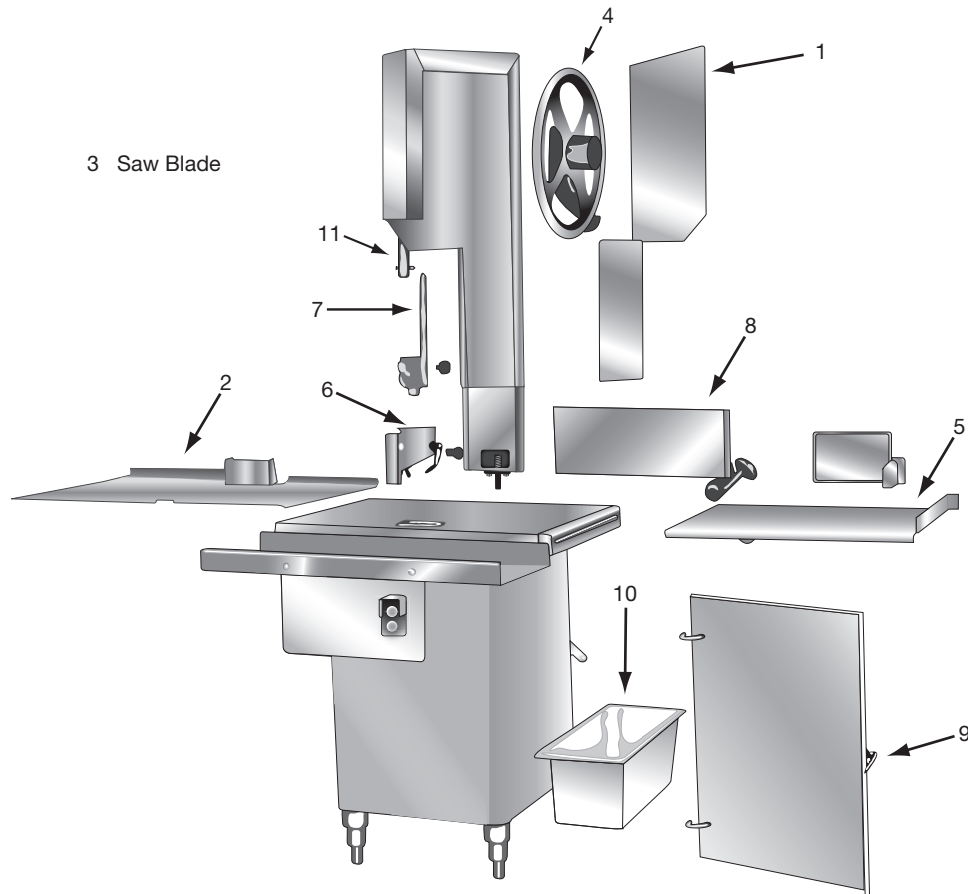

MAINTENANCE



WARNING



SHARP MOVING BAND TYPE SAW BLADE TO AVOID SERIOUS PERSONAL INJURY

ALWAYS Turn Off, Unplug From Power Source and Perform Lockout/Tag Out Procedure to This Machine **BEFORE** Cleaning or Servicing.

NEVER Touch This Machine Without Training and Authorization By Your Supervisor.

ALWAYS Keep Hands Clear of Band Type Saw Blade and Other Moving Parts.

NEVER Bypass, Alter, or Modify This Equipment in Any Way From It's Original Condition.

PROMPTLY REPLACE Any Worn or Illegible Warning Labels.

USE ONLY GENUINE BIRO Parts and Accessories Properly Installed.

A. GENERAL

1. Machine should be generally inspected every time it is cleaned (at least daily) to ensure that it is in good condition and has not been damaged or tampered with.
 - a. SAW WHEELS: Clean outer diameter grooves daily. Check for cracks, gouges or wear on the flange and grooves.



CAUTION

DO NOT IMMERSE UPPER WHEEL ASSEMBLY IN WATER

- b. WHEEL CLEANER ASSEMBLIES: Check condition of fiber cleaner, change every four (4) weeks.
- c. REMOVABLE FINGER LIFT ASSEMBLY: Check condition of saw guard, make sure mounting bolts are tight and the "DANGER EXPOSED BLADE" decal is affixed and legible. Check condition of upper saw guide (Part No. 602B), replace every six (6) months. Check adjustment of upper saw guide. Should be 1/32" between back of blade and saw guide carbide.



**NEVER USE THIS MACHINE WITHOUT PROPERLY INSTALLED
AND FUNCTIONING SAW GUIDE BAR AND SAW GUARD**

- d. SAW GUIDE BAR: Check condition of bar for coating peeling and wear, replace as necessary. Check saw guide bar spring for proper tension. The spring should hold the bar in any desired position in its travel. Replace saw guide bar spring (Part No. 193) as necessary using instructions below.

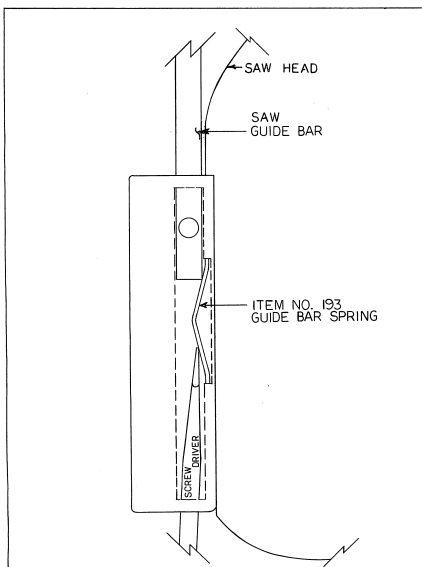

1. Remove the finger lift fastener knob and the finger lift assembly.
2. Remove the finger lift fastener stud.
3. Push the saw guide bar up and out of the top of the head structure.
4. Remove the saw guide bar spring.
5. Clean and lubricate the babbitt pocket area (the square indented area that seats the saw guide bar spring).
6. Lower the new saw guide bar spring through the top of the babbitt pocket area and guide the spring into position with a standard screwdriver.
(NOTE: drawing)
7. While holding the saw guide bar spring in position, re-enter the saw guide bar from the top compressing the saw guide bar spring slightly until the saw guide bar slides past the spring.
8. Replace the finger lift fastener stud, the finger lift assembly and the finger lift fastener knob.
9. Test by making several adjustments.

- e. **STATIONARY BAR ASSEMBLY:** Check condition of nylon filler (Part No. 177), change every four (4) weeks. Check condition of saw guide (Part No. S119A), check tracking of blade through guide, back of blade should be centered in hole, replace every six (6) months. Check condition of lower blade back-up guide (Part No. S608). Check condition of back-up guide, should have 1/32" gap between back of blade and saw guide carbide. Replace every six (6) months.
- f. **SAW CLEANERS:** Check condition of blade cleaners, replace every four (4) weeks.
- g. **RATCHET ASSEMBLY:** Check for smooth operation through full range of travel. Check condition of trigger spring, replace as necessary.
- h. **SLIDE GIBS:** Check that head structure moves freely up and down. Check for side to side and front to rear tolerance, adjust as required. Grease every four (4) weeks.
- i. **MEAT GAUGE ASSEMBLY:** Check free movement of meat gauge plate on gear rack. Gear rack to be kept lubricated at all times with light food grade oil. Check operation of release handle. Check that worm gear engages properly with gear rack. Check tension of release handle spring, replace as necessary.
- j. **MEAT CARRIAGE ASSEMBLY:** Check free movement through full range of travel. Check side to side for excessive clearance, adjust as necessary. Check condition of and grease bearings, replace as necessary. Check condition of thumb guard, replace as necessary.
- k. **SAFETY ITEMS:** Safety end cut pusher plate is with machine and accessible. All warning labels are present, properly affixed and legible. Model and Serial Number plate is properly affixed and legible. Wall poster within operators view from machine. Manual accessible to operator.

**USE BIRO No. 374 GREASE FOR RE-GREASING
SEE INSTRUCTIONS BELOW**

B. LUBRICATION:

1. **UPPER WHEEL BEARINGS:** Grease every four (4) months. Change grease every twelve (12) months. (See instructions at right.)
2. **LOWER BEARING HOUSING:** Grease every four (4) months. Change grease every twelve (12) months.
3. **SLIDE GIBS:** Grease every four (4) weeks.
4. **MEAT CARRIAGE BEARINGS:** Grease every four (4) weeks.
5. **SAW GUIDE BAR:** Oil daily with food machine oil.
6. **MEAT GAUGE GEAR RACK:** Oil daily with food machine oil.

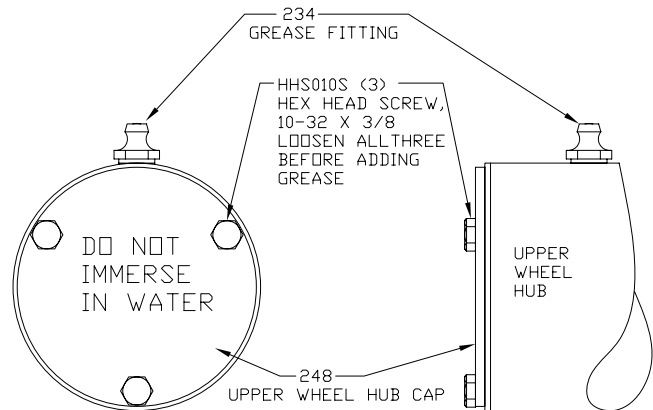

When lubricating the upper wheel bearing it is important that the three hex head screws securing the upper wheel hub cap be loosened slightly before attempting to pump grease into the grease fitting. Loosening the screws allows for an escape of old broken down grease and air from the bearing cavity. Failure to loosen the screws before greasing the upper bearings can cause the upper shaft seal to be dislodged from the upper wheel allowing grease to escape and moisture to get into the cavity. When finished greasing the bearings, retighten the three screws. Take care to also clean off any grease that was pushed out of the cavity during greasing.

7. **MOTOR BEARINGS:** Bearing grease will lose its lubricating ability over time, not suddenly. The lubricating ability of a grease (over time) depends primarily on the type of grease, the size of the bearing, the speed at which the bearing operates and the severity of the operating conditions. Good results can be obtained if the following recommendations are used in your maintenance program.

A high grade ball or roller bearing grease should be used. Recommended grease for standard service conditions is Polyrex EM (Exxon Mobil).

Equivalent and compatible greases include: Texaco Polystar, Rykon Premium #2, Pennzoil Pen 2 Lube, and Chevron SRI.

Recommended lubrication intervals is every 12 months with the equivalent of two (2) teaspoons of grease.

If motor does not have zerk fittings, the motor bearings are sealed for life.

C. MOTOR ADJUSTMENT:

Starting with Serial Number 27958 three (3) phase Model 3334's will no longer be equipped with an adjustable motor base plate, Part No. 16015-10 and 16015-11. The motor will be bolted to the bottom of the base structure and V-belt tension adjusted utilizing shims.

This change has evolved as a result of the market demand for higher blade speeds. The revised mounting procedure will insure a more rigid motor installation creating positive belt alignment and minimizing machine vibration.

The base bottom has been redesigned to accept the frame sizes of the current 3 phase motors. Units prior to Serial Number 27958 can be retrofitted by ordering Part No. 16015-12 motor base plate and template (flat), and 36 pieces Part No. 324A motor shims.

ADJUSTMENTS

1. For tightening motor V-belt on *rigid* base plate, remove appropriate quantity of shims (Part No. 324A) under the motor until the desired total flex of the V-belt is approximately $\frac{1}{2}$ ".

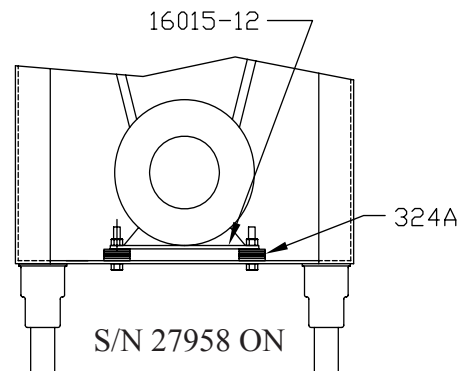

1. For tightening motor V-belt on *floating* adjustable motor mounting plates (Part No. 16015-10 or 16015-11), loosen the upper wing nuts (Part No. 16015-3). Then loosen the bottom wing nuts (Part No. 16015-3) which are located under the mounting plate. This enables the motor mounting plate to drop to the desired belt tension. Re-tighten the upper wing nuts evenly so that the motor stays horizontal. Do not tighten belt to extremes. This will cause undue pressure on and premature failure of the motor bearings.

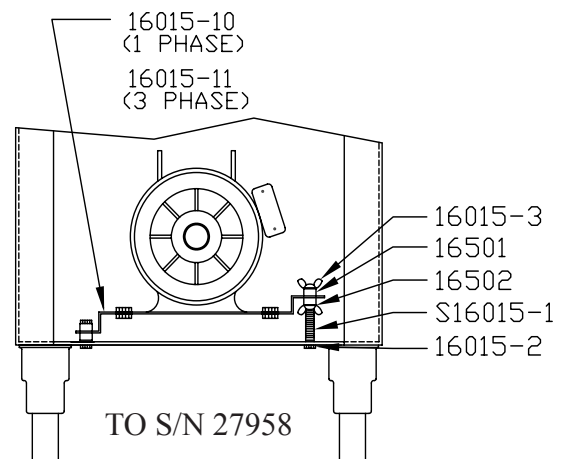

C. SAW GUIDE BAR AND SAW GUARD:

The factory recommends that when service is performed on any BIRO SAW the servicing agency be sure that the BIRO SAW is equipped with the most current safety features available.

In September 1969 the Model 3334 began production. The Model 3334 was first equipped with a 19" saw guide bar until March 1973 when the length was extended to 23". In June 1977, the bar was shortened to 22" and is used in current production.

The same saw guard (Part No. 255) on saw guide bar used on the Models 33 and 34 was carried over to the Model 3334 and used in production until June 1975.

Part No. 663 Saw Guard on saw guide bar replaced Part No. 255 in June 1976 starting with Serial No. 12242. At the same time, the Part No. 661 Guard on head Door introduced in 1974 was replaced by Part No. 661-1 Guard on Head Door. Both Part No. 663 and 661-1-DECA are current production today.

The factory recommends that all Model 3334's prior to Serial No. 12242 be updated by installing the current SAW GUIDE BAR ASSEMBLY (Part No. A116-22) and SAW GUARD ON HEAD DOOR (Part No. 661-1-DECA).

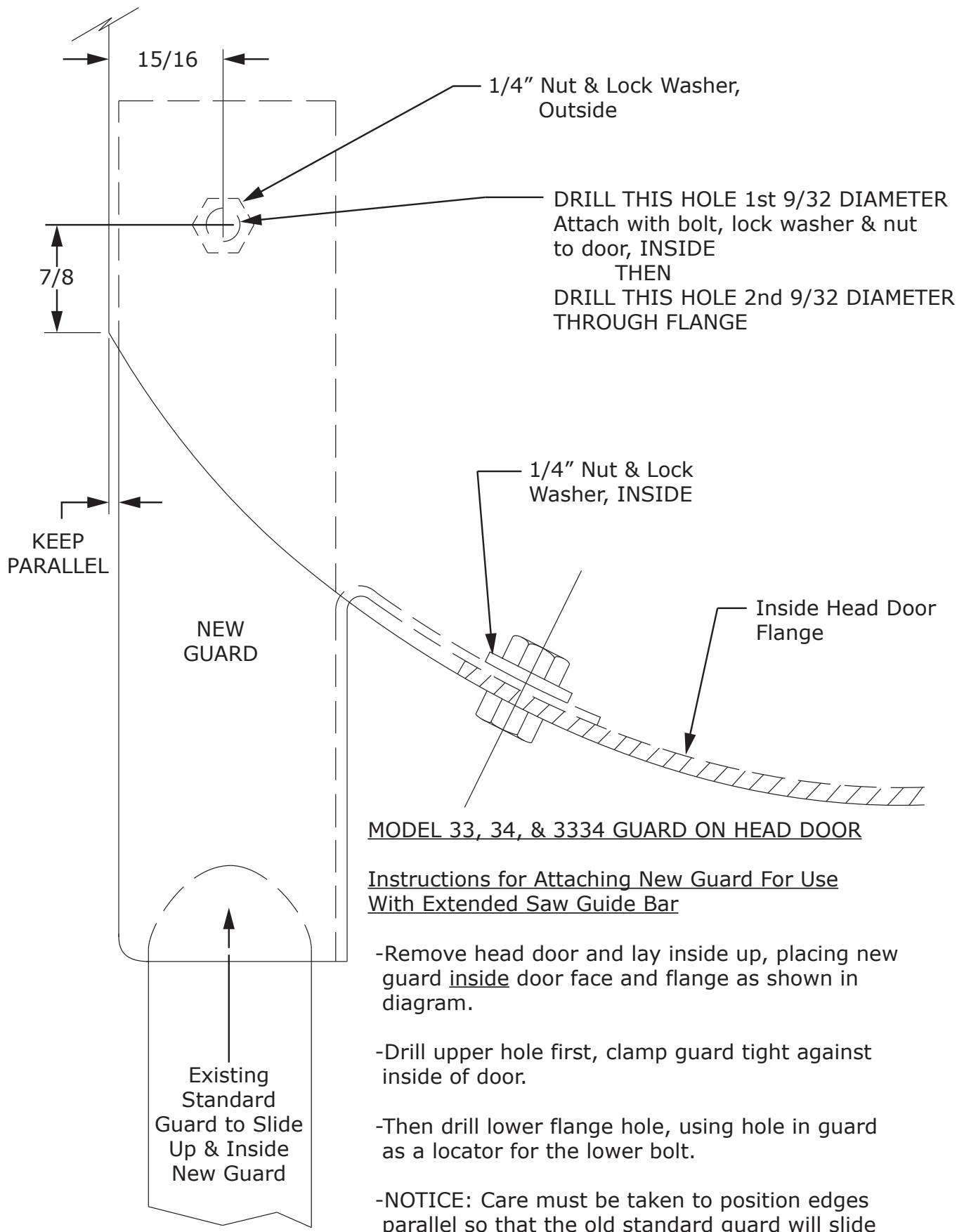

MODEL 33, 34, & 3334 GUARD ON HEAD DOOR

Instructions for Attaching New Guard For Use With Extended Saw Guide Bar

- Remove head door and lay inside up, placing new guard inside door face and flange as shown in diagram.
- Drill upper hole first, clamp guard tight against inside of door.
- Then drill lower flange hole, using hole in guard as a locator for the lower bolt.
- NOTICE: Care must be taken to position edges parallel so that the old standard guard will slide up inside the new guard.

LONGER SAW GUARD KIT

Item No. 663K

This longer guard is for replacement on existing saws. Install the new guard with the 1/4" diameter screws supplied with the Saw Guard Kit, Item No. 663K.

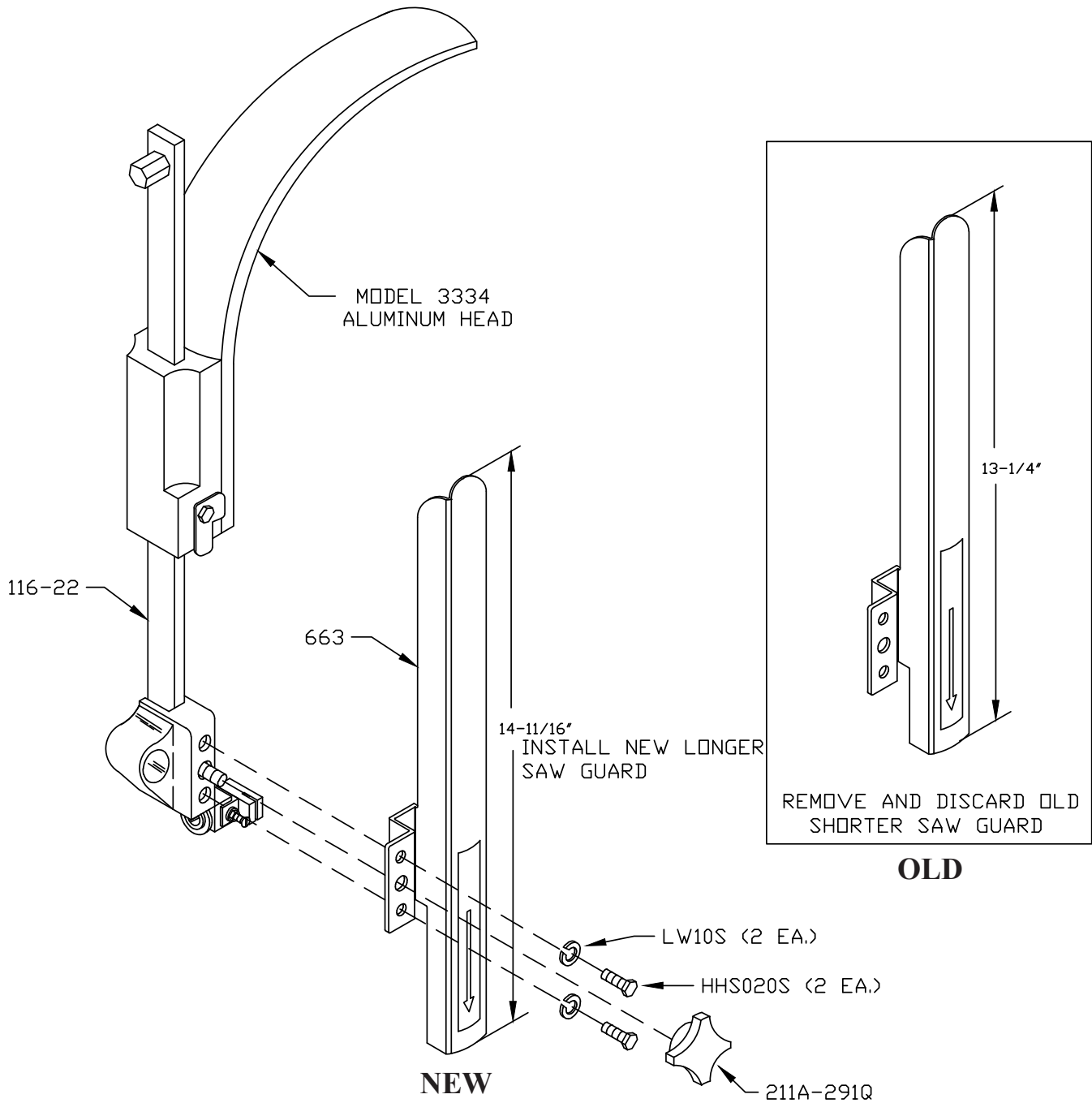

LONGER SAW GUARD KIT

Item No. 16662K

This longer guard is for replacement on existing saws. Install the new guard with the 1/4" diameter screws supplied with the Saw Guard Kit, Item No. 16662K.

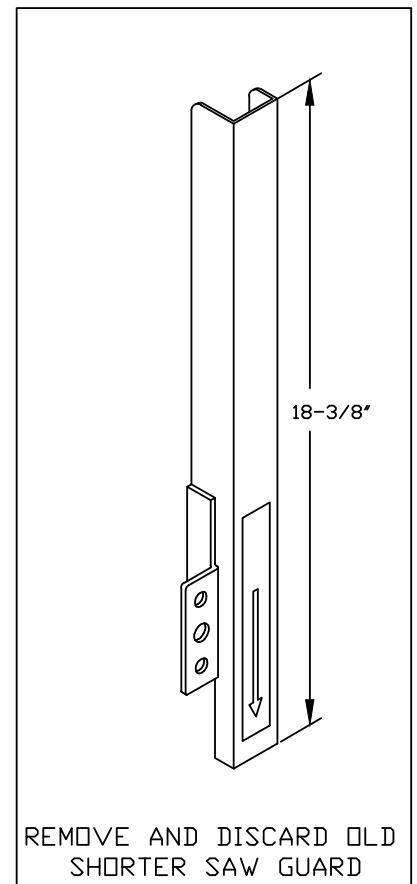
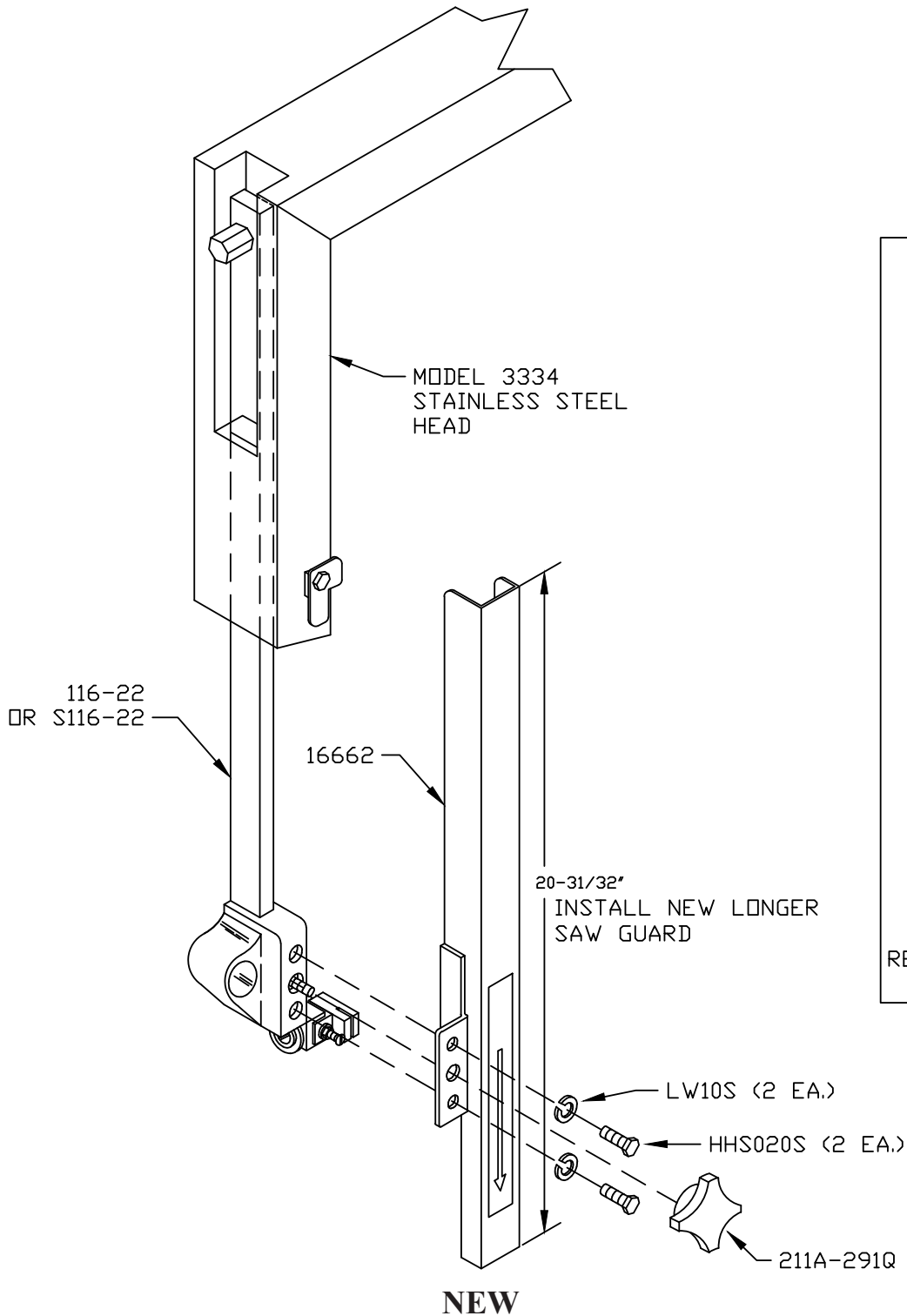

OLD

BASE DOOR HINGE SYSTEM

The Base Door Hinge System on the Model 3334 Series has been changed from an internal “plate and pin” system to an external “barrel and pin” system.

Effective Serial Numbers:

Old Style

Hinged Base Door with Internal Hinge Plates, #S16217R Before Serial No. 34386, and Serial Numbers 34442-34471

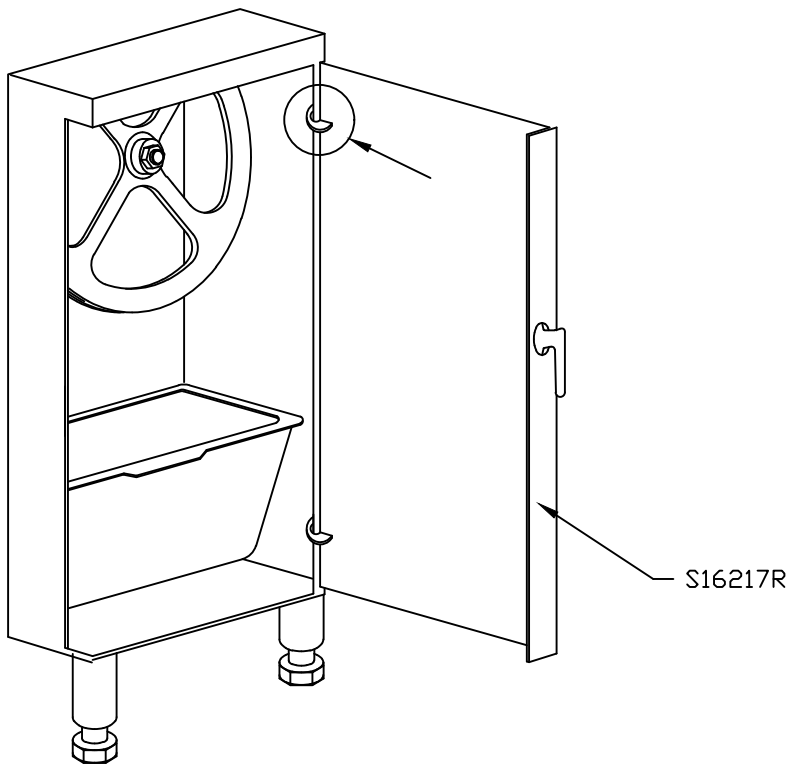

New Style

Hinged Base Door with External Hinge Plates, #S16217R-2 Serial Numbers 34386-34441 and Serial Numbers 34472 on

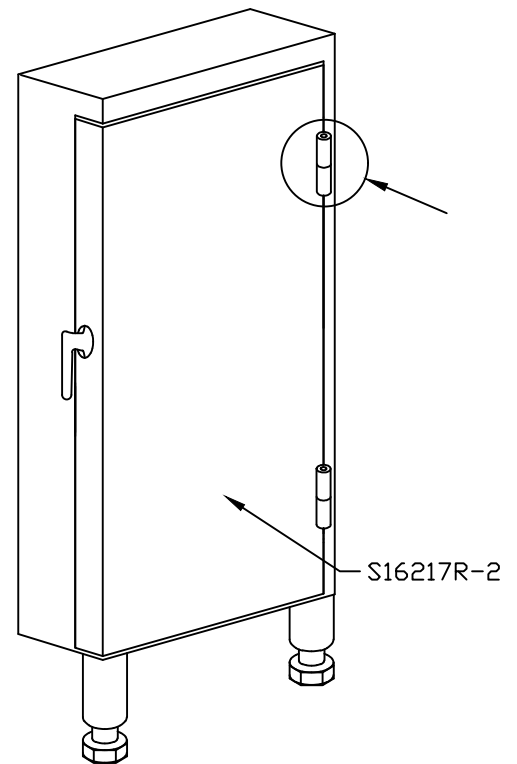

NEW DESIGN "FLAT TOP" BASE

Beginning with Serial No. 35323 on August 11, 1999, the Model 3334 and 3334-4003 base structure has been redesigned. The $\frac{9}{32}$ " offset (step down) on the front-top of the base for the stationary bar has been deleted. The base top now "flat" (see sketch below for Old Style and New Style part numbers for the base, right base door and stationary platter).

Effective Serial Numbers:

Old Style

Before Serial Number 35323

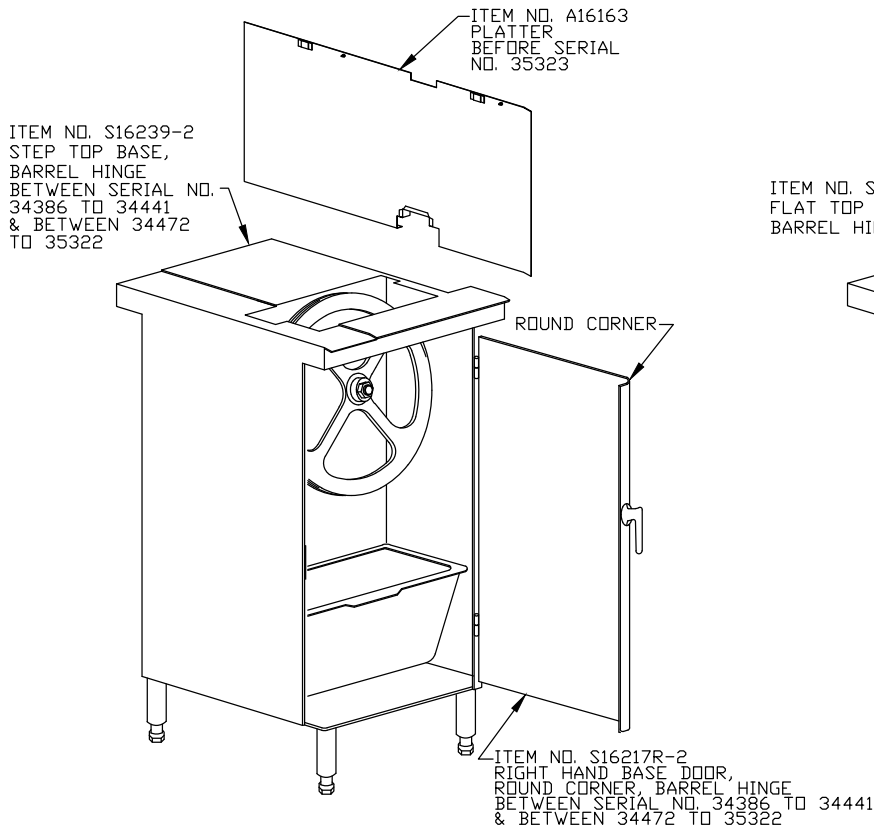

New Style

Starting with Serial Numbers 35323

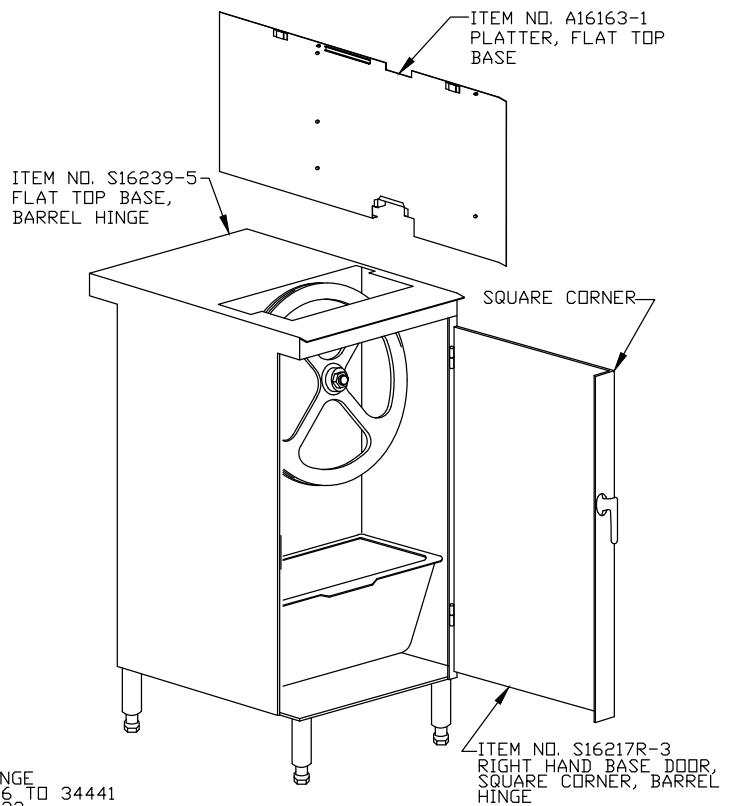

NOTE:
 ALWAYS REPORT MACHINE
 SERIAL NUMBER WHEN
 ORDERING PARTS

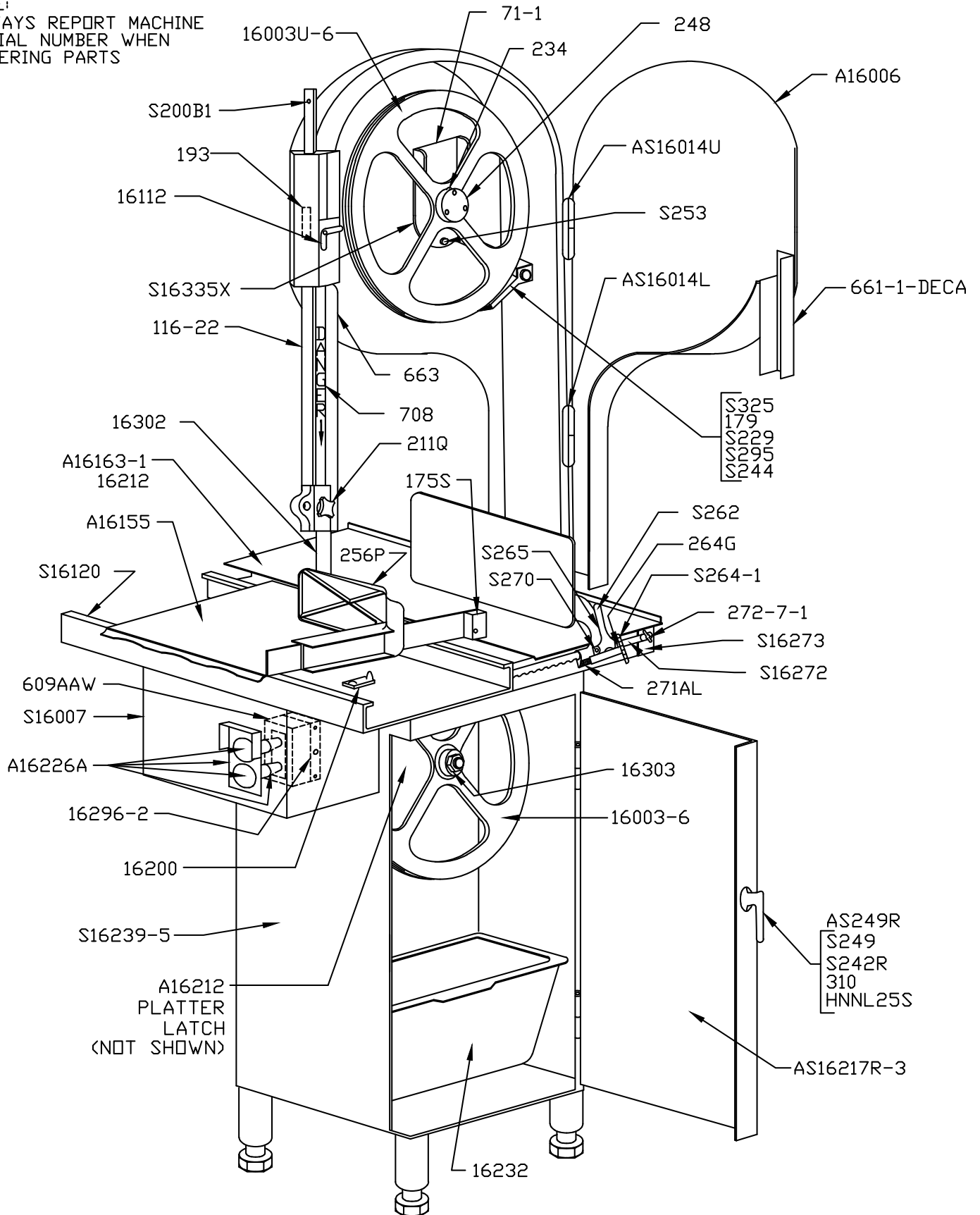

SPLIT PLATTER ASSEMBLY

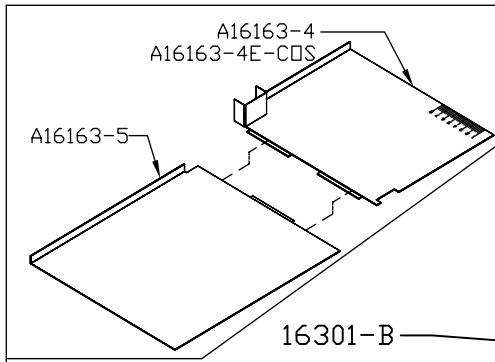

NOTE:
ALWAYS REPORT MACHINE SERIAL
NO. WHEN ORDERING PARTS.

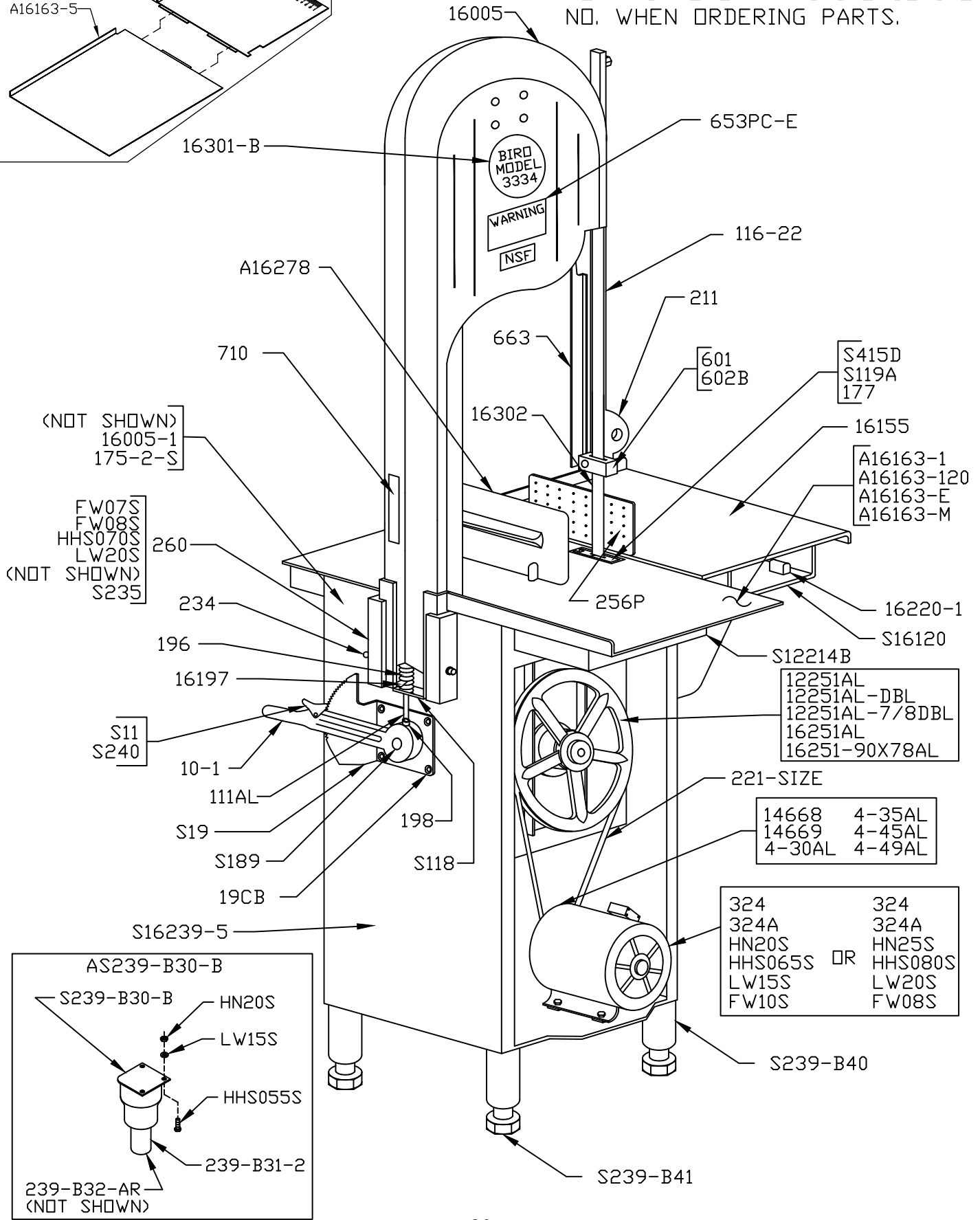

(NOT SHOWN)
16005-1
175-2-S

FW07S
FW08S
HHS070S
LW20S
(NOT SHOWN)
S235

S11
S240

12251AL
12251AL-DBL
12251AL-7/8DBL
16251AL
16251-90X78AL

14668 4-35AL
14669 4-45AL
4-30AL 4-49AL

324	324
324A	324A
HN20S	HN25S
HHS065S	HHS080S
LW15S	LW20S
FW10S	FW08S

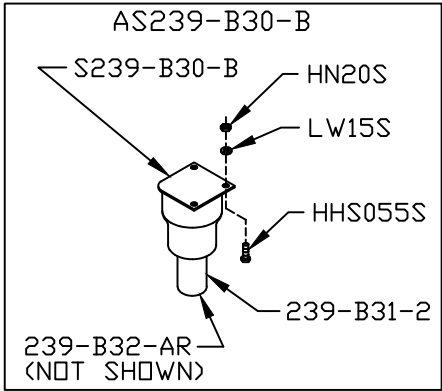

A16005 Head & Door Assembly

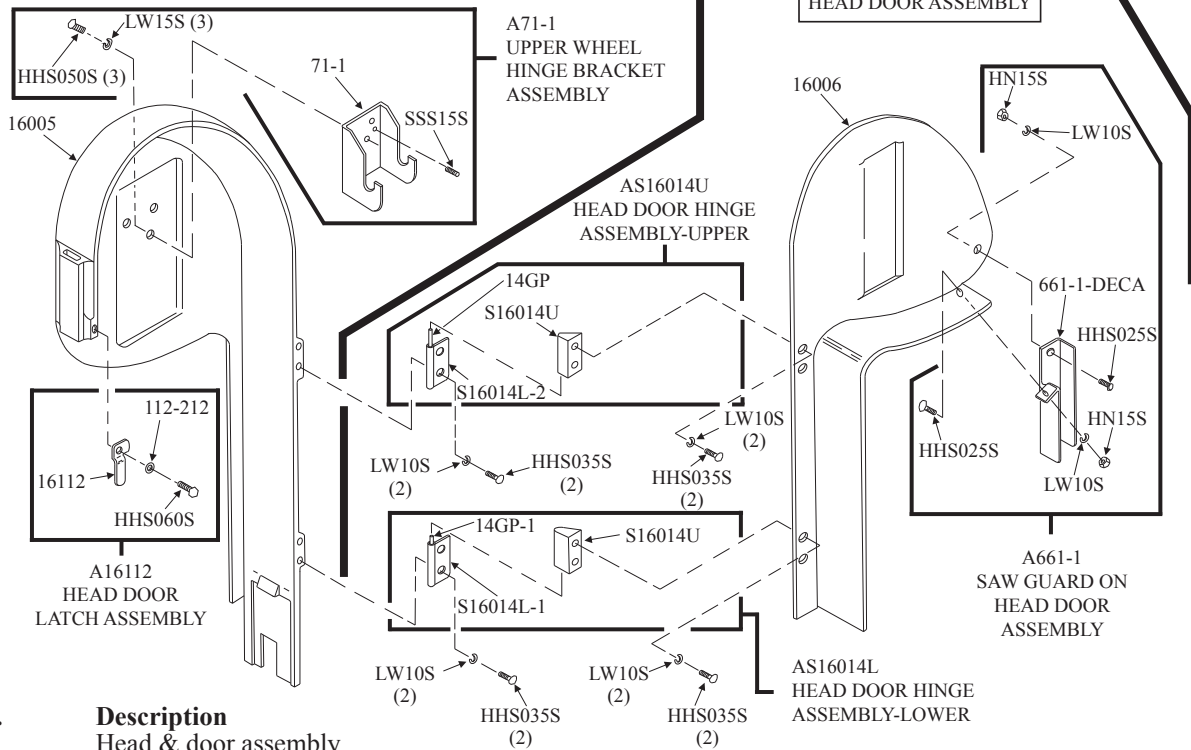

Item No.	Description
A16005	Head & door assembly
A16006	Head door assembly
A16112	Head door latch assembly
A661-1	Saw guard on head door assembly
A71-1	Upper wheel hinge bracket assembly
AS16014L	Head door hinge assembly - lower, SS
AS16014U	Head door hinge assembly - upper, SS
HHS025S	Hex head screw, 1/4-20 x 1/2, SS
HHS035S	Hex head screw, 1/4-20 x 5/8, SS
HHS050S	Hex head screw, 5/16-18 x 5/8, SS
HHS060S	Hex head screw, 5/16-18 x 1, SS
HN15S	Hex nut, 1/4-20, SS
LW10S	Lock washer, 1/4, SS

Item No.	Description
LW15S	Lock washer, 5/16 SS
SSS15S	Set screw, 5/16-18 x 5/16 cup point, SS
112-212	Waved washer
14GP	Head door hinge pin, 1 1/2"
14GP-1	Head door hinge pin, 1 1/4"
16005	Head, aluminum
16006	Head door, aluminum
16112	Head door latch
193	Guide bar spring - Not Shown
661-1-DECA	Saw guard to head door
71-1	Upper wheel hinge bracket

AS16005

Head & Door Assembly, SS

Item No.	Description
A16112	Head door latch assembly
AS16005	Head & door assembly, SS
AS16006	Head door assembly, SS
A71-1	Upper wheel hinge bracket assembly
HHS050S	Hex head screw, 5/16-18 x 5/8, SS
HHS060S	Hex head screw, 5/16-18 x 1, SS
LW15S	Lock washer, 5/16 SS
SSS15	Set screw, 5/16-18 x 5/16
S16005C	Head, SS
S16006	Head door, SS
193	Guide bar spring, Not Shown
194	Locking knob pad, Not Shown
194KS-1	Saw guide bar lock knob, SS head
71-1	Upper wheel hinge bracket

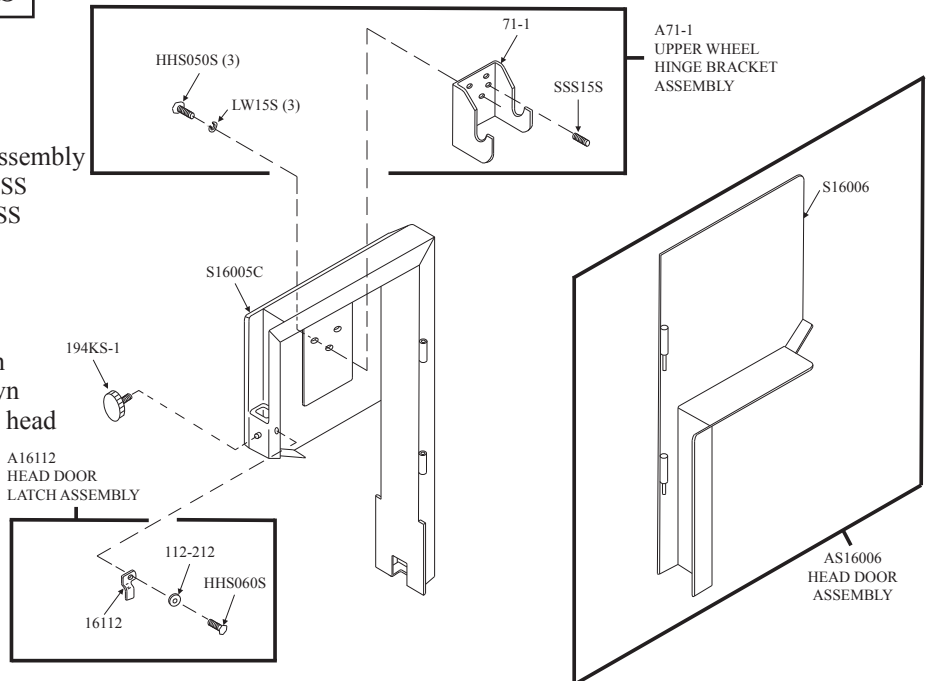

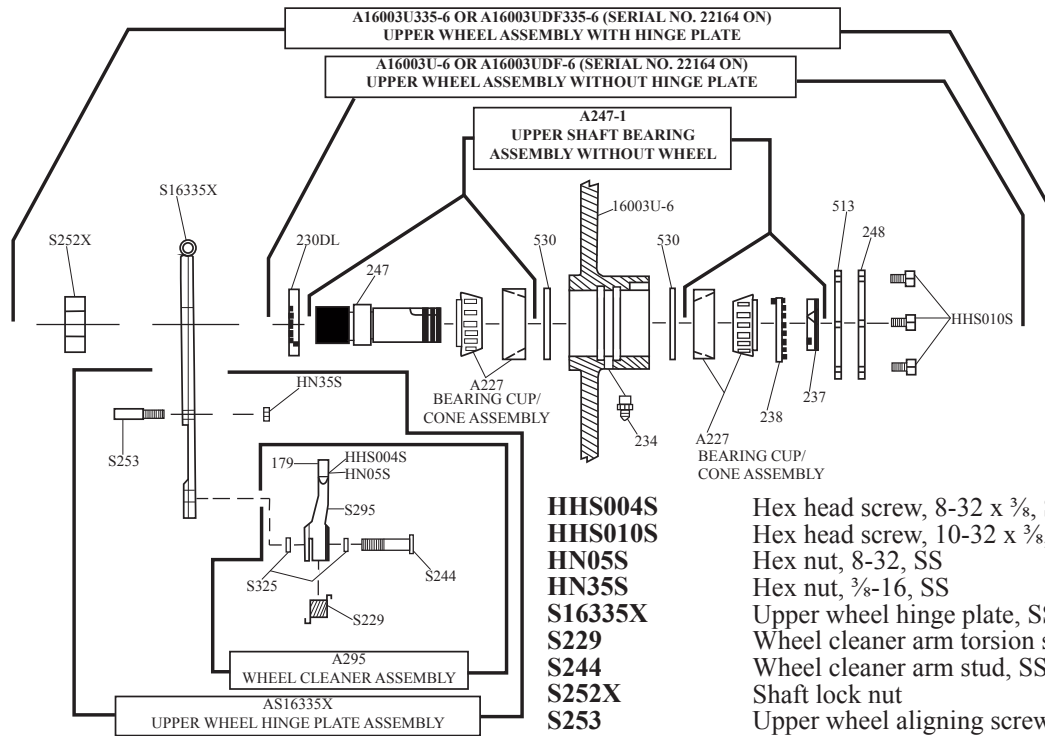

Item No.	Description	Item No.	Description
A16003U-6	Upper wheel assembly without hinge plate	HHS004S	Hex head screw, 8-32 x 3/8, SS
A16003U335-6	Upper wheel assembly with hinge plate	HHS010S	Hex head screw, 10-32 x 3/8, SS
A16003UDF-6	Upper double flange wheel assembly without hinge plate	HN05S	Hex nut, 8-32, SS
A16003UDF335-6	Upper double flange wheel assembly with hinge plate	HN35S	Hex nut, 3/8-16, SS
A247-1	Upper shaft bearing assembly less spacer	S16335X	Upper wheel hinge plate, SS
AS16335X	Upper wheel hinge plate assembly	S229	Wheel cleaner arm torsion spring, SS
A227	Bearing cup/cone assembly	S244	Wheel cleaner arm stud, SS
A295	Wheel cleaner assembly	S252X	Shaft lock nut
		S253	Upper wheel aligning screw, SS
		S295	Wheel cleaner arm, SS
		S325	Wheel cleaner washer, SS
		16003U-6	Upper wheel, 16", 6 spoke
		179	Wheel cleaner
		230DL	Upper shaft seal, double lip
		234	Grease fitting, upper wheel
		237	Upper shaft castellated lock nut
		238	Upper shaft castellated lock nut washer
		247	Upper shaft
		248	Upper wheel hub cap
		513	Upper wheel hub gasket
		530	Retaining ring, (2 req.)

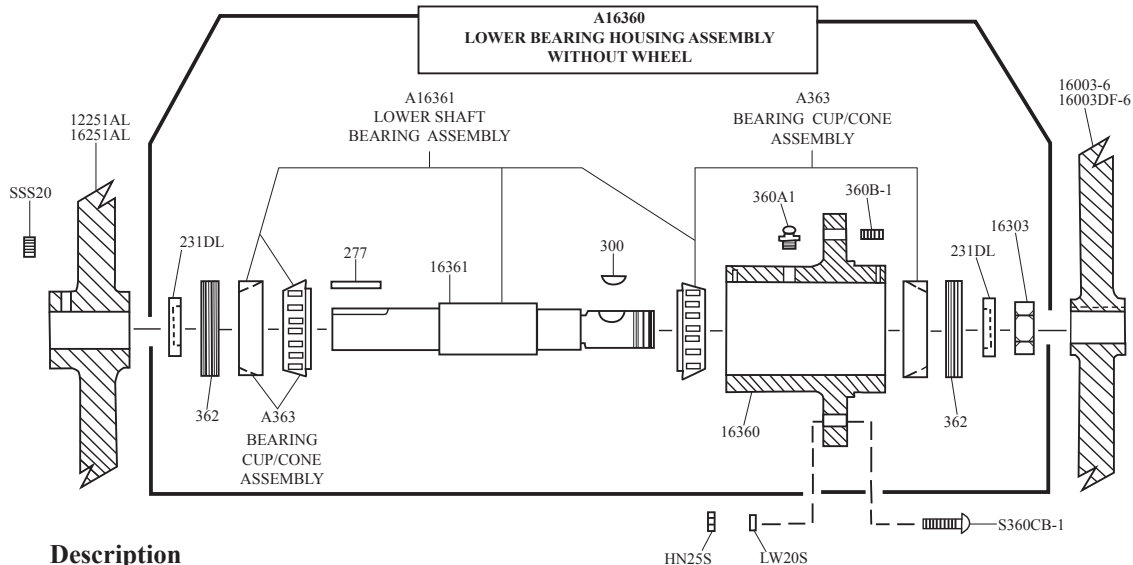

Item No.	Description	Item No.	Description
A16360	Lower bearing housing assembly w/o wheel	16251AL	Upper V-belt pulley 11.4 x 1 aluminum
A16361	Lower shaft bearing assembly	16303	Lower shaft nut
A363	Lower bearing cup/cone assembly	16360	Lower bearing housing
HN25S	Hex nut, 3/8 -16 SS	16361	Lower shaft
LW20S	Lock washer, 3/8 SS	231DL	Lower shaft seal, double lip
SSS20	Set screw, 3/8 -16 x 3/8 cup point, SS	277	Lower shaft key
S360CB-1	Carriage bolt, 3/8 -16 x 1 1/4, SS	300	Lower shaft Woodruff key
12251AL	Upper V-belt pulley, 9 x 1 aluminum	360A1	Grease fitting
16003-6	Lower wheel 16", 6 spoke	360B-1	Set screw, 1/2 -13 x 1/2 flat point
16003DF-6	Lower double flange wheel 16", 6 spoke	362	Lower bearing housing adjusting cap

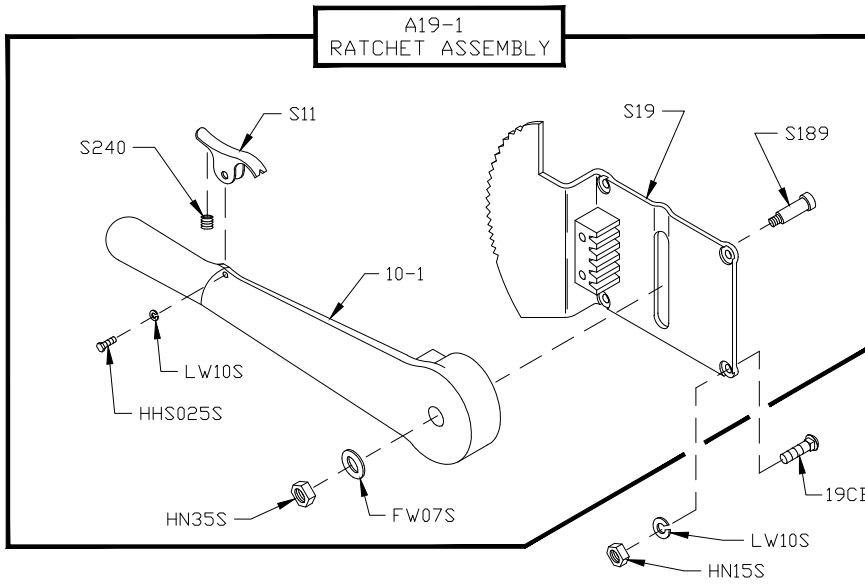

Item No.	Description
A19-1	Ratchet assembly
FW07S	Flat washer, 3/8 SS
HHS040S	Hex head screw, 1/4-20 x 3/4 SS
HN15S	Hex nut, 1/4-20 SS
HN35S	Hex nut, 3/8-16 SS
LW10S	Lock washer, SS
S11	Ratchet trigger, SS
S189	Ratchet arm stud, SS
S19	Ratchet base, SS
10-1	Ratchet arm
19CB	Carriage bolt, 1/4-20 x 3/4 SS
S240	Ratchet trigger spring, SS

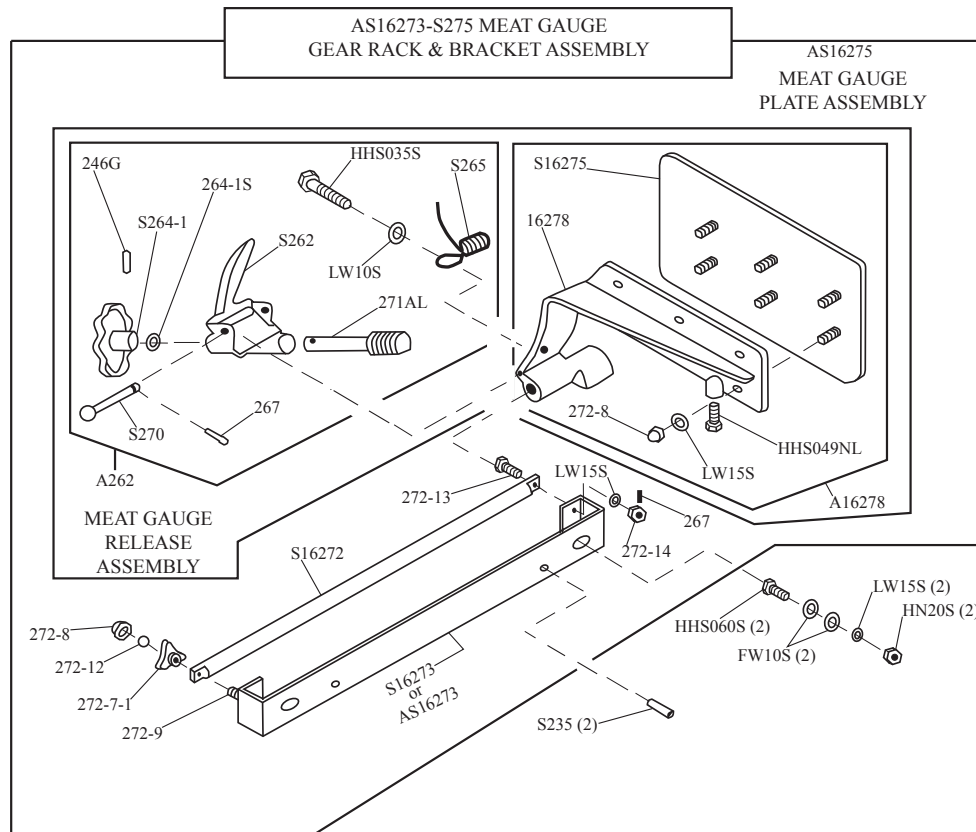

Item No.	Description
A16278	Meat gauge plate assembly less release assembly
A262	Meat gauge release assembly
AS16273	Meat gauge bracket assembly
AS16273-S275	Meat gauge gear rack & bracket assembly
AS16275	Meat gauge plate assembly with release ass'y
FW10S	Flat washer, 5/16, SS
HHS035S	Hex head screw, 1/4-20 x 5/8
HHS049NL	Hex head screw, 5/16-20 x 1/2, nylon
HHS060S	Hex head screw, 5/16-18 x 1, SS
HN20S	Hex nut, 5/16-18, SS
LW10S	Lock washer, 1/4, SS
LW15S	Lock washer, 5/16, SS
S16272	Meat gauge gear rack, SS
S16273	Meat gauge bracket, SS
S16275	Meat gauge plate, SS

S235	Taper pin, # 4 x 3/4", SS
S262	Meat gauge release handle, SS
S264-1	Meat gauge hand wheel, SS
S265	Meat gauge release spring
S270	Meat gauge release pin
16278	Meat gauge arm
264G	Meat gauge hand wheel groove pin
264-1S	Hand wheel shim
267	Meat gauge release cotter pin
271AL	Meat gauge worm gear, aluminum
272-7-1	Lock knob, 5/16-18, 3 point
272-8	Cap nut, 5/16-18, SS
272-9	Hex bolt, 5/16-18 x 2 SS
272-12	Brass ball
272-13	Hex head screw, 5/16-18 x 1 1/4, SS
272-14	Castellated nut, 5/16-18, SS

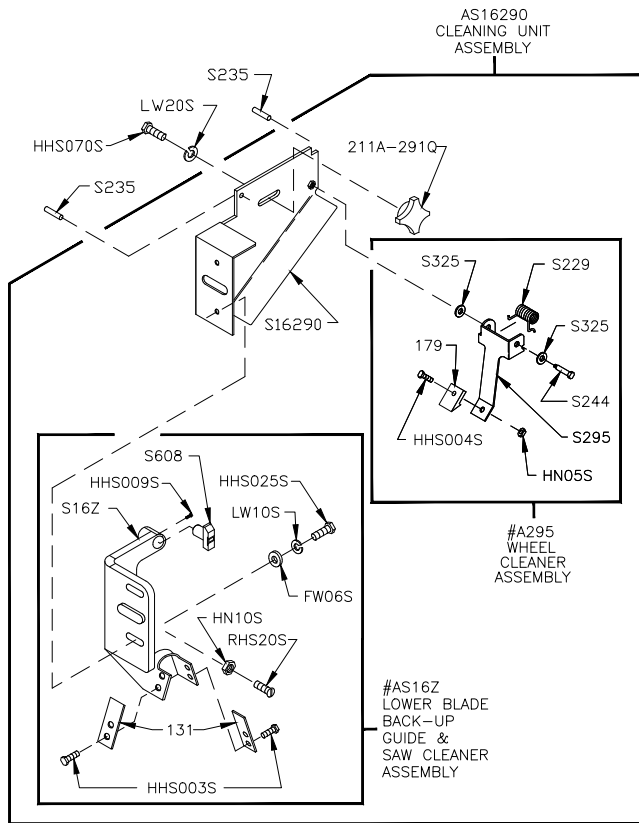

Item No.	Description
A295	Wheel cleaner assembly
AS16290	Cleaning unit total assembly
AS16Z	Guide bracket saw cleaner assembly, SS
FW06S	Flat washer, 1/4 SS
HHS003S	Hex head screw, 8-32 x 1/4 SS
HHS004S	Hex head screw, 8-32 x 3/8, SS
HHS009S	Hex head screw, 10-24 x 1/4, SS
HHS025S	Hex head screw, 1/4-20 x 1/2, SS
HHS070S	Hex head screw, 3/8-16 x 1, SS
HN05S	Hex nut, 8-32, SS
HN10S	Hex nut, 10-32, SS
LW10S	Lock washer, 1/4 SS
LW20S	Lock washer, 3/8 SS
RHS20S	Round head screw 10-32 x 1 1/8 SS
S16Z	Lower guide bracket saw cleaner holder, SS
S16290	Cleaning unit stamping, SS
S229	Wheel cleaner arm torsion spring, SS
S235	Taper pin, 4 x 3/4, SS
S244	Wheel cleaner arm stud, SS
S295	Wheel cleaner arm, SS
S325	Wheel cleaner washer, SS
S608	Saw backup guide with carbide
131	Saw cleaner SS
179	Wheel cleaner
211A-291Q	Fastener knob, 4 point

SAW GUIDE BAR ASSEMBLY

Item No.	Description
A116-22AL	Steel saw guide bar assembly, 22" Al head
A116-22SS	Steel saw guide bar assembly, 22" SS head
A116-22-COS	Saw guide bar assembly 22", Special
AS116-22-COS	Saw guide bar assembly 22", SS, Special
AS116-22	Saw guide bar ass'y w/lock knob 22", Al head
AS116-22SS	Saw guide bar ass'y w/lock knob 22", SS head
A211-AL	Finger lift assembly, removable, Al head
A211-SS	Finger lift assembly, removable, SS head
A211-COS	Finger lift assembly, removable, SS, Special
A602	Saw guide assembly, upper
FW06S	Flat washer, 1/4 SS
HHS015S	Hex head screw, 10-32 x 7/8 SS
HHS020S	Hex head screw, 1/4-20 x 3/8 SS
HHS083S	Hex head screw, 3/8-16 x 1 3/4 SS
HN10S	Hex nut, 10-32 SS
LW05S	Lock washer, #10 SS
LW10S	Lock washer, 1/4 SS
RHS10S	Round head screw, 10-32 x 3/4 SS
RHS30S	Round head screw, 1/4-20 x 7/8 SS
S116-22	Saw guide bar, 22" SS
S116-22-COS	Saw guide bar, 22" SS, Special
S200B1	Stop stud on guide bar
116-22	Saw guide bar, 22"
116KS	Saw guide bar lock knob- Al head
16662	Saw guard for SS head
16662-COS	Saw guard for SS head, Special
17211-22	Finger lift, shim, .022
17211-35	Finger lift, shim, .035
193	Saw guide bar spring, for steel saw guide bar
194	Saw guide bar lock pad, for SS saw guide bar
194KS-1	Saw guide bar lock knob
211	Finger lift bracket
211A-291Q	Fastener knob, 4 point
601	Upper saw guide bracket
602B	Upper saw guide with carbide

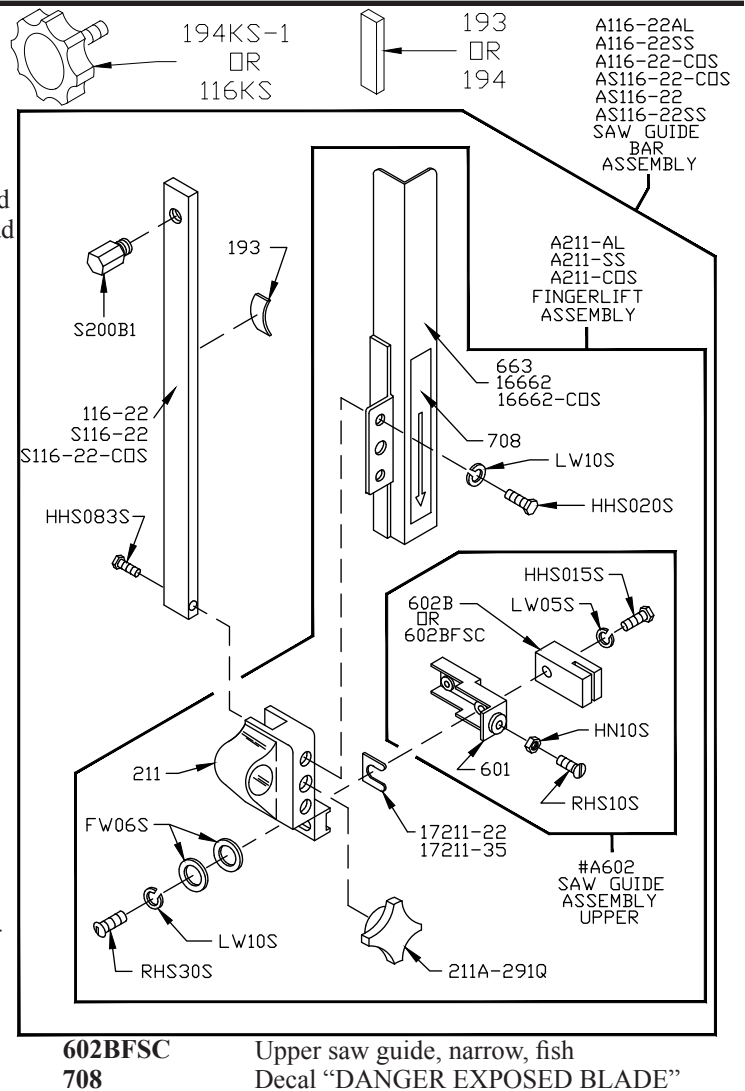

**A415D
STATIONARY BAR ASSEMBLY**

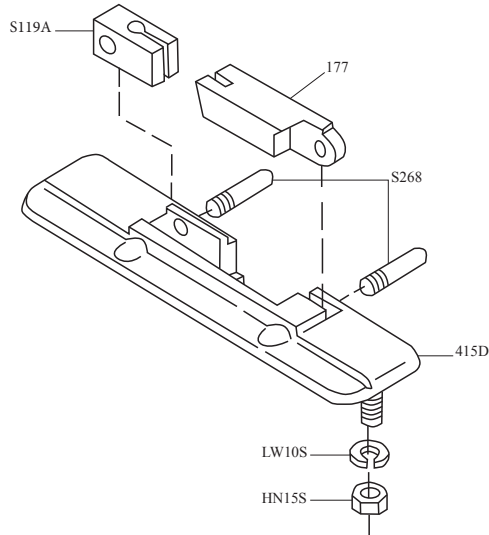

Item No.	Description
A415D	N/A, use AS415D
HN15S	Hex nut, 1/4-20 SS
LW10S	Lock washer, 1/4 SS
S119A	Saw guide in stationary bar, SS
S268	Stationary bar headless screw
177	Nylon filler
415D	Stationary bar, N/A, use S415DK

**AS16132 REAR STEEL
CLEANER ASSEMBLY**

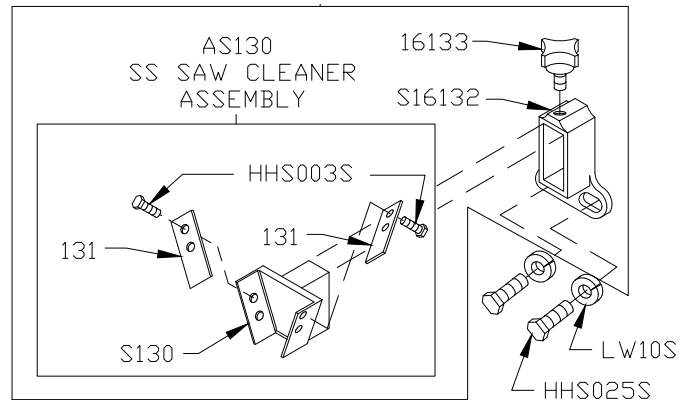

Item No.	Description
AS130	Saw cleaner assembly, SS
AS16132	Rear saw blade cleaner assembly, SS
HHS003S	Hex head screw 8-32 x 1/4", SS
HHS025S	Hex head screw 1/4-20 x 1/2", SS
S130	Saw cleaner bracket, rear, SS
S16132	Saw cleaner bracket holder, rear, SS
131	Saw cleaner, SS
16133	Fastener knob - 4 point

**AS415D
STATIONARY BAR
ASSEMBLY, SS**

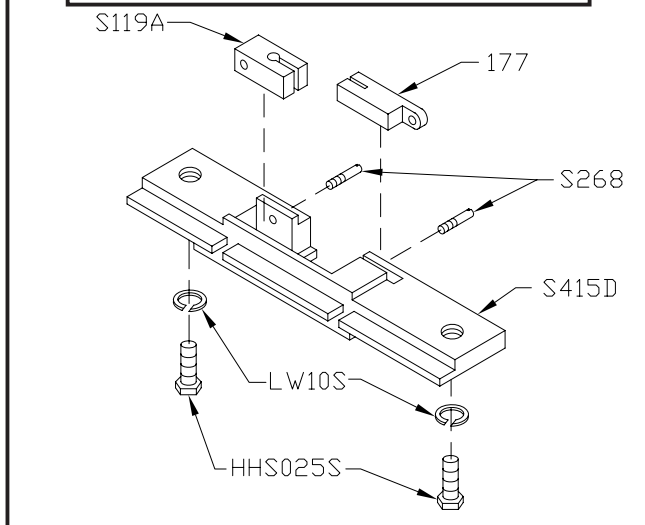

Item No.	Description
AS415D	Stationary bar assembly, SS
HHS025S	Hex head screw, 1/4-20 x 1/2 SS
LW10S	Lock washer, 1/4 SS
S268	Stationary bar headless screw
S119A	Saw guide in stationary bar, SS
S415D	Stationary bar, SS
177	Nylon filler

**A16196
TENSION
SPRING
ASSEMBLY**

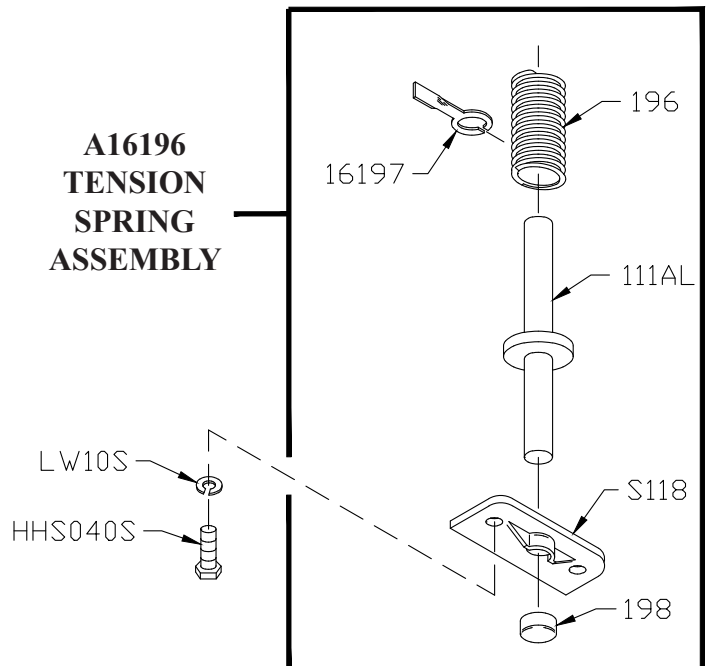

Item No.	Description
A16196	Tension spring assembly
HHS040S	Hex head screw, 1/4-20 x 3/4 SS
LW10S	Lock washer, 1/4 SS
111AL	Tension spring pin, Aluminum
S118	Tension spring plate
16197	Tension spring gauge
196	Saw tension spring
198	Cap, for tension pin

STANDARD 3334 MEAT CARRIAGE & CHANNEL

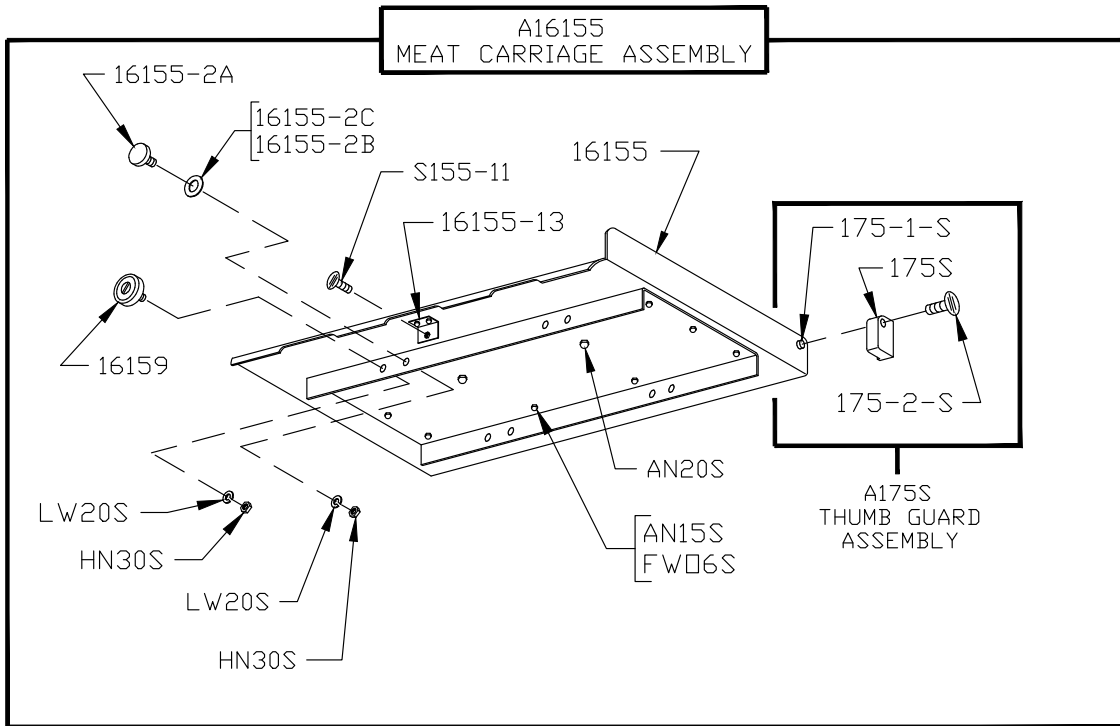

Item No.	Description	Item No.	Description
A16155	Meat carriage assembly complete	16155	Meat carriage top & angle only
A175S	Thumb guard assembly	16155-13	Carriage stop angle SS, welded
FW06S	Flat washer, 1/4 SS	16155-2A	Meat carriage guide
AN15S	Acorn nut, 1/4-20 SS	16155-2B	Meat carriage guide spacer, 1/64 thick
AN20S	Acorn nut, 3/8-16 SS	16155-2C	Meat carriage guide spacer, 1/32 thick
HN30S	Hex nut, 3/8-16 light jam, SS	16155AEZ-1	Meat carriage angle plate (DNS)
LW20S	Lock washer, 3/8 regular, SS	16159	Meat carriage angle plate (DNS)
S155-11	Meat carriage stop thumb screw	175S	Thumb guard, nylon
S155	Meat carriage top only (NSS)	175-1-S	Thumb guard nut, SS
S155-R	Raw meat carriage top only (DNS)	175-2-S	Thumb screw, 1/4-20 x 1/2, SS

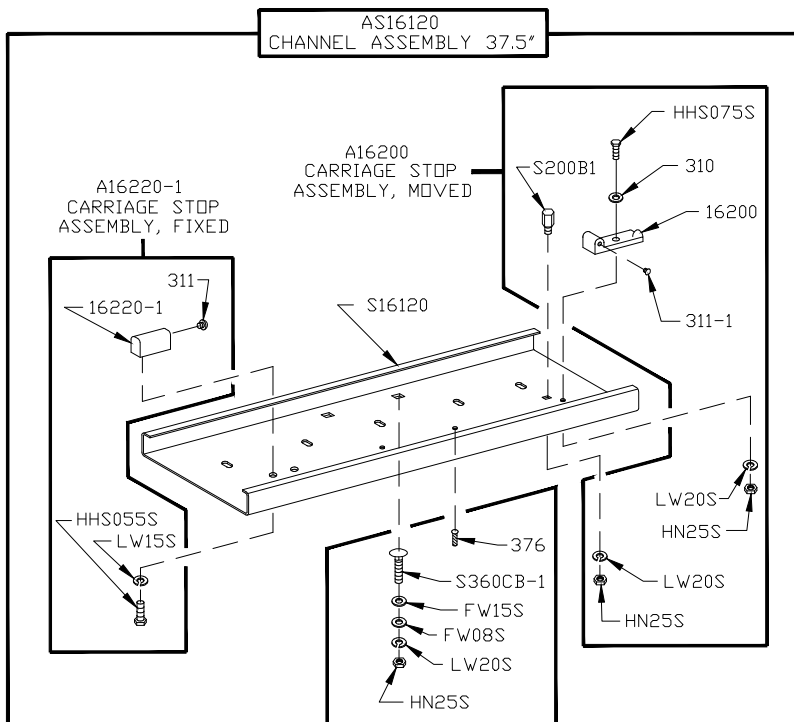

Item No.	Description
A16200	Carriage stop assembly, movable
A16220-1	Carriage stop assembly, fixed
AS16120	Channel assembly, 37.5"
FW08S	Flat washer, 3/8 SS
FW15S	Flat washer, 1/2 SS
HHS055S	Hex head screw, 5/16-18 x 3/4 SS
HHS075S	Hex head screw, 3/8-16 x 1 1/4 SS
HN25S	Hex nut, 3/8-16 SS
LW15S	Lock washer 5/16 SS
LW20S	Lock washer 3/8 SS
S16120	Channel, 37" SS
S200B1	Stop stud SS, guide bar & carriage stop
S360CB-1	Carriage bolt, 3/8-16 x 1 1/4 SS
16200	Carriage stop, movable
16220-1	Carriage stop, fixed
310	Waved washer
311	Rubber bumper, fixed stop
311-1	Rubber bumper, movable stop
376	Drive screw #10 x 1/2 SS

OPTIONAL 3334 EZ FLOW MEAT CARRIAGE & CHANNEL

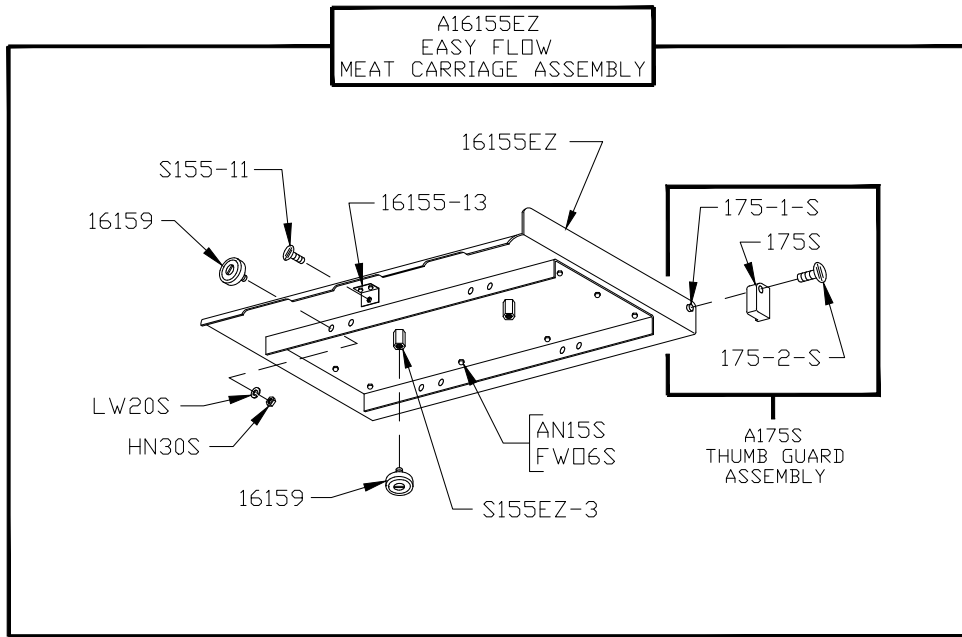

Item No.	Description	Item No.	Description
A16155EZ	Meat carriage assembly complete - EZ Flow	S155EZ-3	Hex stand-off, EZ Flow carriage
A175S	Thumb guard assembly	16155EZ	Meat carriage top & angle only
AN15S	Acorn nut, 1/4-20 SS	16155EZ-1	Meat carriage top only w/ weld studs (DNS)
FW06S	Flat washer, 1/4 SS	16155-13	Carriage stop angle SS, welded
HN30S	Hex nut, 3/8-16 light jam, SS	16155AEZ-1	Meat carriage angle plate (DNS)
LW20S	Lock washer, 3/8 regular, SS	16159	Meat carriage bearing SS
S155-11	Meat carriage stop thumb screw	175S	Thumb guard, nylon
S155EZ	Meat carriage top only (NSS)	175-1-S	Thumb guard nut, SS
S155-R	Raw meat carriage top only (DNS)	175-2-S	Thumb screw, 1/4-20 x 1/2, SS

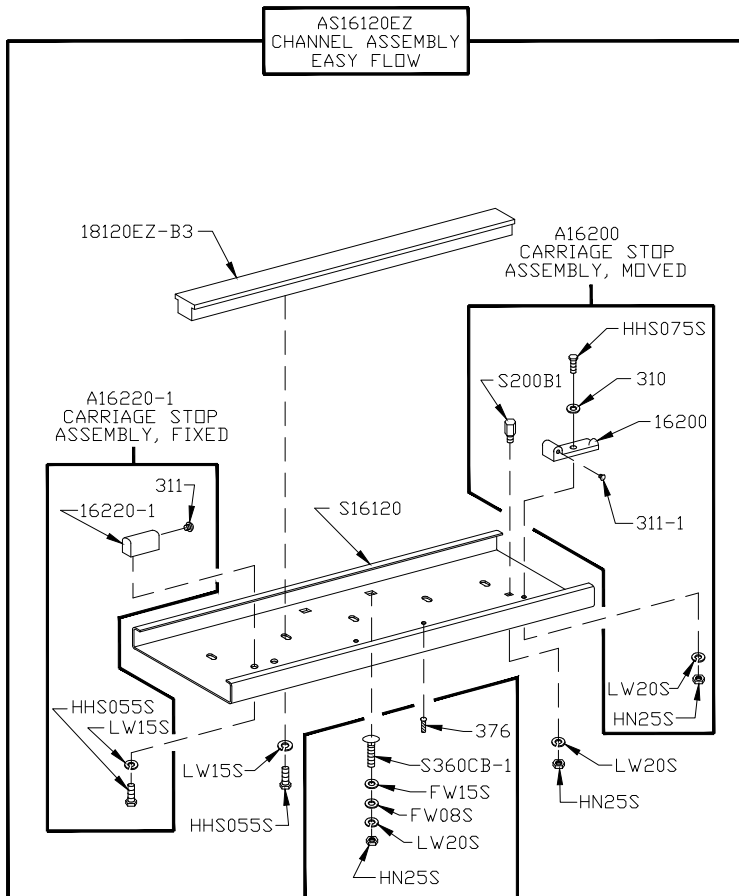

Item No.	Description
A16200	Carriage stop assembly, movable
A16220-1	Carriage stop assembly, fixed
AS16120EZ	Channel assembly, 37" EZ Flow
FW08S	Flat washer, 3/8 SS
FW15S	Flat washer, 1/2 SS
HHS055S	Hex head screw, 5/16-18 x 3/4 SS
HHS075S	Hex head screw, 3/8-16 x 1 1/4 SS
HN25S	Hex nut, 3/8-16 SS
LW15S	Lock washer 5/16 SS
LW25S	Lock washer 3/8 SS
S16120	Channel, 37" SS
S200B1	Stop stud SS, guide bar & carriage stop
S360CB-1	Carriage bolt, 3/8-16 x 1 1/4 SS
16200	Carriage stop, movable
16220-1	Carriage stop, fixed
18120EZ-B3	Guide bar - EZ Flow
310	Waved washer
311	Rubber bumper, fixed stop
311-1	Rubber bumper, movable stop
376	Drive screw #10 x 1/2 SS

STANDARD ON 3334-4003 EZ FLOW MEAT CARRIAGE & CHANNEL
ALSO OPTIONAL ON ALL OTHER 3334

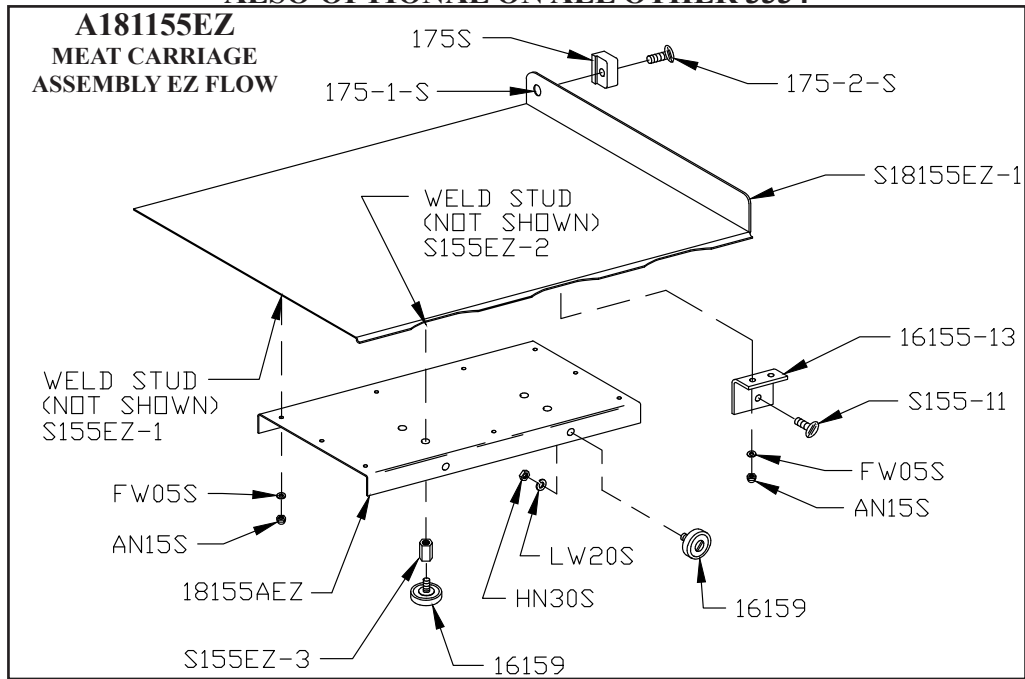

Item No.	Description	Item No.	Description
A175S	Thumb guard assembly	S181155AEZ	Meat carriage angle - EZ Flow
A181155EZ	Meat carriage assembly, EZ Flow	S18155EZ-1	Carriage top w/ weld studs
AN15S	Acorn nut, 1/4-20 SS	16155-13	Carriage stop angle SS
FW06S	Flat washer, 1/4 SS	16159	Carriage bearing
HN30S	Hex nut, 3/8-16 light jam, SS	175S	Thumb guard - Nylon
LW20S	Lock washer, 3/8 regular, SS	175-1-S	Thumb guard nut, SS
S155-11	Meat carriage stop thumb screw	175-2-S	Thumb screw, 1/4-20 x 1/2, SS
S155EZ-3	Hex stand off - EZ Flow carriage		

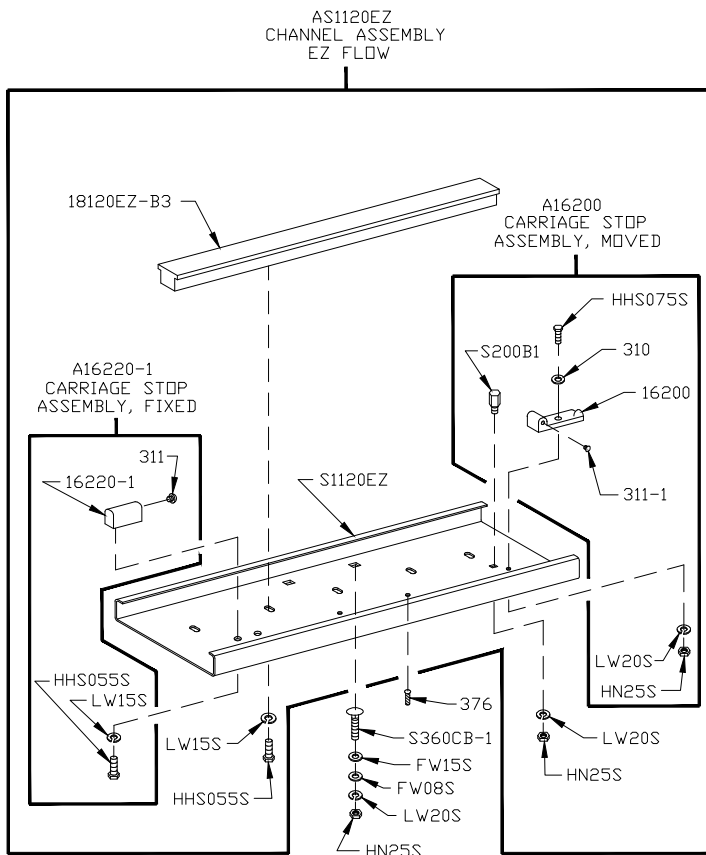

Item No.	Description
A16200	Carriage stop assembly, movable
A16220-1	Carriage stop assembly, fixed
AS1120EZ	Channel assembly, EZ Flow
FW08S	Flat washer, 3/8 SS
FW15S	Flat washer, 1/2 SS
HHS055S	Hex head screw, 5/16-18 x 3/4 SS
HHS075S	Hex head screw, 3/8-16 x 1 1/4 SS
HN25S	Hex nut, 3/8-16 SS
LW15S	Lock washer 5/16 SS
LW20S	Lock washer 3/8 SS
S1120EZ	Channel, EZ Flow
S200B1	Stop stud, SS
S360CB-1	Carriage bolt, 3/8-16 x 1 1/4 SS
16200	Carriage stop, movable
16220-1	Carriage stop, fixed
18120EZ-B3	Guide bar, EZ Flow
310	Waved washer
311	Rubber bumper, fixed stop
311-1	Rubber bumper, movable stop
376	Drive screw #10 x 1/2 SS
NOT SHOWN	
S1007	Channel bracket, SS

**S16217L
BASE DOOR LEFT, SS**

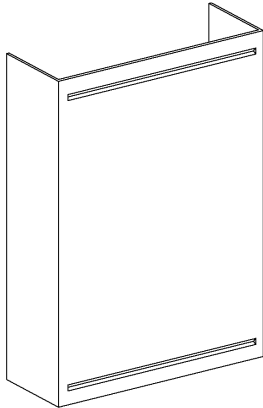

USE WITH

Motor Mfg.	Model No.	Specifications
Doerr	XR72927	1-1/2HP, 220/440-50/60-3 open
Doerr	R72929	2HP, 220/440-50/60-3 open
U.S. Motor	G54313	2HP, 220/440-50/60-3 open
Doerr	73020	2HP, 550-60-3 open
U.S. Motor	G57016	2HP, 550-60-3 open

**S16217LTP
BASE DOOR, LEFT TAPERED PANEL, SS**

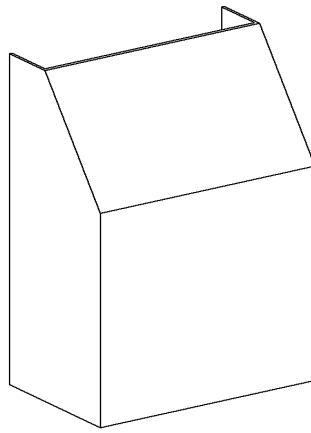

USE WITH

Motor Mfg.	Model No.	Specifications
Doerr	73032	1-1/2HP, 115/230-50-1 open
U.S. Motor	G57347	1-1/2HP, 115/230-50-1 open
Doerr	72933	1-1/2HP, 115/230-60-3 open
Baldor	L3605	2HP, 115/230-60-1 TE
Baldor	L3605-50	2HP, 115/230-50-1 TE
Baldor	L1322T	2HP, 115/230-60-1 open
Doerr	67385	2HP, 208/220/440-50/60-3 TE
Baldor	M3558T-5	2HP, 550-60-3 TE
Baldor	M3558T-50	2HP, 220/380/415-50-3 TE
Baldor	M3558T-8	2HP, 200-60-3 TE
Doerr	72540	3HP, 220/440-50/60-3 TE
Doerr	75425	3HP, 220/440-50/60-3 TE
U.S. Motor	G57011	3HP, 220/440-50/60-3 TE
Baldor	M3611	3HP, 220/440-50/60-3 TE
Baldor	M3611T-50	3HP, 220/380/440-50-3 TE
Baldor	M3611T-8	3HP, 200-60-3 TE
Doerr	73031	5HP, 220/440-50/60-3 TE
Doerr	A907	5HP, 220/440-50/60-3 TE

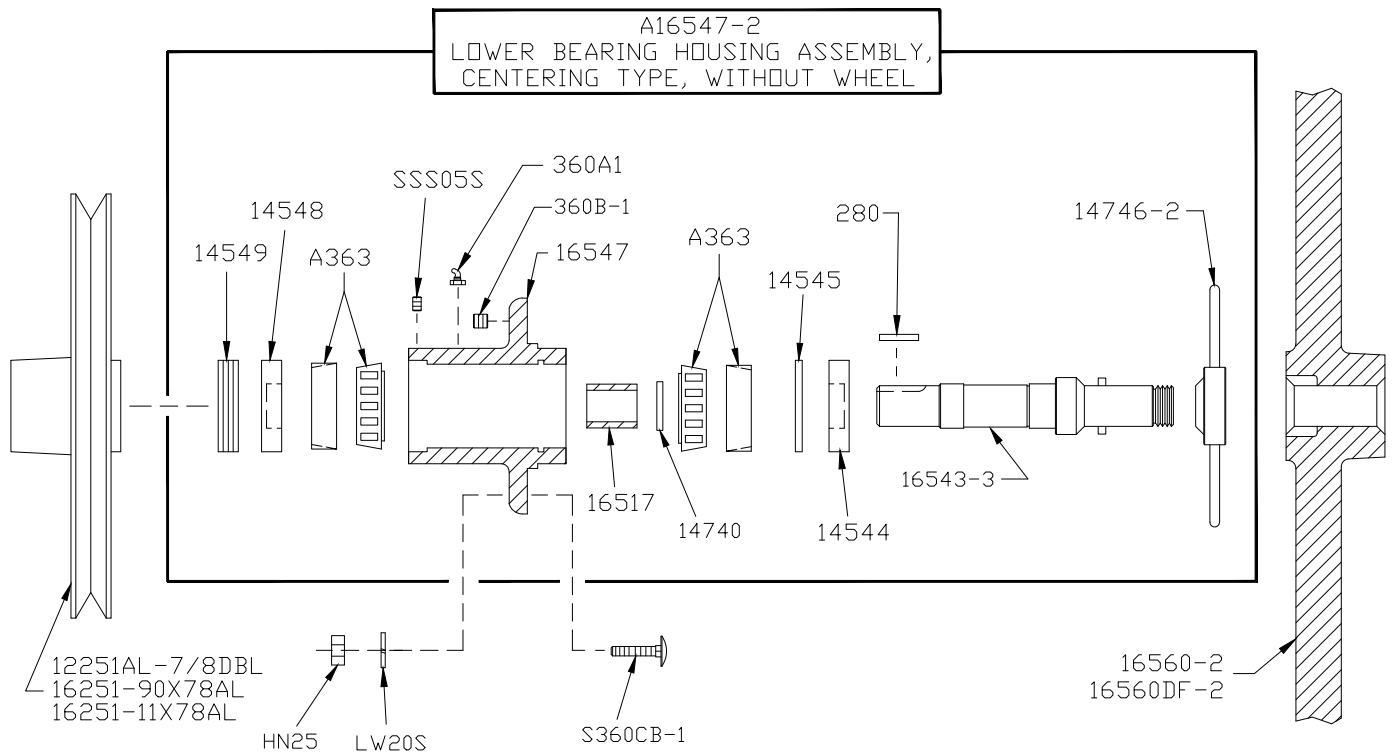

Item No.	Description
A16547-2	Lower bearing housing assembly, centering type, w/o wheel
A363	Lower bearing cup/cone assembly
HN25	Hex nut, 3/8-16, carbon-plated
LW20S	Lock washer, 3/8 heavy
S360CB-1	Carriage bolt, 3/8-16 x 1 1/4
SSS05S	Set screw, 10-24 x 3/8
12251AL-7/8DBL	Pulley, 9 x 7/8, upper double-V, aluminum
14544	Grease seal
14545	Retaining ring, internal
14548	Grease seal
14549	Lower bearing housing cap
14740	Retaining ring - external

Item No.	Description
14746-2	T-handle lock, removable lower wheel
16251-11X78AL	Pulley, 11.4 x 7/8 aluminum
16251-90X78AL	Pulley, 9 x 7/8 aluminum
16517	Inner race spacer
16543-3	Lower shaft, centering, removable wheel
16547	Lower bearing housing
16560-2	Lower removable wheel, 16", centering type
16560DF-2	Lower removable wheel, 16", double flange, centering type
280	Lower shaft motor key
360A1	Grease fitting - angled
360B-1	Set screw, 1/2-13, SS

REMOVAL and INSTALLATION for Self-Centering Lower Removable Wheels

*ALWAYS Turn Off, Unplug Machine From Power Source and Perform Lockout/Tagout Procedure to the Machine **BEFORE** Cleaning or Servicing.*

Follow disassembly procedures in the Cleaning Section of the Operating and Service Manual.

Removal of the Lower Wheel will be the last procedure.

REMOVAL

Loosen Item No. 14746-2, T-Handle Lock and Remove from lower shaft.

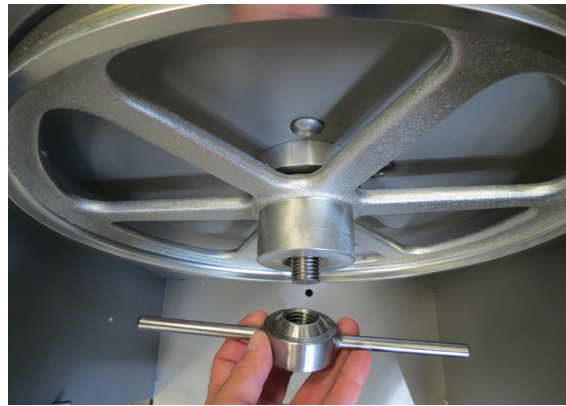

Using both hands @ 3 and 9 o'clock positions, Pull wheel towards you with an even smooth motion.

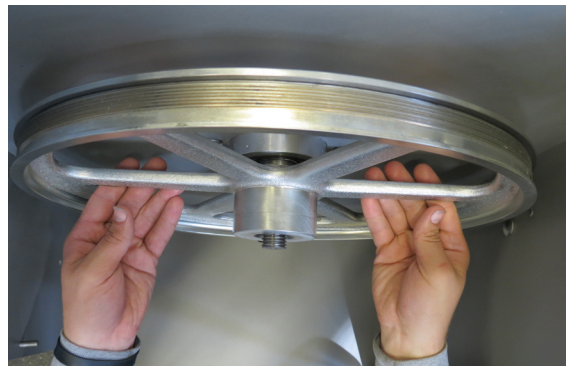

INSTALLATION

There is an anti-rotation pin located on the lower shaft, there is an anti-rotation groove located on the back side of the lower wheel.

Align and engage the groove of the lower wheel and the anti-rotation pin as the wheel is being installed.

Install T-handle Lock onto Lower Shaft, Hand Tighten SECURELY



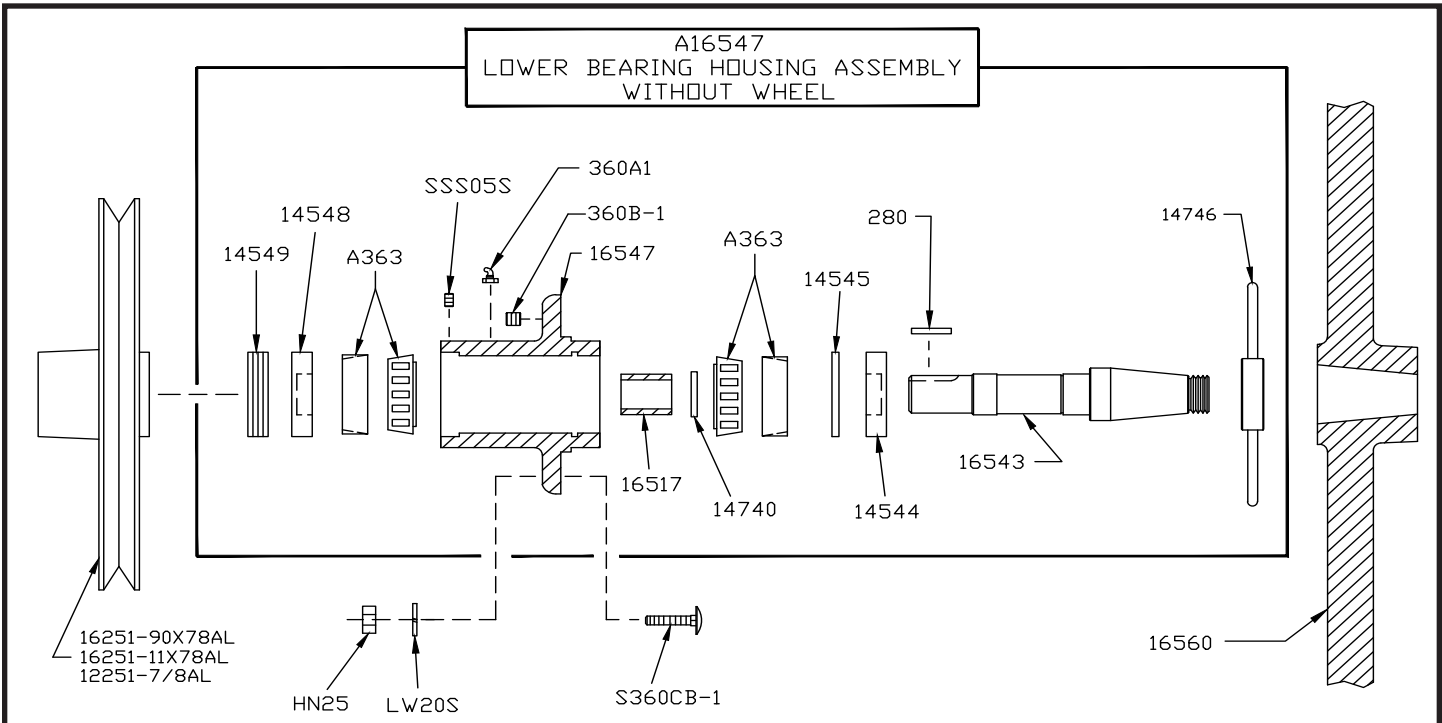

Item No.	Description	Item No.	Description
A16547	Lower bearing housing assembly, w/o wheel	14740	Retaining ring - external
A363	Lower bearing cup/cone assembly	14746	T-handle lock, removable lower wheel
HN25	Hex nut, 3/8-16, carbon-plated	16251-11X78AL	Pulley, 11.4 x 7/8 aluminum
LW20S	Lock washer, 3/8 heavy	16251-90X78AL	Pulley, 9 x 7/8 aluminum
S360CB-1	Carriage bolt, 3/8-16 x 1 1/4	16517	Inner race spacer
SSS05S	Set screw, 10-24 x 3/8	16543	Lower shaft, removable wheel
12251AL-7/8DBL	Pulley, 9 x 7/8 double-V	16547	Lower bearing housing
14544	Grease seal	16560	Lower removable wheel, 16", 6 spoke
14545	Retaining ring, internal	280	Lower shaft motor key
14548	Grease seal	360A1	Grease fitting - angled
14549	Lower bearing housing cap	360B-1	Set screw, 1/2-13, SS

Item No. 16543 - Lower Shaft for Removable Wheel

The Model 3334 Lower Removable Wheel has been revised to include a keyway in the bore. Also an anti-rotation pin is now pressed into the lower shaft to prevent any inadvertent "spinning" of the wheel on the shaft.

NOTE - If the saw in which a new shaft is to be installed has a groove (keyway) in the bore of the lower wheel, press the taper pin (provided "loose") into the hole in the side of the shaft (see sketch).

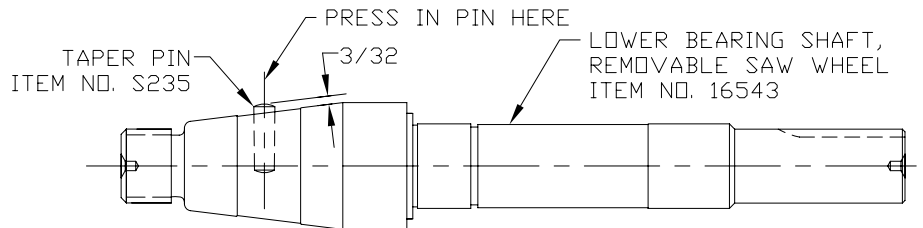

If there is no groove (keyway) in the bore of the lower wheel, discard the taper pin and use the shaft without the pin.

LOWER REMOVABLE WHEEL INSTALLATION AND REMOVAL INSTRUCTIONS

*ALWAYS Turn Off, Unplug Machine From Power Source and Perform Lockout/Tagout Procedure to the Machine **BEFORE** Cleaning or Servicing.*

Follow disassembly procedures in the Cleaning Section of the Operating and Service Manual.

Removal of the Lower Wheel will be the last procedure.

REMOVAL

Loosen Item No. 14746, T-Handle Lock. **DO NOT REMOVE COMPLETELY FROM SHAFT.**

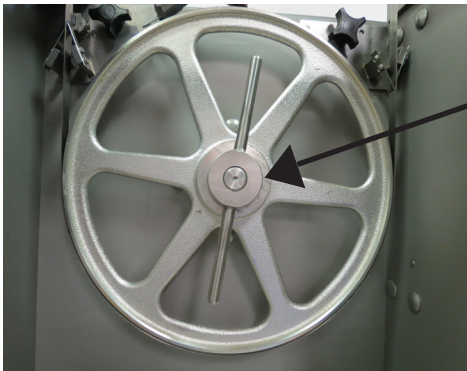

14746
T-Handle
Lock



T-Handle
Loosened

Using thumbs for leverage, pull wheel toward you with an even-smooth motion. Wheel is mounted in slip fit fashion on a tapered shaft. When the wheel is loose, complete removing T-Handle lock and wheel.



14746
T-Handle
Lock

INSTALLATION



There is an alignment pin on the lower shaft. And a mating alignment groove in the hub of the lower wheel. Align the two as the wheel is being installed on the tapered shaft.



**NOTE:
TO ENSURE PROPER SAW
WHEEL ALIGNMENT,
WHEEL MUST BE
REINSTALLED ON SAME
MACHINE IT WAS
REMOVED.**

Replace the
T-Handle Lock
**HAND TIGHTEN
ONLY**
Reassemble the machine.



A609AAW-16 SWITCH ASSEMBLY

Item No.	Description
A16226A	Green/red switch button assembly w/ springs
A609AAW-16	Switch assembly, 1 & 3 ph, less heater coils
H462-2	Guard for switch toggle
H462A	Guard assembly for switch toggle
HHS010S	Hex Head Screw, 10-32 x 3/8 SS
HHS070S	Hex Head Screw, 3/8-16 x 1 SS
HN10S	Hex Nut, 10-32 SS
HN20S	Hex Nut, 5/16-18 SS heavy
LW15S	Lock Washer, 5/16 SS regular
LW20S	Lock Washer, 3/8 SS
16296-2	Switch bracket, SS
150	Conduit, 1/2"
224	Conduit connector, 180°
226-28	Washer SS, 1 1/2 x 27/32
241BL	Wire, black, 12GA., CSA & UL
241WH	Wire, white, 12GA., CSA & UL
259	Anti-short bushing- 1/2"
340	Star lock washer
609AAW	Manual switch, size 0, 1 & 3 ph

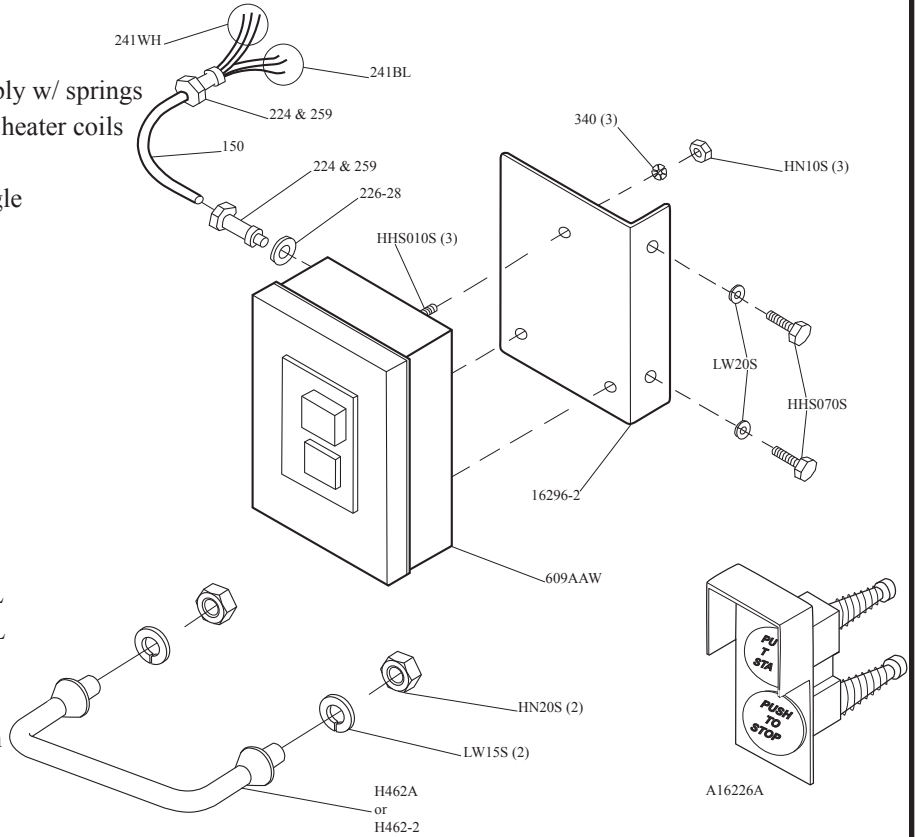

609AAW 3 Phase

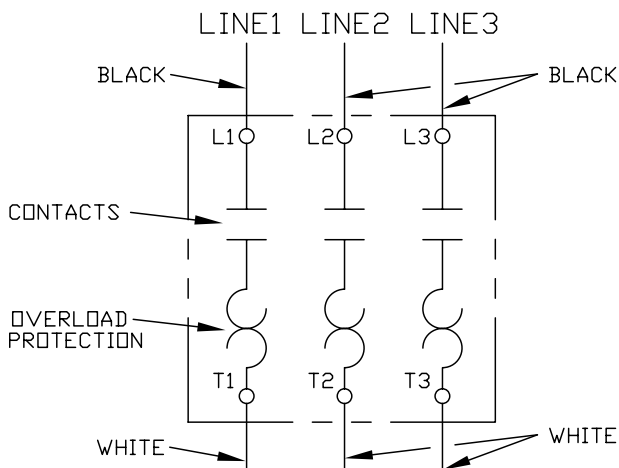

Wire Diagram for Baldor Motor Spec. No. 35M388S508 230V/1 Phase/50Hz Used with 609AAW Starter, A-B

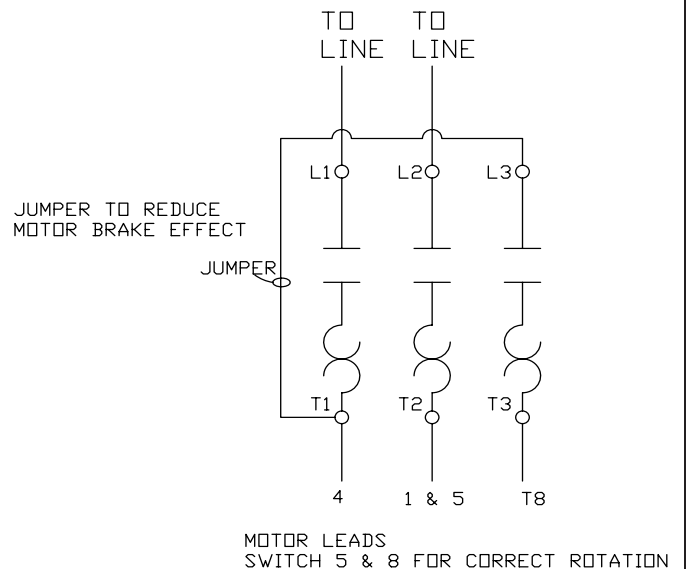

WATERTIGHT MAGNETIC SWITCH ASSEMBLIES

(AEG)

INCLUDES MOUNTING BRACKET AND WIRES

Item No.	Description	Item No.	Description
A22616EE-514	BAEG/MS-PB/05-C8 2HP 208-220-50/60-3	A22616EE-530	BAEG/MS-PB/05-F3.2 2HP 550/575-3
A22616EE-516	BAEG/MS-PB/05-E4.7 2HP 440/460-3	A22616EE-534	BAEG/MS-PB/05-E6.3 3HP 440/460-60-3
A22616EE-518	BAEG/MS-PB/05-D4.7 1.5-2HP 380/415-50-3	A22616EE-536	BAEG/MS-PB/05-D8 3HP 380-60-3
A22616EE-522	BAEG/MS-PB/05-C14 3HP 220-230-50/60-3	A22616EE-538	BAEG/PC-PB/05-F4.7 3HP 550-60-3
A22616EE-5221	BAEG/MS-PB/05-CS14 1.5HP 208/230-50/60-1	A22616EE-540	BAEG/MS-PB/C18 5HP 220-60-3
A22616EE-5241	BAEG/MS-PB/A26 1.5-2HP 104/115-60-1	A22616EE-544	BAEG/MS-PB/05-E8 5HP 440/460-60-3
A22616EE-5261	BAEG/MS-PB/CS16 2HP 230-60-1	A22616EE-546	BAEG/MS-PB/05-D14 5HP 380/415-50-3
		A22616EE-548	BAEG/MS-PB/05-F8 5HP 550/575-60-3

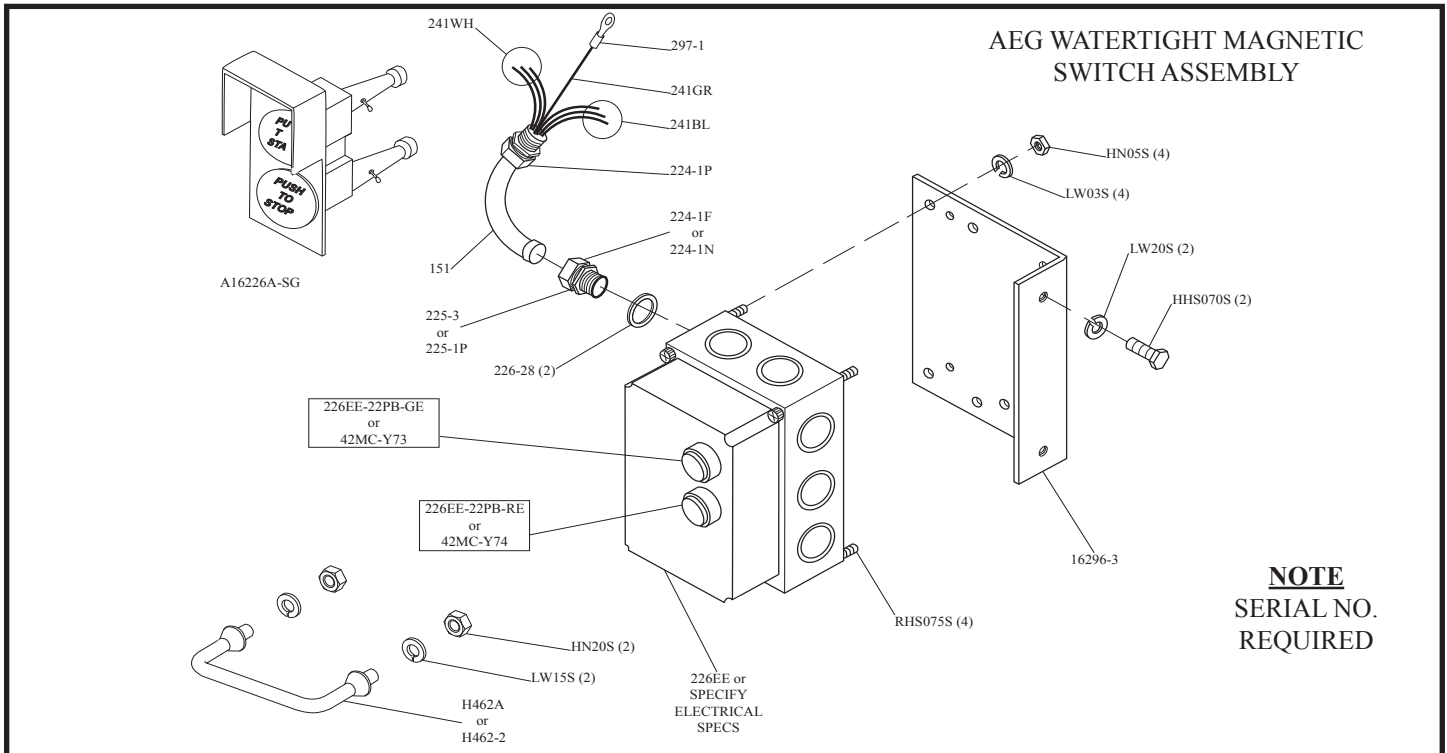

NOTE
SERIAL NO.
REQUIRED

Item No.	Description	Item No.	Description
A16226A-SG	Green/red switch button assembly	226EE-OL08.5L	Overload, B18K-L, 5.5-8.5A
H462-2	Guard for switch toggle	226EE-OL08L	Overload, B05-L, 5.5-8.5A
H462A	Guard assembly for switch toggle	226EE-OL12M	Overload, B18K-M, 8-12A
HHS070S	Hex head screw, 3/8 -16 x 1 SS	226EE-OL14NN	Overload, B05-NN, 10-14A
HN05S	Hex nut, 8-32 SS	226EE-OL180	Overload, B18K-O, 14.5-18A
HN20S	Hex nut, 5/16-18 SS	226EE-OL26ON	Overload, B18K-ON, 21-26A
LW03S	Lock washer, #8 SS	226EE-514	BAEG/MS-PB/05-C8 2HP 220-50/60-3
LW15S	Lock washer, 5/16 SS	226EE-516	BAEG/MS-PB/05-E4.7 2HP 440-60-3
LW20S	Lock washer, 3/8" SS	226EE-518	BAEG/MS-PB/05-D4.7 2HP 380-50-3
RHS075S	Round head screw, 8-32 x 3/4 SS	226EE-522	BAEG/MS-PB/05-C14 3HP 230-50/60-3
151	Watertight conduit	226EE-5241	BAEG/MS-PB/A26 2HP 120-60-1
16296-3	Switch bracket, SS	226EE-5261	BAEG/MS-PB/CS16 2HP 230-60-1
224-1F	Conduit ferrule for watertight connector	226EE-530	BAEG/MS-PB/05-F3.2 2HP 550-60-3
224-1N	Conduit nut for watertight connector	226EE-534	BAEG/MS-PB/05-E6.3 3HP 440-60-3
224-1P	Conduit connector, WT, 180°	226EE-536	BAEG/MS-PB/05-D8 3HP 380-50-3
226EE-ENCL-PB22	Enclosure w/ pushbutton, 22mm holes	226EE-538	BAEG/PC-PB/05-F4.7 3HP 550-60-3
226EE-ENCL-PB30	Enclosure w/ pushbutton, 30mm holes	226EE-540	BAEG/MS-PB/C18 5HP 220-60-3
226EE-AO	Contactors, LS05.10-AO, 120V	226EE-544	BAEG/MS-PB/05-E8 5HP 440-60-3
226EE-AO11K	Contactors, LS11K.11S-AO, 120V	226EE-546	BAEG/MS-PB/D14 5HP 380-415-50-3
226EE-CO	Contactors, LS05.10-CO, 208-230V	226EE-548	BAEG/MS-PB/05-F8 5HP 550-60-3
226EE-CO11K	Contactors, LS11K.11S-CO, 208-230V	226-28	Washer, 1 1/2 x 27/32 SS
226EE-DO	Contactors, LS05.10-DO, 380-415V	241BL	Wire, black 12 GA., CSA & UL
226EE-EO	Contactors, LS05.10-EO 440-480V	241GR	Wire, green 12 GA., CSA & UL
226EE-FO	Contactors, LS05.10-FO 550V	241WH	Wire, white 12 GA., CSA & UL
226EE-OL01.9G	Overload, B18K-G, 1.3-1.9A	297-1	Wire terminal eyelet for 12 GA. wire
226EE-OL4I	Overload, B18K-I, 2.5-4A	42MC-Y73	Green start pushbutton assembly, 30mm
226EE-OL04.7JN	Overload, B05-JN, 3-4.7A	42MC-Y74	Red stop pushbutton assembly, 30mm
H281EE-51	Overload, B18K-K, 4-6.3A	226EE-22PB-GE	Green start pushbutton assembly, 22mm
226EE-OL06.3K	Overload, B05-K, 4-6.3A	226EE-22PB-RE	Red stop pushbutton assembly, 22mm

-115 VOLT WITH 6 LEADS-

SCHEMATIC USING 3-POLE AEG WATERTIGHT SWITCH WITH JUMPER
TO ELIMINATE BREAKING EFFECT OF MOTOR AFTER STOP IS ENGAGED.
2HP & 3HP/60HZ/1PH BALDOR MOTOR WITH 6 MOTOR LEADS
WIRED FOR 115 VOLTS

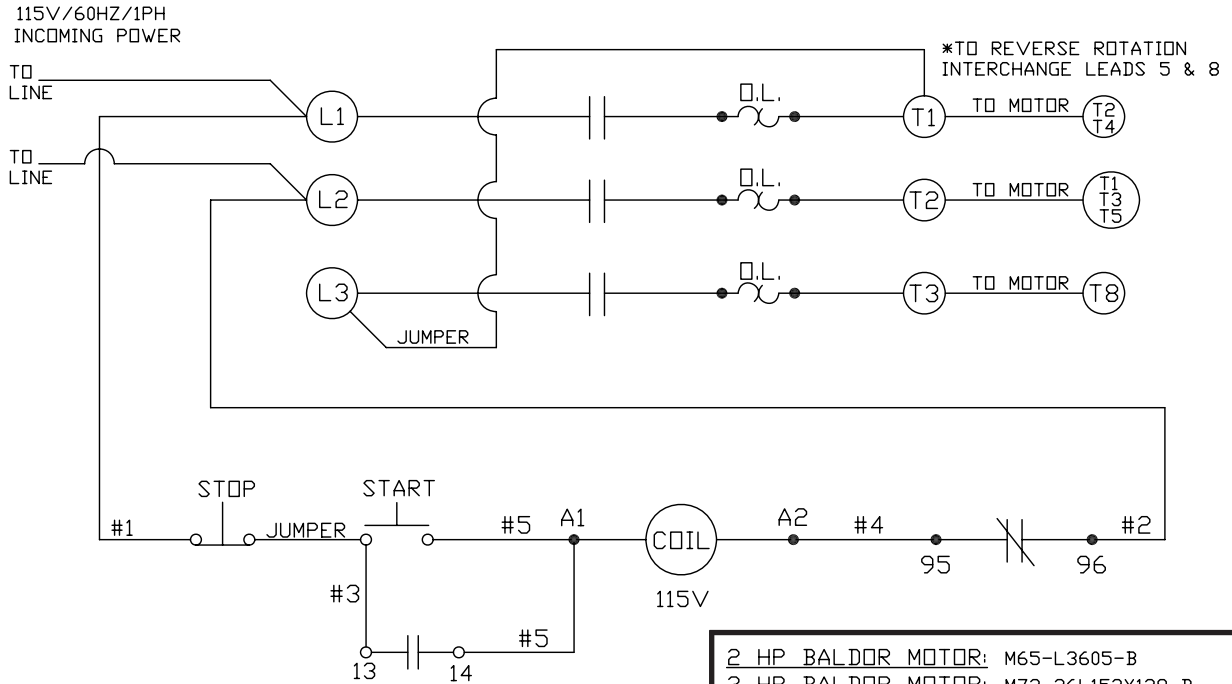

-115 VOLT WITH 6 LEADS-

SCHEMATIC USING 3-POLE AEG WATERTIGHT SWITCH WITH JUMPER
TO ELIMINATE BREAKING EFFECT OF MOTOR AFTER STOP IS ENGAGED.
2HP/50HZ/1PH BALDOR MOTOR WITH 6 MOTOR LEADS, WIRED 115 VOLTS

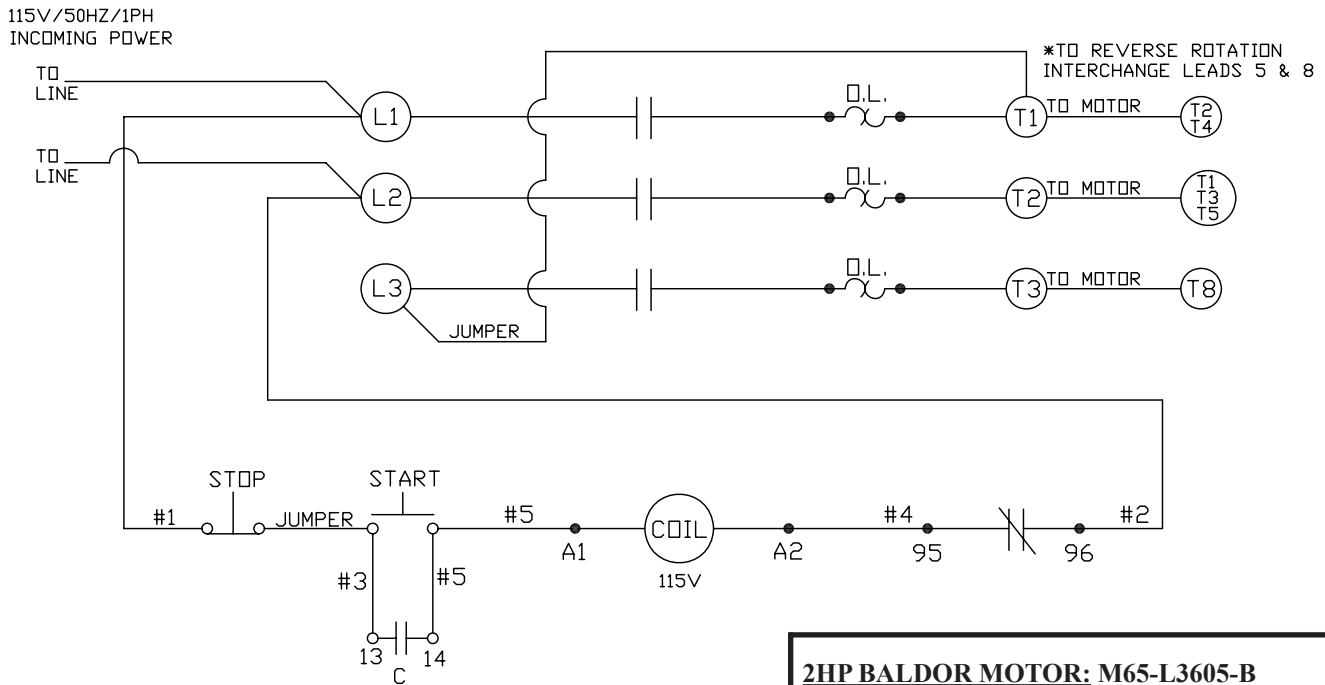

-115 VOLT WITH 7 LEADS-

SCHEMATIC USING 3-POLE AEG WATERTIGHT SWITCH WITH JUMPER TO ELIMINATE BREAKING EFFECT OF MOTOR AFTER STOP IS ENGAGED. 2HP/60HZ/1PH BALDOR MOTOR WITH 7 MOTOR LEADS, WIRED FOR 115 VOLTS

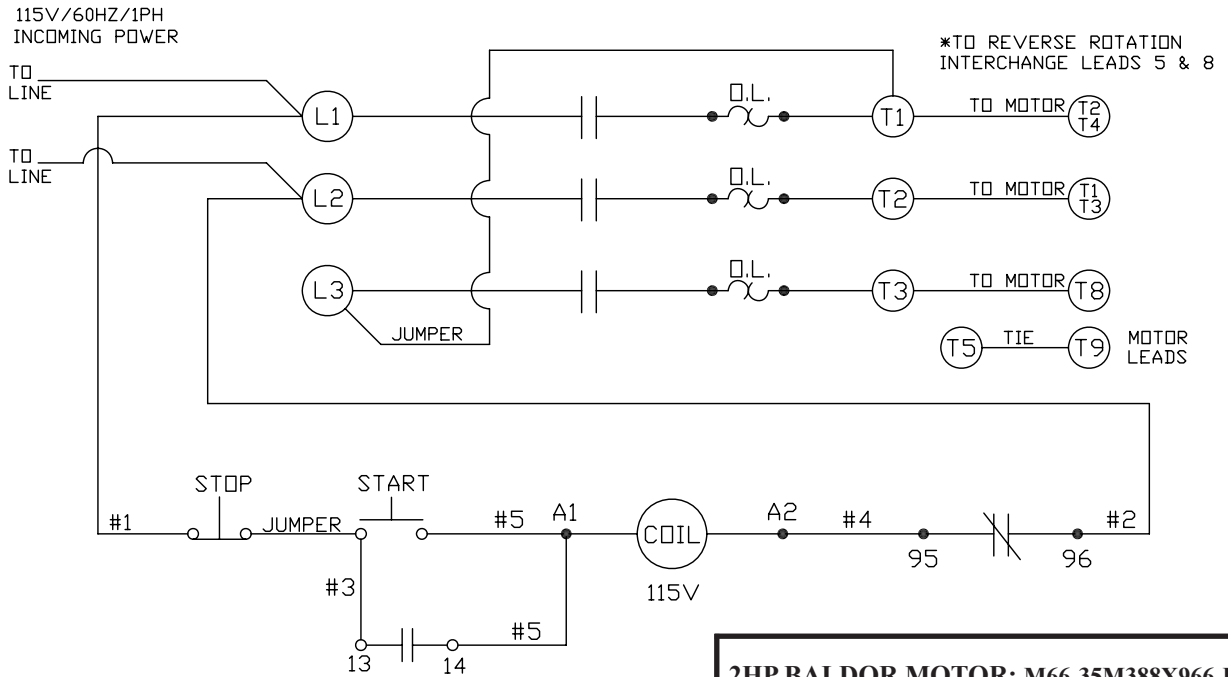

-230 VOLT WITH 6 LEADS-

SCHEMATIC USING 3-POLE AEG WATERTIGHT SWITCH WITH JUMPER TO ELIMINATE BREAKING EFFECT OF MOTOR AFTER STOP IS ENGAGED. 2HP & 3HP/60HZ/1PH BALDOR MOTOR WITH 6 MOTOR LEADS WIRED FOR 230 VOLTS

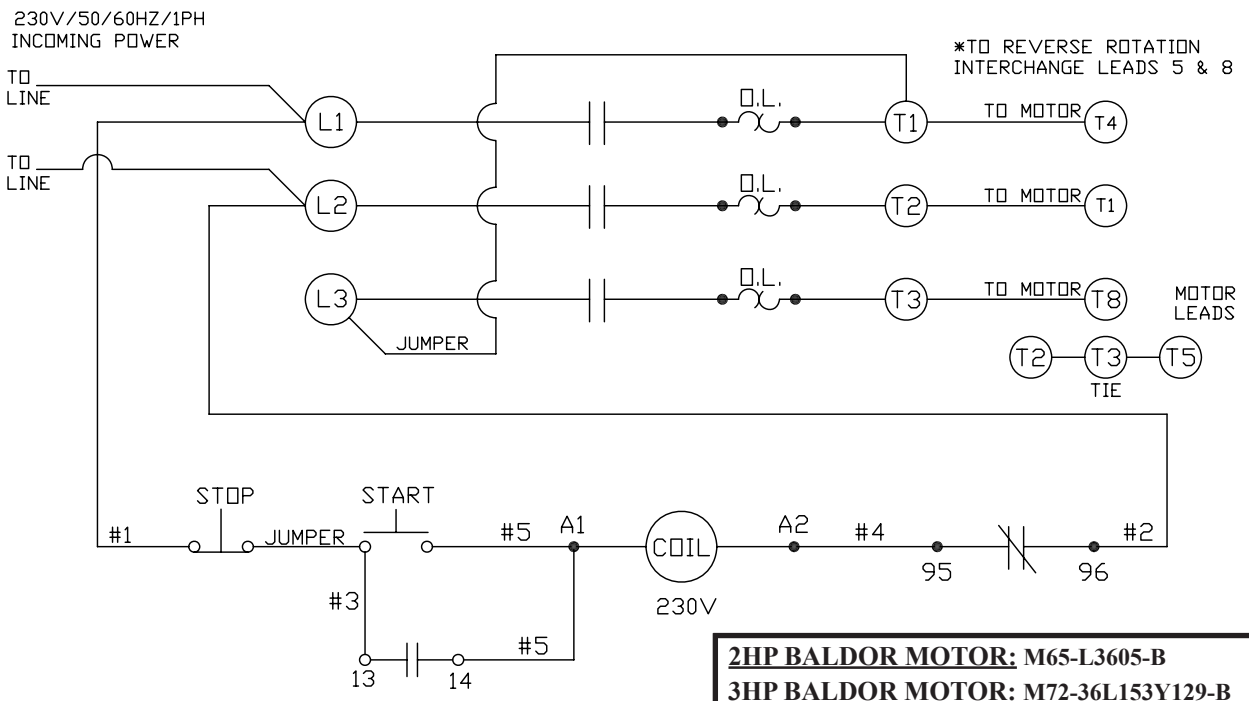

-230 VOLT WITH 6 LEADS-

SCHEMATIC USING 3-POLE AEG WATERTIGHT SWITCH WITH JUMPER TO ELIMINATE BREAKING EFFECT OF MOTOR AFTER STOP IS ENGAGED. 2HP/50HZ/1PH BALDOR MOTOR WITH 6 MOTOR LEADS, WIRED FOR 230 VOLTS

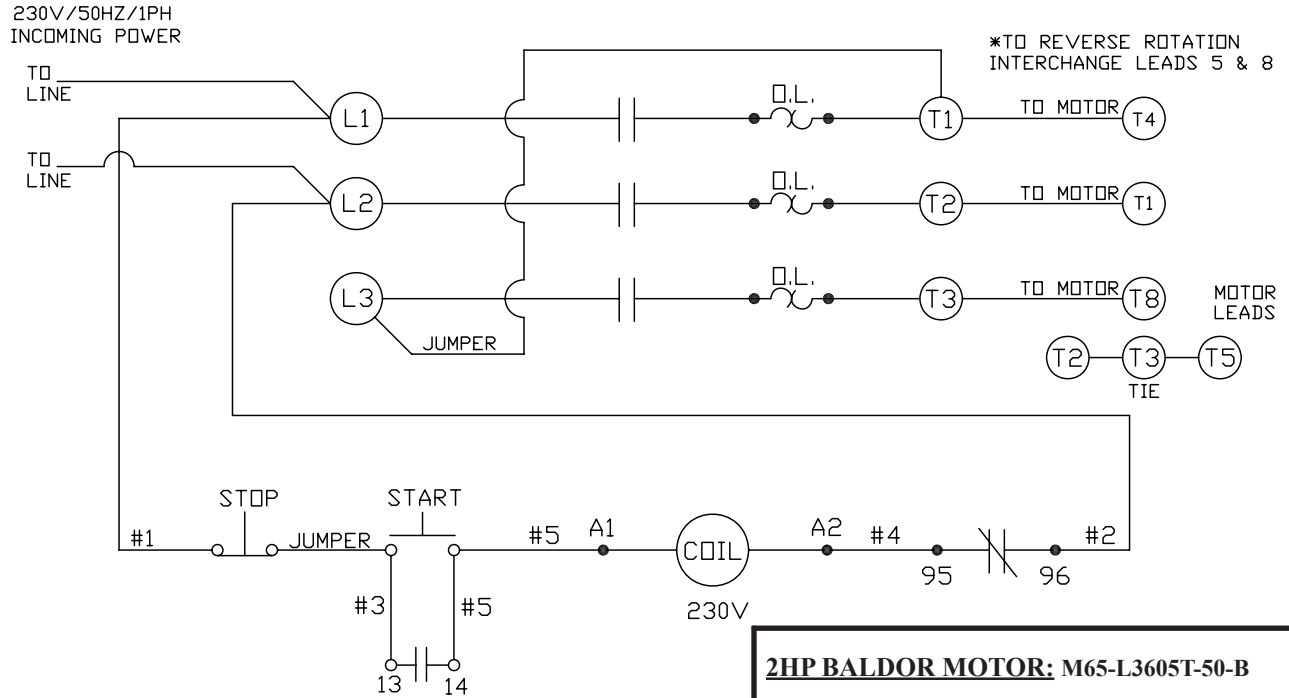

-230 VOLT WITH 7 LEADS-

SCHEMATIC USING 3-POLE AEG WATERTIGHT SWITCH WITH JUMPER TO ELIMINATE BREAKING EFFECT OF MOTOR AFTER STOP IS ENGAGED. 2HP/60HZ/1PH BALDOR MOTOR WITH 7 MOTOR LEADS, WIRED FOR 230 VOLTS

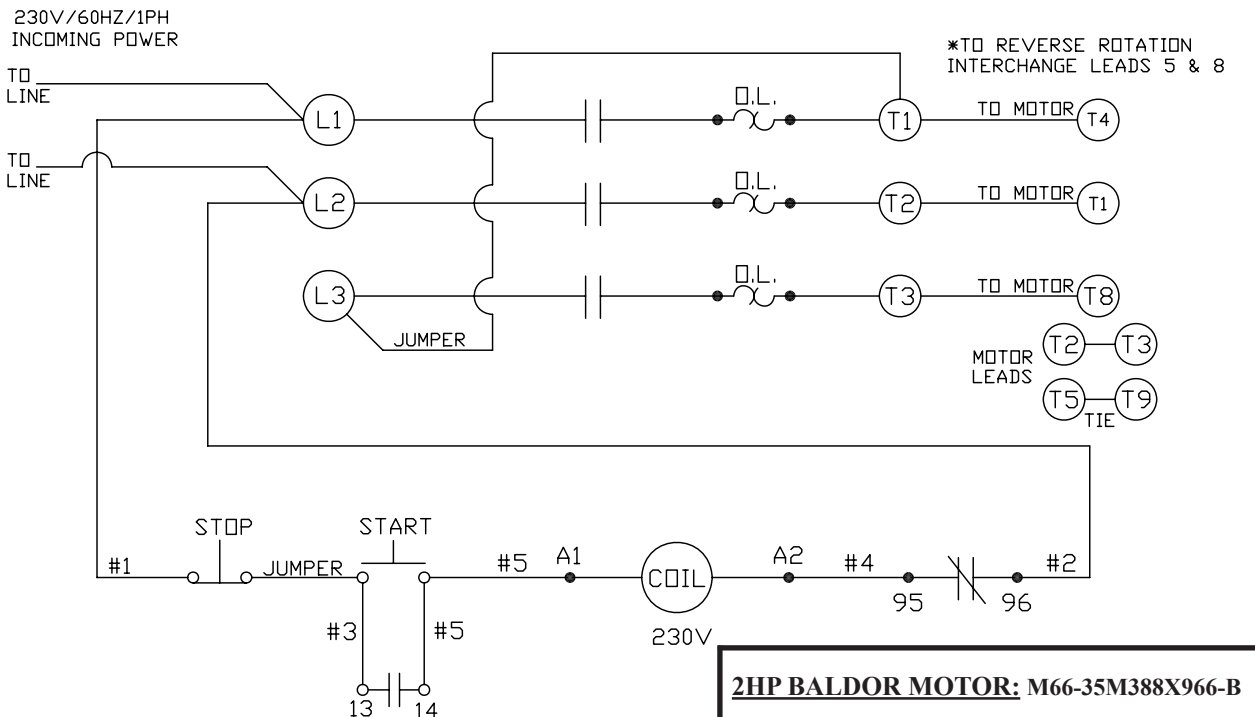

-208-230 VOLT WITH 9 LEADS-
 SCHEMATIC USING 3-POLE AEG WATERTIGHT SWITCH
 2HP/50/60HZ/3PH WEG MOTOR WITH 9 MOTOR LEADS, WIRED FOR 208-230 VOLTS

208-230V/50/60HZ/3PH
 INCOMING POWER

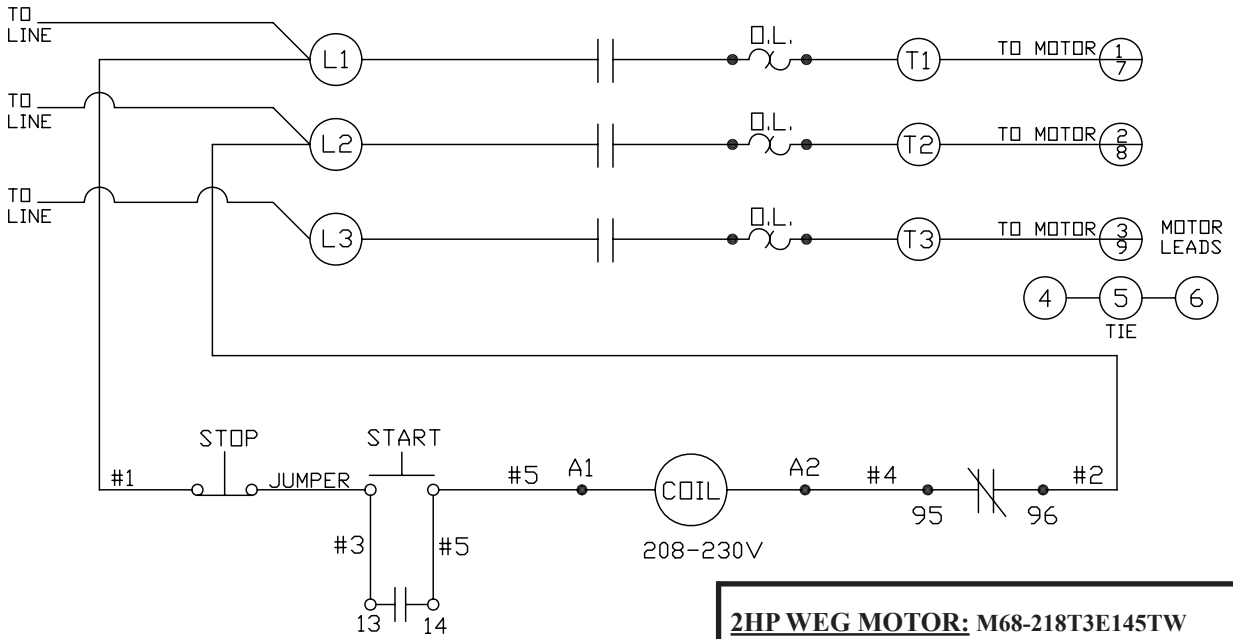

2HP WEG MOTOR: M68-218T3E145TW

-208/220/230 VOLT 3 PHASE WITH 9 LEADS-
 SCHEMATIC USING 3-POLE AEG WATERTIGHT SWITCH
 2HP/60HZ/3PH BALDOR MOTOR WITH 9 MOTOR LEADS (OR)
 2HP & 3HP/50/60HZ/3PH US ELECTRIC/NIDEC MOTOR CORP WITH 9 MOTOR LEADS,
 WIRED FOR 208-230 VOLTS

208-230V/50/60HZ/3PH
 INCOMING POWER

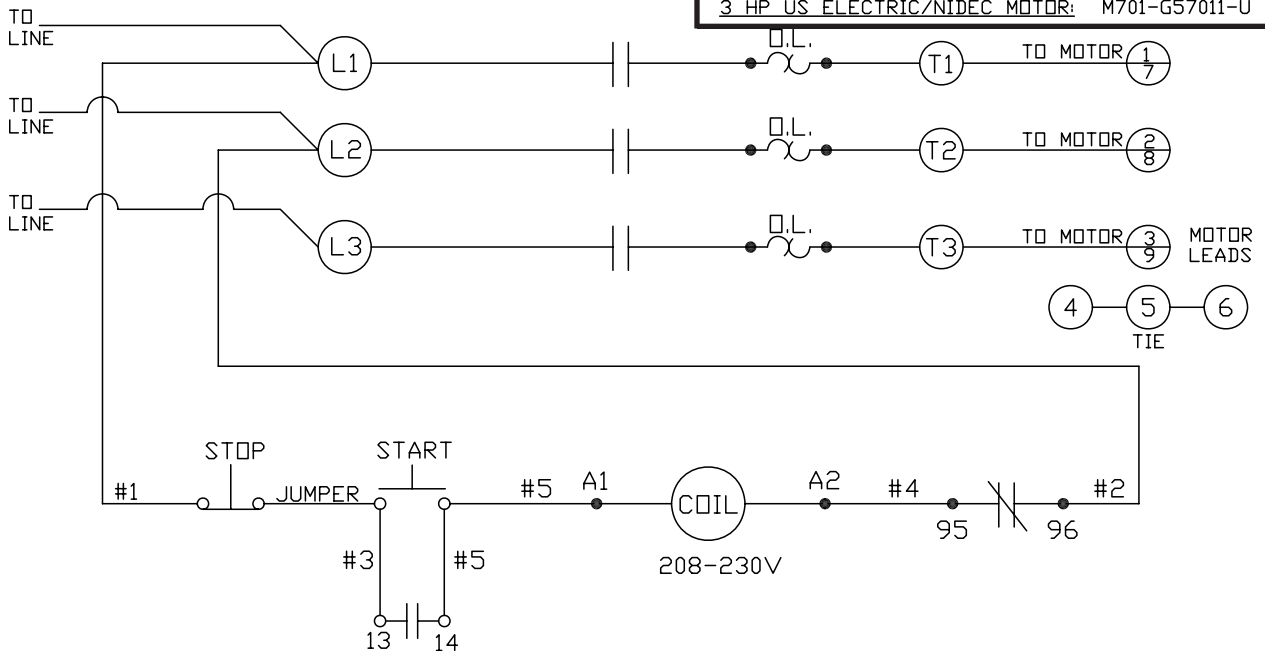

2 HP BALDOR MOTOR: M68-M3558T-B
2 HP US ELECTRIC/NIDEC MOTOR: M55-G54313-U
3 HP US ELECTRIC/NIDEC MOTOR: M701-G57011-U

-208/220/230 VOLT 3 PHASE WITH 9 LEADS-
 SCHEMATIC USING 3-POLE AEG W.T. SWITCH
 3HP/60HZ/3PH US ELECTRIC/EMERSON MOTOR WITH 9 MOTOR LEADS
 WIRED FOR 208/220/230 VOLTS

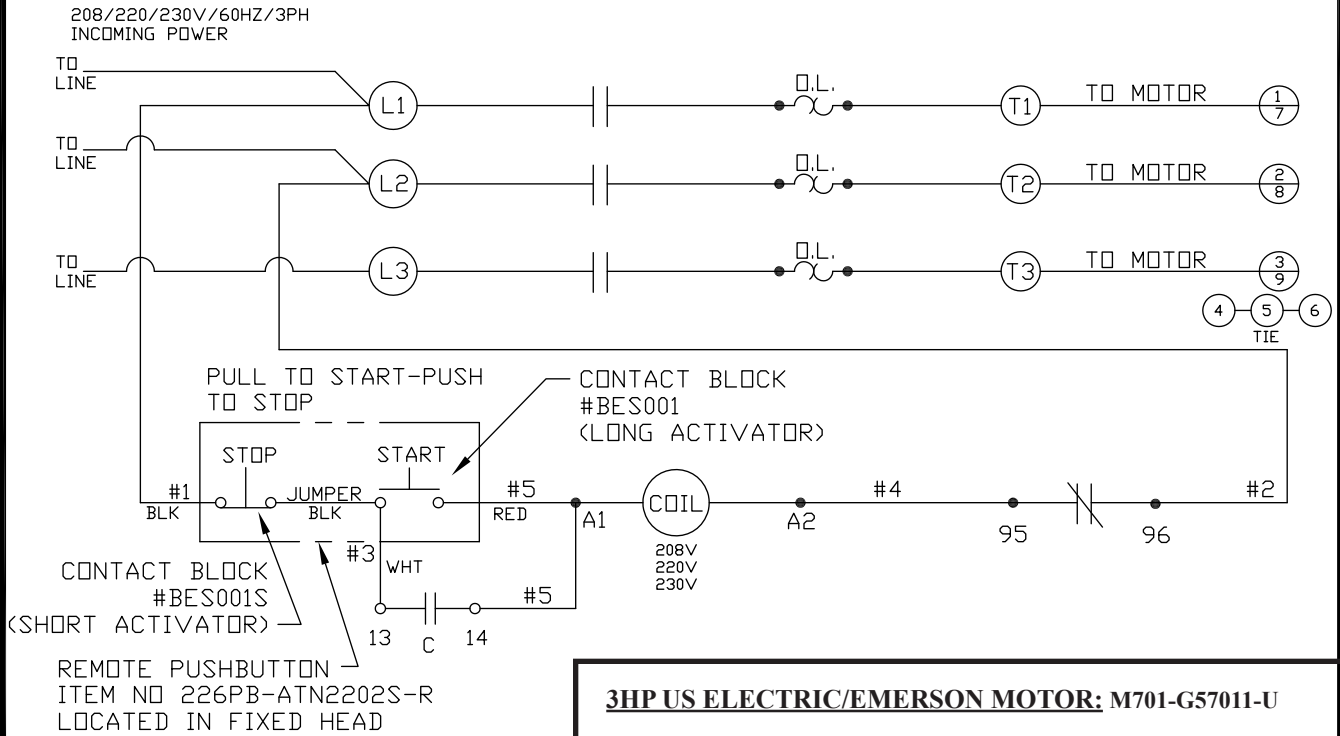

-220 VOLT WITH 12 LEADS-
 SCHEMATIC USING 3-POLE AEG WATERTIGHT SWITCH
 2HP/50HZ/3PH BALDOR MOTOR WITH 12 MOTOR LEADS, WIRED FOR 220 VOLTS

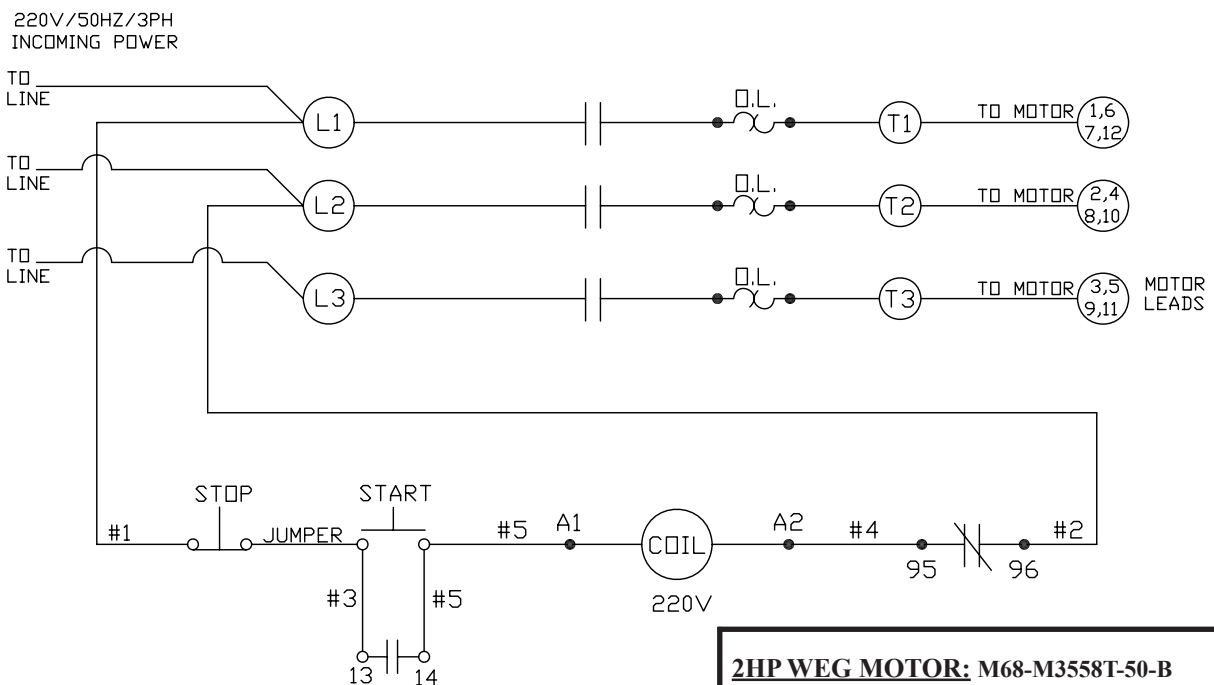

-380-460 VOLT WITH 9 LEADS-
SCHEMATIC USING 3-POLE AEG WATERTIGHT SWITCH

2HP/50/60HZ/3PH WEG MOTOR WITH 9 MOTOR LEADS, WIRED FOR 380-460 VOLTS

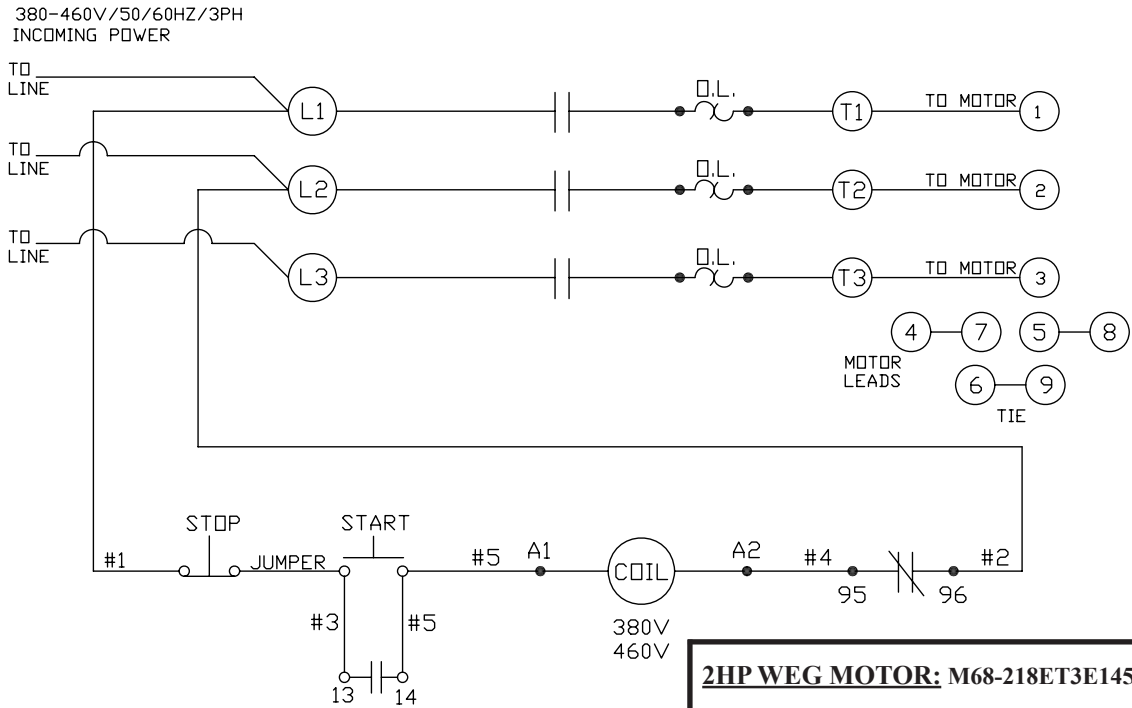

-380 VOLT WITH 12 LEADS-
SCHEMATIC USING 3-POLE AEG WATERTIGHT SWITCH
2HP/50HZ/3PH BALDOR MOTOR WITH 12 MOTOR LEADS, WIRED FOR 380 VOLTS

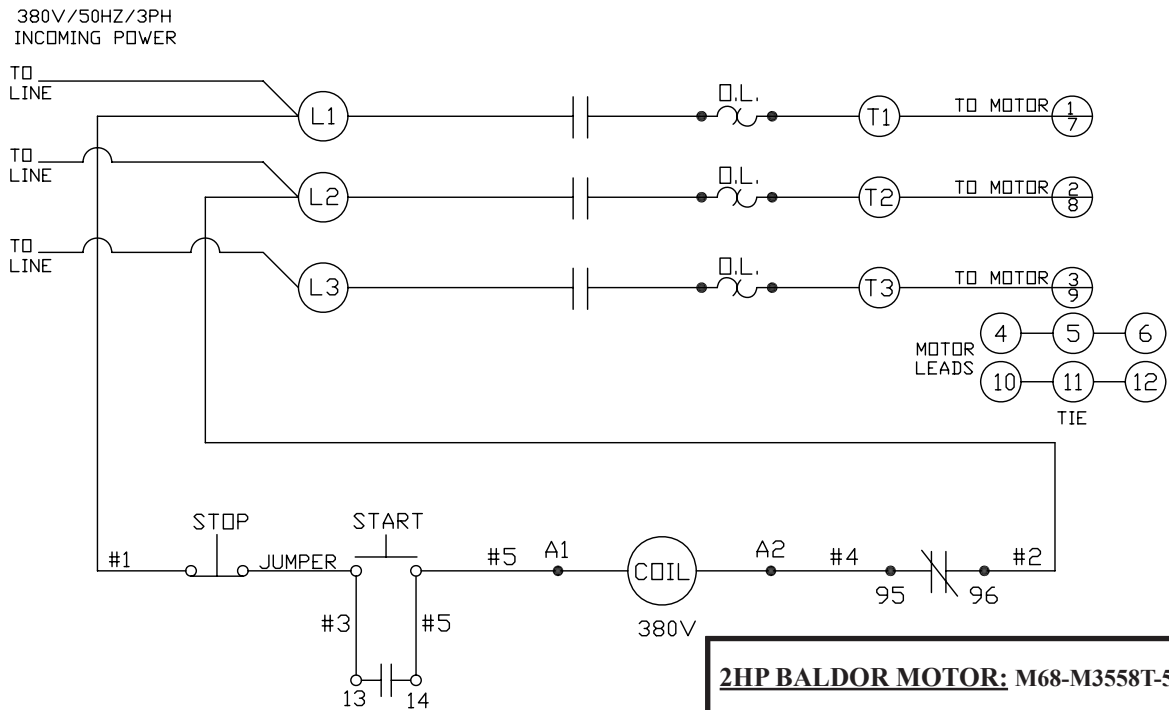

-440-460 VOLT 3 PHASE WITH 9 LEADS-

SCHEMATIC USING 3-POLE AEG WATERTIGHT SWITCH
 2HP/60HZ/3PH BALDOR MOTOR WITH 9 MOTOR LEADS (OR)
 2HP & 3HP/50/60HZ/3PH US ELECTRIC/NIDEC MOTOR CORP WITH 9 MOTOR LEADS,
 WIRED FOR 440-460 VOLTS

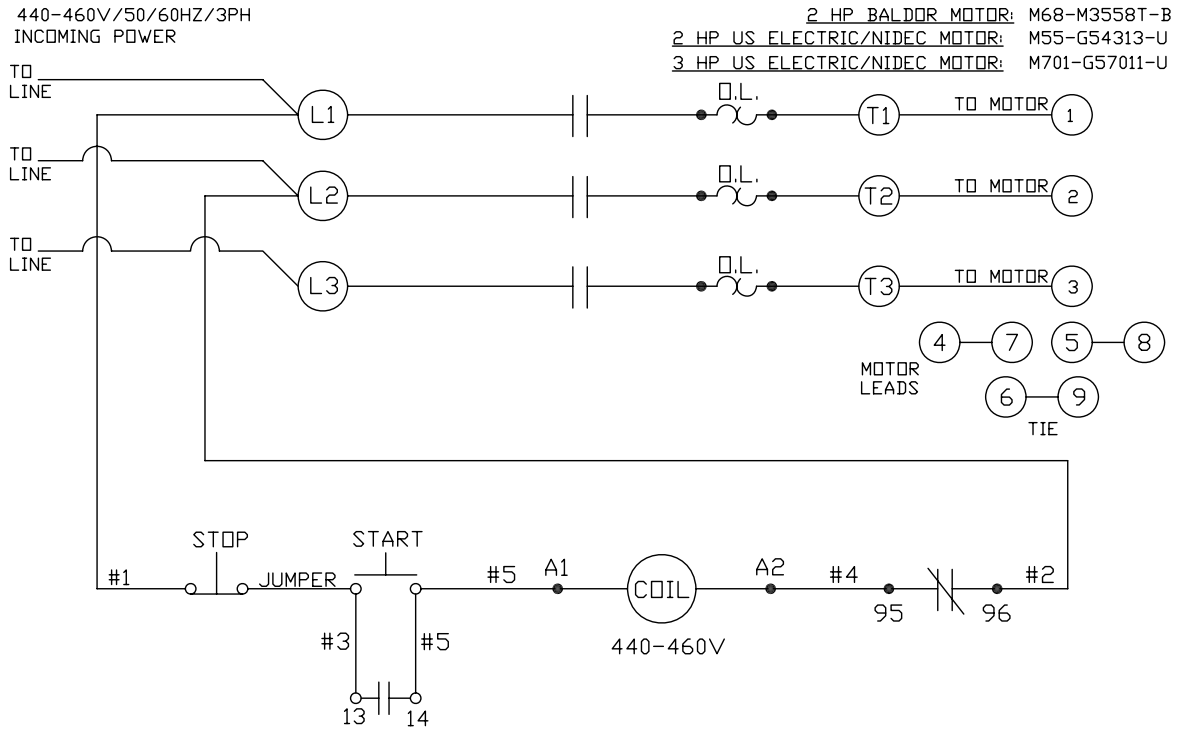

-440 VOLT WITH 12 LEADS-

SCHEMATIC USING 3-POLE AEG WATERTIGHT SWITCH
 2HP/50HZ/3PH BALDOR MOTOR WITH 12 MOTOR LEADS, WIRED FOR 440 VOLTS

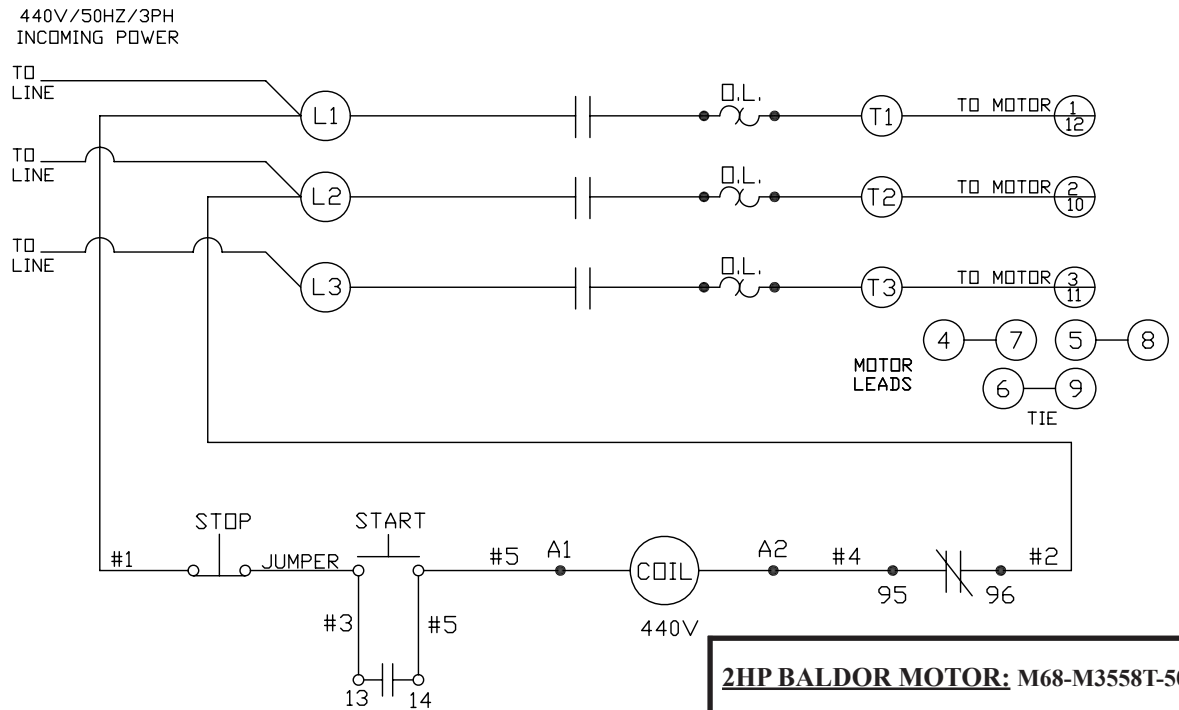

MODEL 3334 PART NUMBERS AND DESCRIPTIONS

MODEL & SERIAL NO. REQUIRED WHEN ORDERING PARTS

Item No.	Description	Item No.	Description
AN15S	Acorn nut, 1/4-20, SS	S19	Ratchet base, SS
FW06S	Flat washer, 1/4, SS	S200B1	Stop stud, guide bar & carriage stop
FW07S	Flat washer, 3/8, SS	S229	Wheel cleaner arm spring, SS
FW08S	Flat washer, 3/8 ID x 1" OD, SS	S235	Taper pin, 4 x 3/4, SS
FW10S	Flat washer, 5/16, SS	S239-B40	Base foot, welded, SS
FW15S	Flat washer, 1/2, SS	S239-B41	Adjustable leg bolt, SS
HHS003S	Hex head screw, 8-32 x 1/4, SS	S240	Ratchet trigger spring, SS
HHS005S	Hex head screw, 8-32 x 1/2, SS	S242R	Base door lock, right
HHS010S	Hex head screw, 10-32 x 3/8, SS	S244	Wheel cleaner arm stud
HHS015S	Hex head screw, 10-32 x 7/8, SS	S249	Base door lock handle
HHS020S	Hex head screw, 1/4-20 x 3/8, SS	S252X	Shaft lock nut, SS
HHS025S	Hex head screw, 1/4-20 x 1/2, SS	S253	Upper wheel aligning screw, SS
HHS035S	Hex head screw, 1/4-20 x 5/8, SS	S262	Meat gauge release handle, SS
HHS040S	Hex head screw, 1/4-20 x 3/4, SS	S264-1	Meat gauge release hand wheel
HHS049NL	Hex head screw, 5/16-18 x 1/2, Nylon	S265	Meat gauge release spring, SS
HHS050S	Hex head screw, 5/16-18 x 5/8, SS	S268	Stationary bar headless screw, SS
HHS055S	Hex head screw, 5/16-18 x 3/4, SS	S270	Meat gauge release pin w/ hole, SS
HHS060S	Hex head screw, 5/16-18 x 1, SS	S295	Wheel cleaner arm, SS
HHS070S	Hex head screw, 3/8-16 x 1, SS	S325	Wheel cleaner arm washer, SS
HHS075S	Hex head screw, 3/8-16 x 1 1/4, SS	S360CB-1	Carriage bolt 3/8-16 x 1 1/4, SS
HN05S	Hex nut, 8-32, SS	S415D	Stainless stationary bar
HN10S	Hex nut, 10-32, SS	S416	Platter locator weld pin, SS
HN15S	Hex nut, 1/4-20, SS	SSS05S	Set screw, cup, 10-24 x 3/8, SS
HN20S	Hex nut, 5/16-18, SS	SSS15S	Set screw, 5/16-18 x 5/16 cup point, SS
HN25	Hex nut, 3/8-16, plated	SSS20	Set screw, 3/8-16 x 3/8, SS knurled cup point
HN25S	Hex nut, 3/8-16, SS	10-1	Ratchet arm
HN30S	Hex nut, 3/8-16, light jam, SS	111AL	Tension spring pin, Al
HN35S	Hex nut, 3/8-16, heavy jam, SS	112-212	Waved washer, 2 1/64 I.D. 5/8 O.D.
LH663	Left hand saw guard	116-22	Saw guide bar, 22 inch
LW05S	Lock washer, #10, SS	119FSC	Saw guide, fish
LW10S	Lock washer, 1/4, SS	12251AL	Upper V-belt pulley 9 x 1, aluminum
LW15S	Lock washer, 5/16, SS	12251AL-DBL	Upper pulley, double-V, 9 x 1, aluminum
LW20S	Lock washer, 3/8, regular, SS	12251AL-7/8DBL	Upper pulley, double-V, 9 x 7/8, aluminum
M55-G54313-U	Motor, 2HP 208-220/440-50/60-3, Open	131	Saw cleaner
M65-L3605-B	Motor, 2HP 115/230-60-1, TE	14544	Grease seal, 1 1/2" I.D.
M66-35M388X966-B	Motor, 2HP 115/230-60-1 Open	14545	Retaining ring, internal
M68-M3558T-B	Motor, 2HP 208-230/440-60-3, TE	14548	Grease seal
M701-G57011-U	Motor, 3HP 220/440-50/60-3 TE	14549	Lower bearing housing cap
M72-131533-L	Motor, 3HP 115/208-230-60-1 TEFC	14668	Motor pulley, double-V, 6 x 1 1/8
RHS10S	Round head screw, 10-32 x 3/4, SS	14669	Motor pulley, double-V, 5 x 1 1/8
RHS20S	Round head screw, 10-32 x 1 1/8, SS	16003-6	Lower wheel 16", 6 spoke
RHS25S	Round head screw, 1/4-20 x 3/4, SS	16003DF-6	Lower double flange wheel 16", 6 spoke
RHS30S	Round head screw, 1/4-20 x 7/8, SS	16003U-6	Upper wheel 16", 6 spoke
S1007	Channel bracket, SS (3334-4003 only)	16003UDF-6	Upper double flange wheel 16", 6 spoke
S11	Ratchet trigger, SS	16005	Head, aluminum
S1120EZ	Channel, SS (3334-4003 only) EZ-Flow	16005-1	Ratchet shield on head
S116-22	Saw guide bar, 22" SS	16006	Head door, aluminum, use A16006
S119A	Saw guide, SS	16015-10	Floating adjustable motor base plate, 1 phase
S130	Saw cleaner bracket, SS, rear	16015-11	Floating adjustable motor base plate, 3 phase
S155-11	Meat carriage stop thumb screw, SS	16015-12	Motor base plate, special Norway
S155EZ-3	Hex standoff - EZ Flow carriage	16015-2	Motor base plate stud nut
S16005C	Head, SS	16015-3	Motor base plate wing nut
S16006	Head door, SS	16015-4	Motor base plate lock washer
S16007	Channel bracket SS	16112	Head door latch
S16015-1	Motor base plate adjusting stud, SS	16133	Fastener knob, 4 point
S16120	Channel, SS	16154-CE	Table extension
S16132	Saw cleaner bracket holder rear	16155	Meat carriage top & angle
S16217L	Left base panel, SS, see page 29	16155EZ	Meat carriage top & angle, EZ flow
S16217LTP	Left tapered base panel, SS, see page 29	16155-13	Carriage stop angle, SS
S16217R-3	Right hinged base door, SS, s/n 35323 and up	16155-2A	Meat carriage guide
S16273	Meat gauge bracket, SS use(AS16273)	16155-2B	Meat carriage guide spacer, 1/64
S16275	Meat gauge plate, SS	16155-2C	Meat carriage guide spacer, 1/32
S16290	Cleaning unit, SS	16159	Meat carriage bearing
S16335X	Upper wheel hinge plate, SS	16163A	Platter hold down clip
S16Z	Lower guide bracket saw cleaner holder, SS	16163B	Platter neck guard, SS
S18155EZ-1	Carriage top w/weld studs (3334-4003 only)	16163B-1	Platter neck guard, SS, England
S189	Ratchet arm stud, SS	16197	Tension spring gauge

PART NUMBERS AND DESCRIPTIONS (CONT.)

Item No.	Description	Item No.	Description
16200	Carriage stop movable	264-1S	Hand wheel shim
16212	Platter latch	264G	Hand wheel groove pin
16220-1	Carriage stop fixed	267	Meat gauge release cotter pin
16226A-9	Switch button speed nut	271AL	Meat gauge worm gear
16232	Scrap bucket	272-7-1	Knob, 3-point, ⁵ / ₁₆ -18
16239-18	Base interlock plate, SS	272-8	Cap nut, ⁵ / ₁₆ -18, SS
16251AL	Upper V-belt pulley 11.4 x 1, aluminum	272-9	Hex bolt, ⁵ / ₁₆ -18 x 2, SS
16251-11X78AL	Upper V-belt pulley 11.4 x ⁷ / ₈ , aluminum	272-13	Hex bolt, ⁵ / ₁₆ -18 x 1 ¹ / ₄
16251-90X78AL	Upper V-belt pulley 9 x ⁷ / ₈ , aluminum	272-14	Castle nut, ⁵ / ₁₆ -18, SS
16278	Meat gauge arm	277	Lower shaft key
16296-2	Switch bracket, SS	280	Motor shaft key
16301-B	Model & S/N plate	300	Lower shaft woodruff key
16302HT	Saw blade, hard tooth, 124"	310	Waved washer
16303	Lower shaft nut	311	Rubber bumper, fixed stop
16313-100	Owner/operator manual	311-1	Rubber bumper, movable stop
16360	Lower bearing housing	324	Motor shim, ¹ / ₁₆ "
16361	Lower shaft	324A	Motor shim, ¹ / ₈ "
16501	Rubber motor mount, 1 PH	360A1	Angled grease fitting
16502	Motor mount washer, 1 PH	360B-1	Set screw, ¹ / ₂ -13
16508	Motor mount star washer, 1PH	362	Lower bearing housing adjusting cap
16517	Inner race spacer	374	Shell Cassida grease EPS-2
16543	Lower shaft for removable wheel	375	Drive screw, nameplate
16547	Lower bearing housing	376	Drive screw, #10 x ¹ / ₂
16560	Lower removable wheel, 16"	4-30AL	Motor pulley, single-V, 5 x ³ / ₄ bore
16700	Parts repair kit	4-35AL	Motor pulley, single-V, 5 x ⁷ / ₈ bore
17211-22	Finger lift shim .022	4-45AL	Motor pulley, single-V, 6 x ³ / ₄ bore
17211-35	Finger lift shim .035	4-49AL	Motor pulley, single-V, 6 x ⁷ / ₈ bore
175-1-S	Thumb guard nut, SS	415D	Stationary bar, use S415DK
175-2-S	Thumb guard screw, ¹ / ₄ -20 x ¹ / ₂	513	Upper wheel hub cap gasket
175S	Thumb guard, nylon	530	Retaining ring
177	Nylon filler in stationary bar	601	Upper guide bracket
179	Wheel cleaner	602B	Upper blade back up guide
18120EZ-B3	Guide bar, EZ flow, T-shaped	602BFSC	Upper blade back up guide, narrow
230DL	Upper shaft seal, double lip	605	Lower blade back up guide
231DL	Lower shaft seal, double lip	653PC-E	Warning label, English
234	Grease fitting, upper wheel	653PC-F	Warning label, French
237	Upper shaft castellated lock nut	653PC-SP	Warning label, Spanish
238	Upper shaft castellated lock nut washer	6808-G	Toggle switch, 1 phase
247	Upper shaft	71-1	Upper wheel hinge bracket, SS
248	Upper wheel hub cap	708	Danger Exposed Blade decal
256P	Safety pusher plate	710	Decal "Blade Tension"
260	Aluminum slide gib	7810-G	Toggle switch, 3 phase

COMPLETE ASSEMBLIES FOR MODEL 3334

Item No.	Description	Item No.	Description
AS1120EZ	Channel assembly (3334-4003) EZ Flow	A16155	Meat carriage assembly
AS116-22-COS	Saw guide bar assembly, 22", special	A16155EZ	Meat carriage assembly, EZ-flow
AS116-22	Saw guide bar assembly, 22", Al head	A16163-1	Stationary platter assembly
AS116-22SS	Saw guide bar assembly, 22", SS head	A16163-E	Stationary platter assembly, England
AS130	Steel cleaner assembly, SS	A16196	Tension spring assembly
AS16Z	Guide bracket saw cleaner assembly	A16200	Carriage stop assembly, movable
AS16005	Head & door assembly, SS	A16220-1	Carriage stop assembly, fixed
AS16006	Head door assembly, SS	A16278	Meat gauge plate assembly, less release
AS16120	Channel assembly, 37.5"	A16360	Lower bearing housing assembly, w/o wheel
AS16120EZ	Channel assembly, 37.5"- EZ Flow	A16361	Lower shaft bearing assembly
AS16132	Steel cleaner assembly, rear, SS	A16547	Lower bearing housing assembly, w/o wheel
AS16217R	Hinged base door - old style	A175S	Thumb guard assembly
AS16217R-3	Hinged base door - new style	A181155EZ	Meat carriage assembly(3334-4003) EZ-flow
AS16273	Meat gauge bracket assembly	A19-1	Ratchet assembly
AS16273-S275	Meat gauge assembly	A211-AL	Finger lift assembly, removable, Al head
AS16275	Meat gauge plate assembly	A211-COS	Finger lift assembly, removable, special
AS16290	Cleaning unit stamping assembly	A211-SS	Finger lift assembly, removable, SS head
AS16335X	Upper hinge plate assembly, SS	A227	Upper bearing cup/cone assembly
AS249R	Base door lock assembly, right, SS	A247	Upper shaft and bearing assembly
AS415D	Stationary bar assembly, SS	A247-1	Upper shaft and bearing assembly less spacer
A16003U-6	Upper wheel assembly w/o hinge plate	A260	Aluminum slide gib assembly
A16003UDF-6	Upper wheel assembly, double flange, w/o hinge plate	A262	Meat gauge release assembly
A16003U335-6	Upper wheel assembly w/ hinge plate	A295	Wheel cleaner assembly
A16003UDF335-6	Upper wheel assembly, double flange with hinge plate	A363	Lower bearing cup/cone assembly
A16005	Head & door assembly, Aluminum	A415D	Stationary bar assembly, use AS415D
A16006	Head door assembly, Aluminum	A602	Saw guide assembly, upper
A16112	Head door latch assembly	A661-1	Saw guard on head door assembly
		A71-1	Upper wheel hinge bracket assembly

MODELS EQUIPPED WITH STAINLESS STEEL FABRICATED HEADS

Stainless steel heads became available (as optional equipment) starting with Ser. #23265. From Ser. #23265 to Ser. #25059 and starting again with Ser. #36272, these stainless steel heads were mated to the base structure in the same fashion as the aluminum head using the Item #260 slide gib. From Ser. # 25060 to Ser. #36251 the machined blocks were eliminated and the slide gibs redesigned to a dovetail configuration to secure the head.

(The Factory Does Not Recommend Field Conversions)

PARTS EXCLUSIVE TO 3334SS WITH OPTIONAL STAINLESS STEEL HEAD STRUCTURE

Item No.	Description	Item No.	Description
S16005	Head, SS, 1st design, Ser. #23265 to Ser. # 25059, replaced by S16005C	S16006	Head door, SS, all SS heads
S16005B	Head, SS, 2nd design, Ser. #25060 to Ser. # 36251, (uses dovetail slide gibs) replaced by S16005C and 2 ea. #260	16260ZA	Slide gib, dovetail type, Ser. #25060 to Ser. # 36251, no longer available
S16005C	Head, SS, current design, Ser. #36272 to present, (uses #260 slide gibs)	16662	Saw guard on saw guide bar, SS all SS heads

**WEARABLE SAW PARTS THAT WILL FIT
BIRO MODELS 3334 & 3334-4003**



*Item No. S119A
LOWER SAW GUIDE



Item No. S130
SAW CLEANER BRACKET

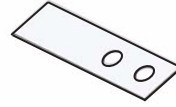

*Item No. 131
STEEL BLADE CLEANER



*Item No. S265
MEAT GAUGE SPRING

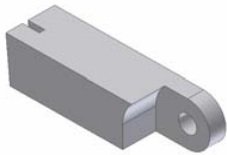

*Item No. 177
NYLON FILLER

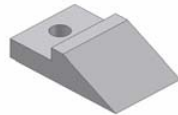

*Item No. 179
WHEEL CLEANER



*Item No. S229
WHEEL CLEANER
ARM SPRING



*Item No. S244
WHEEL CLEANER ARM STUD



*Item No. S268
FILLER & GUIDE STUD



Item No. S295
WHEEL CLEANER ARM

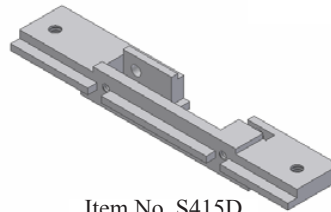

Item No. S415D
STAINLESS STATIONARY BAR
OPTIONAL

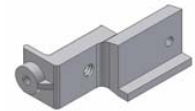

Item No. 601
UPPER SAW GUIDE BRACKET



*Item No. 602B
UPPER SAW GUIDE
W/ BEVELED CARBIDE

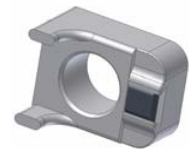

*Item No. 605
LOWER BLADE BACKUP
W/ CARBIDE
(before S/N 48681)



NOT TO SCALE



*Item No. S608
LOWER BLADE BACKUP
W/ CARBIDE
(after S/N 48682)

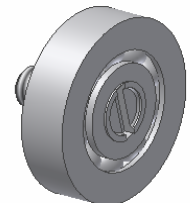

Item No. 16159
CARRIAGE BEARING

USE PARTS REPAIR KIT PART NO. 16700

***Included in parts repair kit.**

WARNING LABEL LOCATIONS ON MACHINE

WARNING



DO NOT Use Unless Trained and Authorized By Supervisor And Over 18 Years Old.
 READ Operation Manual Thoroughly Before Operating.
 ALWAYS Keep Hands Clear of Saw Blade and other Moving Parts. Turn Off Saw when Finished Cutting.
 ALWAYS Keep Blade Guard Adjusted to 1/2" Above the Product being Cut.
 ALWAYS Use End Cut Pusher Plate When Cutting Smaller Piece of Product.
 DO NOT Use Saw if it is Altered, Damaged, Improperly Maintained, or If Warnings Are Illegible or Missing.
 ALWAYS Disconnect and Unplug from Main Power Source and Perform LOCKOUT/TAGOUT Before Cleaning or Servicing.
 Failure to comply with warning could result in serious bodily injury.

#653PC-E



ATTACH ON HEAD STRUCTURE BELOW
MODEL/SERIAL NUMBER TAG

Item No. 653PC-E



ATTACH TO CHANNEL BRACKET NEXT
TO SWITCH BUTTONS



MUCHO CUIDADO



NO Opere Esta Sierra Sin Haber Sido Entrenado Para Ello Ni Tampoco Sin Autorizacion de un Supervisor. Uno Tiene que Haber Cumplido 18 Años Para Operarla. LEA Cuidadosamente el Manual de Operacion Antes de Usar Este Equipo.
 SIEMPRE Guarde las Manos a Salvo de la Hoja de Serrar y de Otras Partes Moviles. Cierre el Interruptor Despues de Terminar de Cortar.
 SIEMPRE Tenga Ajustado el Guardasierra Para que Quede a 1/2" Por Encima del Producto que se Corta.
 SIEMPRE Haga Uso de la Placa de Empuje Para Cortes de Extremos al Cortar Trocitos Pequeños.
 NO Utilice la Sierra si se Halla Alterada, Danada o si No ha Sido Debidamente Mantenida o si la Advertencia es Ilegible o si Falta Esta.
 SIEMPRE Desconecte el Equipo Decenchufandolo de la Fuente de Fuerza. Dejelo Bajo Llave o con Etiqueta que Prohiba su Uso Antes de Limpiarlo o Hacer Trabajos de Mantenimiento.

#653PC-SP

Item No. 653PC-SP

WARNING LABEL LOCATIONS ON MACHINE

ALWAYS LOWER GUARD TO HEIGHT OF PRODUCT



DANGER EXPOSED BLADE



ITEM NO. 708 "DANGER EXPOSED BLADE" DECAL

ATTACHED TO SAW GUARD ON SAW GUIDE BAR

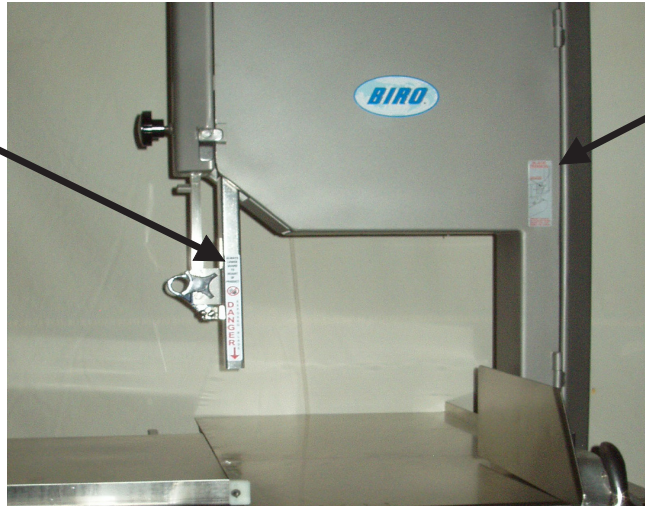

ITEM NO. 710 "BLADE TENSION" DECAL

ATTACHED TO HEAD DOOR AS SHOWN

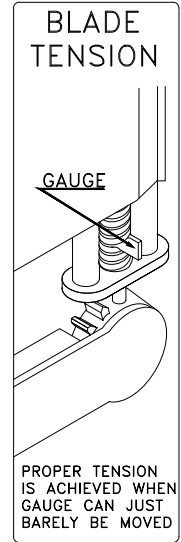

ATTACH TO HINGED RIGHT BASE DOOR

CAUTION

** This saw has been equipped with a "REMOVABLE" lower wheel **

ATTENTION: ELECTRICIAN/SERVICE TECHNICIAN
** READ FIRST BEFORE STARTING POWER CUTTER **

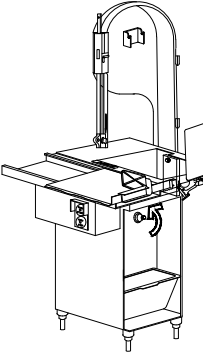

IMPORTANT

This saw has been electrically tested at the factory, but electrical phasing for proper rotation may not match your electrical supply.

WITH LOWER SAW WHEEL REMOVED, check rotation of shaft. Rotation must be counterclockwise when facing shaft. Failure to confirm correct rotation could result in the wheel dislodging.

ITEM NO. 16716 "CAUTION" LABEL USE ON MACHINES WITH REMOVABLE LOWER WHEEL



OPERATOR'S SIGNATURE PAGE

WARNING
READ AND UNDERSTAND THIS ENTIRE
MANUAL BEFORE SIGNING BELOW

MY SIGNATURE ATTESTS THAT I HAVE COMPLETELY READ AND UNDERSTAND THIS MANUAL. I REALIZE THAT THIS MACHINE, IF OPERATED CARELESSLY, CAN CAUSE SERIOUS INJURY TO MYSELF AND OTHERS.

NAME (PRINT)	SIGNATURE	SUPERVISOR'S INITIALS	DATE

LIMITED WARRANTY:

WARRANTY: The BIRO Manufacturing Company warrants that Model 3334 Power Saw will be free from defects in material and workmanship under normal use and with recommended service. BIRO will replace defective parts, which are covered by this limited warranty, provided that the defective parts are authorized for return, shipping charges prepaid, to a designated factory for inspection and/or testing.

DURATION OF WARRANTY: The warranty period for all parts covered by this limited warranty is one (1) year from date of Inspection/Demonstration advised on the returned Warranty Registration Card, or eighteen (18) months from original factory ship date, whichever occurs first, except as noted.

PARTS NOT COVERED BY WARRANTY: The following are **not** covered by this limited warranty: wearable parts on the cleaning system such as wheel cleaners (Item No. 179), saw blade cleaners (Item No. 131) blade backup guides (Item No's. 602B, 605 and S119A), and the nylon filler (Item No. 177). This limited warranty does not apply to machines sold as used, rebuilt, modified, or altered from the original construction in which the machine was shipped from the factory. (WATER CONTAMINATED ELECTRICAL SYSTEMS ARE NOT COVERED UNDER THIS LIMITED WARRANTY.) BIRO is not responsible for electrical connection of equipment, adjustments to switch controls or any other electrical requirements, which must be performed only by a certified electrician. BIRO is not responsible for service charges or labor required to replace any part covered by this limited warranty or for any damages resulting from misuse, abuse, lack of proper or recommended service.

EXCLUSION OF WARRANTIES AND LIMITATION OF REMEDIES: BIRO gives no warranties other than those expressly stated in this limited warranty. THE IMPLIED WARRANTY OF MERCHANTABILITY, THE IMPLIED WARRANTY OF FITNESS FOR PROCESSING FOOD PRODUCTS, AND ALL OTHER IMPLIED WARRANTIES ARE SPECIFICALLY EXCLUDED. BIRO IS NOT LIABLE FOR CONSEQUENTIAL OR INCIDENTAL DAMAGES, EXPENSES, OR LOSSES. THE REMEDIES PROVIDED IN THIS BIRO LIMITED WARRANTY ARE PURCHASER'S SOLE AND EXCLUSIVE REMEDIES AGAINST BIRO.

REGISTRATION CARDS: You must sign, date and complete the warranty registration card supplied with each machine. The warranty card must be returned to The BIRO Manufacturing Company for proper registration. If no warranty card is returned to BIRO, the warranty period will begin from the date the machine was originally shipped from the factory.

HOW TO GET SERVICE:

1. Contact the agency from whom you purchased the machine; or
2. Consult the yellow pages of the phone directory for the nearest authorized dealer; or
3. Contact Biro Manufacturing Company for the nearest authorized service entity in your area.

BIRO MANUFACTURING COMPANY

1114 West Main Street
Marblehead, OH 43440
Ph. 419-798-4451
Fax 419-798-9106
Service@birosaw.com
www.birosaw.com

ITEM NO.: 16313-100

PTCT: MD 3334-100-5-18-40 B