

Model RL Ring Lifter Model FP1000 Feed Screw Puller

PROVISUR®
TECHNOLOGIES

AM2C® Beehive® Cashin® Formax® TST® Weiler®
©2011 Provisur® Technologies

One Person Time Saver

Model FP1000
Feed Screw Puller

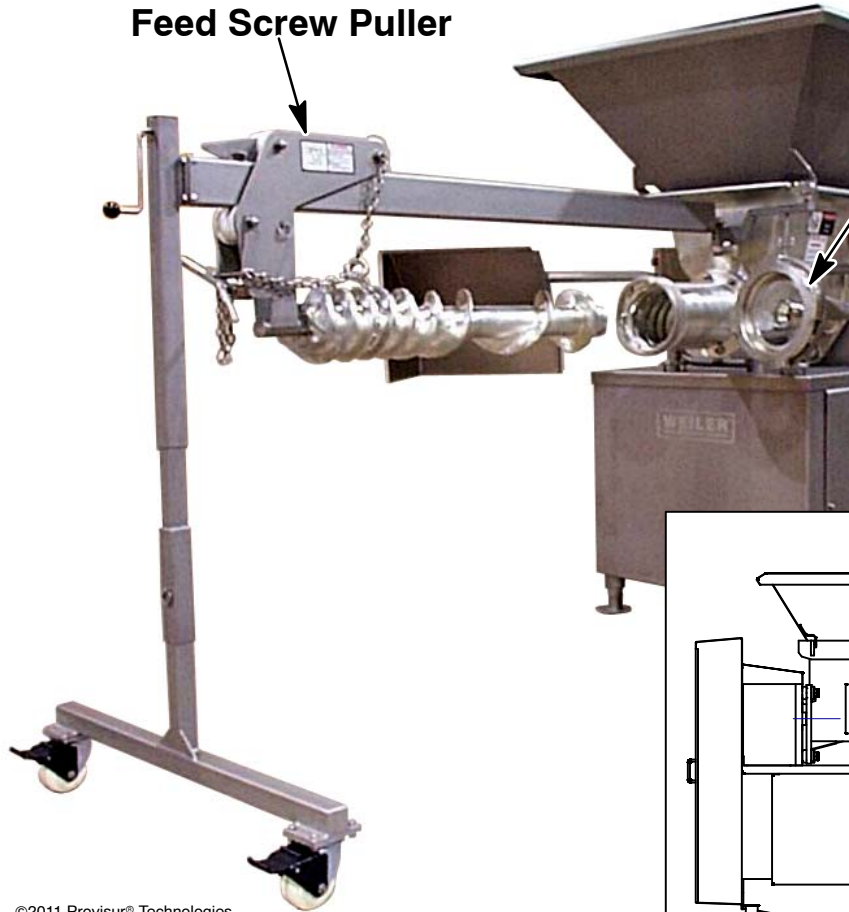

©2011 Provisur® Technologies

Model RL Ring Lifter

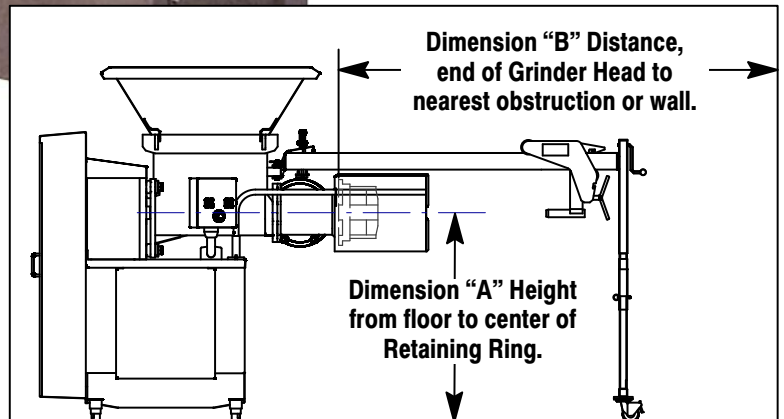
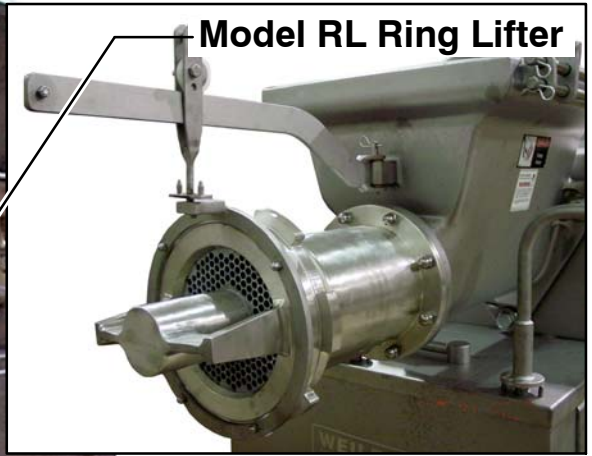

Standard RL Ring Lifter Advantages:

1. Available for all Weiler® 8-5/8", 11", 16" Grinders, AG's & MG's.
2. Allows easy removal of grinder ring without risk of dropping.
3. Saves wear and tear on grinder head and ring.
4. Easier to engage threads.

Standard FP1000 Advantages:

1. Available for all floor mounted Weiler® 8-5/8", 11", 16" Grinders, AG's & MG's.
2. Eliminates damage to feed screw and head upon removal and installation of the feed screw.
3. Easy to install, adjust and use.
4. Please furnish discharge height ("A") of your grinder(s) and space between end of grinder head and nearest obstruction ("B").



1116 East Main Street • Whitewater, Wisconsin 53190-2103, USA
262-473-5254 • 800-558-9507 • Fax 262-473-5867

Grinder Model Number	Grinder Serial Number	DIMENSIONS	
		"A"	"B"

* For additional information and firm prices, please contact Provisur® Technologies.



11814 Election Road • Suite 140 • Draper, UT 84020 USA
Tel: 801-561-4211 • Fax: 801-562-5857