

Automatic traysealers

Food



MULTIVAC is a major manufacturer of automatic traysealers. Each machine is individually designed to each customer's specific requirements in terms of tray and product infeed, discharge of packs, marking and quality inspection. It dovetails seamlessly into your new or existing production environment, either as a stand-alone machine or as part of a fully automated packaging line. Reliability, durability and a comprehensive service make MULTIVAC a resilient link in your production line.

Improved packaging with MULTIVAC traysealers





Simple operation and production data acquisition

MULTIVAC benefits

- MULTIVAC Hygiene Design™
- High production output and pack quality
- Individually tailored solutions
- Maximum output with the minimum footprint
- Energy efficiency
- Pioneering ergonomics and user-friendliness
- Long service life
- Comprehensive range of solutions for infeed and removal of trays
- Customized solutions for tray loading
- Complete supply for packaging lines

Energy-efficient servo lifting unit

Easily removable conveyors for convenient cleaning

Recipe for a successful tray pack

MULTIVAC began building the first traysealers for food packaging in the 1980s. Today, traysealers have much more capacity, compared to what was possible then. They are particularly easy to clean with a hygienic stainless steel design and can be quickly converted to different tray shapes and sizes.

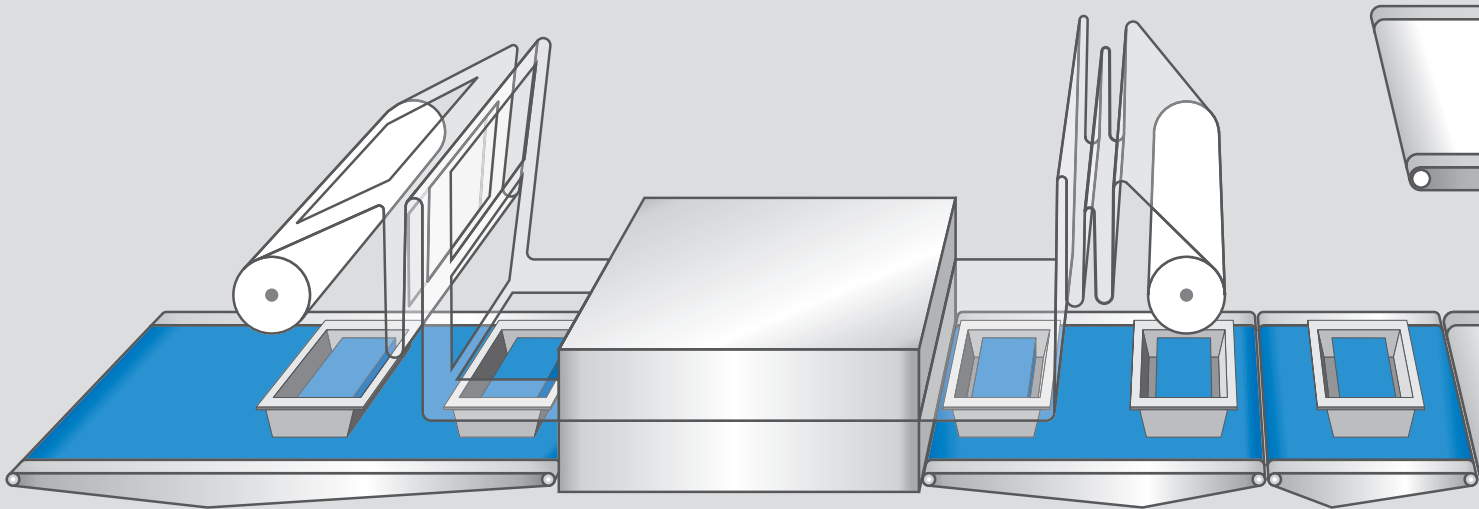

① **Trays**

Pre-made trays are used for packaging. The tray denesting can be manual or automated.

② **Loading**

The filling of the trays is performed manually or automatically in the loading area.

③ **Sealing**

In addition to the simple sealing of a tray, MULTIVAC provides atmosphere exchange or a vacuum process for manufacturing skin packaging for the production of MAP packaging.

The upper web is applied to the filled trays in the sealing die. The upper web and tray are sealed with a seal seam, and then the upper web is cut.

④ **Tray discharge**

Conveyors, belts or roller conveyors transport the tray out of the machine. The product can be further processed either manually after being removed from the machine or automatically in case of downstream line integration-capable machines.

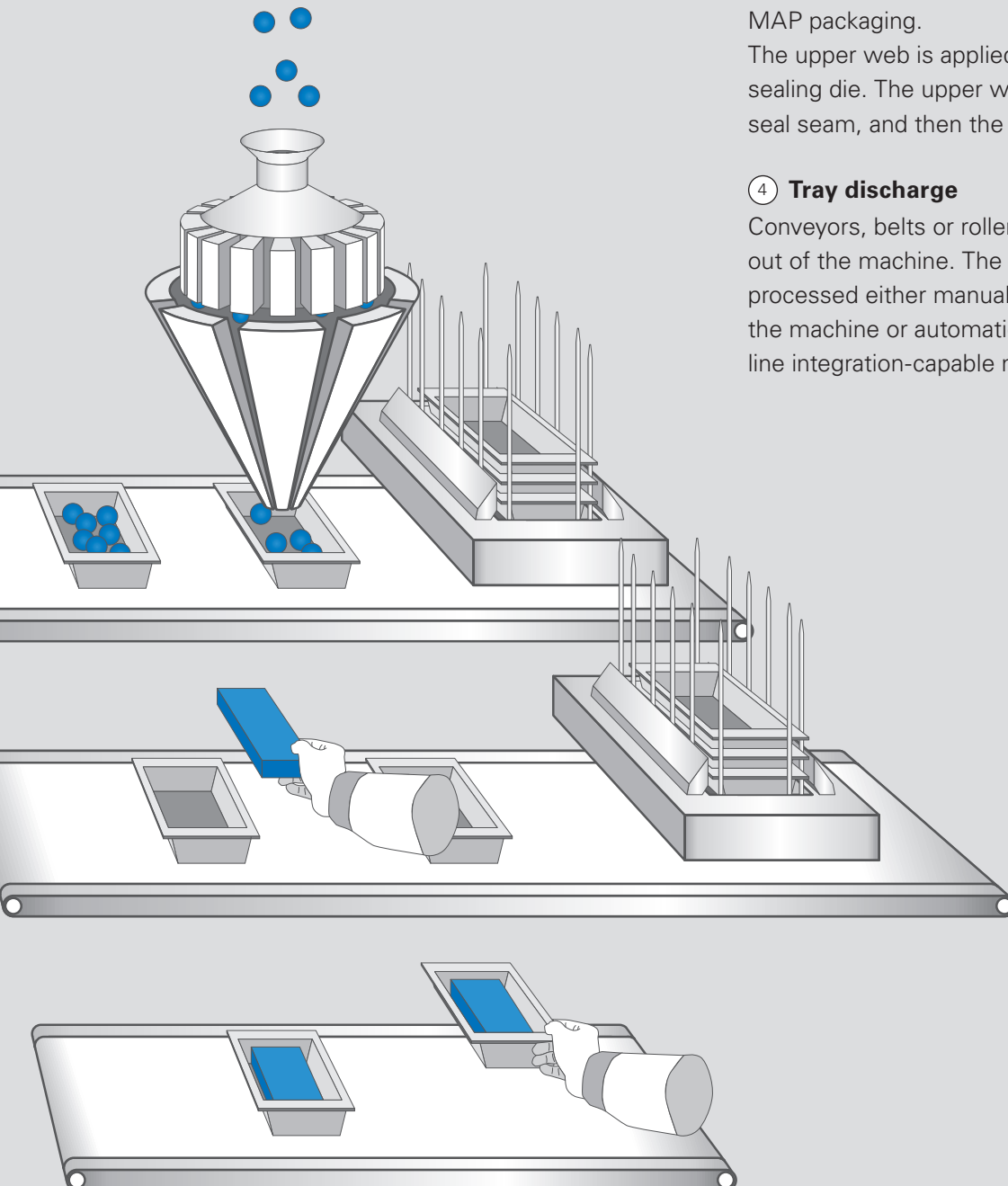

Machine classes

What are your requirements of a traysealer? Special tray shapes? High level of versatility? Automatic tray infeed? A small footprint? MULTIVAC offers a uniquely wide range of machines to meet your requirements.



	T 300	T 600	T 700
	Tray packaging in the smallest space	Smallest traysealer which can be integrated in lines	Highest output in the smallest space
Batch size	Small batches, fast product change	Small to medium batches, fast product change	Large batches. fast product change
Output (cycles/min)	★ ★ ★ ★ ★	★ ★ ★ ★ ★	★ ★ ★ ★ ★
Equipment options	★ ★ ★ ★ ★	★ ★ ★ ★ ★	★ ★ ★ ★ ★
Die size	★ ★ ★ ★ ★	★ ★ ★ ★ ★	★ ★ ★ ★ ★
Max. pack tracks	3	1	2
Forms of packaging			
Tray material	Rigid film, aluminium, carton, foam	Rigid film, aluminium, carton, foam	Rigid film, aluminium, carton, foam



T 800

Highest cycle output
in fully automated
packaging lines

T 850

Highest cycle output
in fully automated
packaging lines

Customised machines

Traysealers for special
applications

Very large batches,
fast product change

Very large batches,
fast product change

Very large batches

★★★★★

★★★★★

★★★★★

★★★★★

★★★★★

★★★★★

★★★★★

★★★★★

★★★★★

2

2

multiple-track



Rigid film, aluminium,
carton, foam

Rigid film, aluminium,
carton, foam

Rigid film, aluminium,
carton, foam



Deutsches Lachsfilet



Energiewert
1216 kJ
292 kcal
15 %

300g e

Je 100 g: 811 kJ / 195 kcal

Ungeöffnet bei unter +7 °C zu verbrauchen bis:



BBQ
AUCH IDEAL ZUM GRILLEN



Large range of packs

The diversity of food and its forms of presentation are continually increasing on supermarket shelves. At the same time, the demands for the trays in terms of tray shape and material are also increasing. This wide range of packs can be produced reliably and efficiently on MULTIVAC traysealers. We design each machine individually to fit specific customer requirements.



Trays and film

On MULTIVAC traysealers, all standard trays can be sealed in plastic or other materials in a variety of forms. The upper web is optimally utilized so that only minimal film trim lattice is created.

Tray materials

- Mono and composite plastic
- Box
- Foam
- Aluminium
- Renewable resources (such as based on cellulose)

Tray shape

- Rectangular
- Multi-sided
- Round
- Oval
- Several cavities
- Slice pack

Film

- Unprinted film
- Printed film
- Lid film
- Fish film
- Temperature-resistant film
- Mirabella
- Film from renewable resources (such as based on cellulose)



Cutting systems

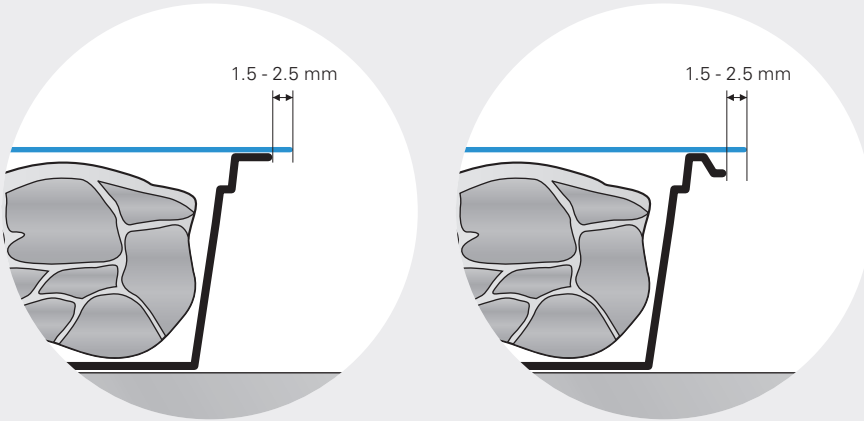

Outside cut

With the outside cut, the upper web protrudes 1.5 to 2.5 mm beyond the edge of the tray ("cutting protrusion"). This type of cut is technically much easier than inside cut, and it functions with a wide range of upper webs.

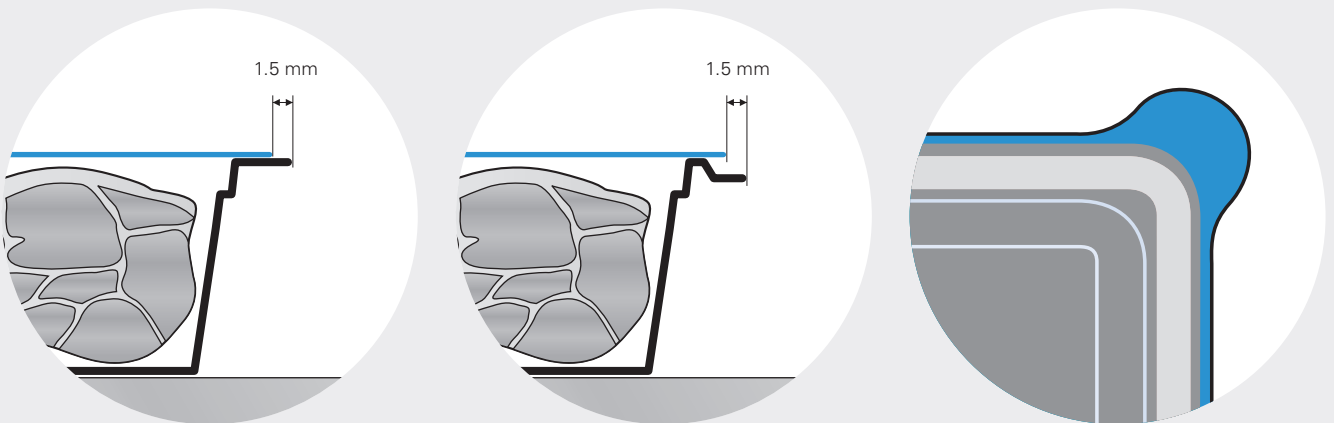

Inside cut

With the inside cut, the cutting line on the upper web runs inside the outer contour of the tray. This enables an elegant visual appearance to be achieved. The technical effort of this cutting system is greater than with outside cut.

Peel corner

Peel corners can be used as an opening aid with both the inside cut and the outside cut. The unsealed tab can be placed inside the tray contour, or it can protrude beyond the tray contour to provide a better grip.

Modified atmosphere packaging

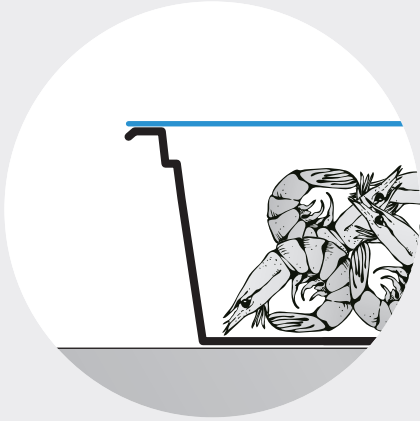

Natural atmosphere

The simplest technical solution is sealing of the trays without modified atmosphere. These packs protect the product from contact and mechanical influences, but do not have any properties which extend shelf life.

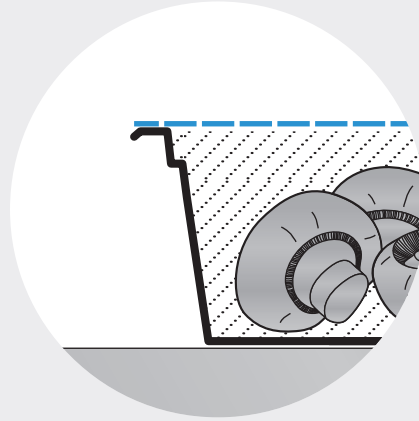

Equilibrium atmosphere (EMAP)

The permeability of the upper web is matched to the respiration rate of the product by means of microperforation. This enables an equilibrium atmosphere to be established, which extends the shelf life of sensitive, respiring products such as fruit, vegetables, salads and herbs.



Modified atmosphere (MAP)

In case of packs with modified atmosphere, the atmosphere in the pack is replaced with a gas mixture matched to the product in order to maintain the form, colour and freshness of the product. This modified atmosphere packaging usually consists of carbon dioxide, nitrogen and oxygen.

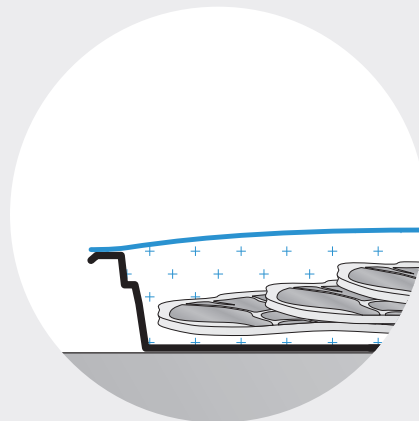

Lid pack

Lid pack is a MAP pack for flat products. As the upper web, a special lid film is used which shrinks slightly after sealing and therefore bulges over the tray. The small head space of the pack makes for reduced consumption of protective gas.

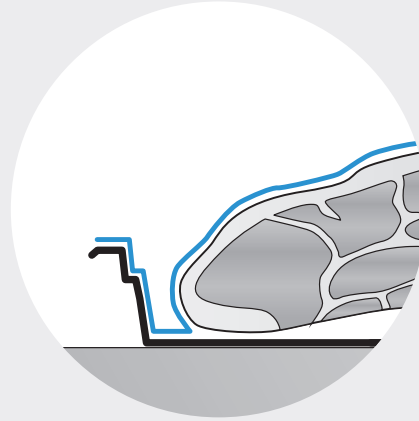
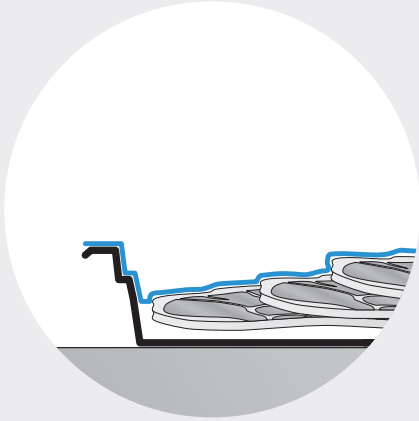

MultiFresh™ vacuum skin packs

Packaging under vacuum extends the shelf life of products, since the biochemical degradation of the product is slowed down by the removal of the atmosphere. In the production of MultiFresh™ skin packs, trays and MultiFresh™ skin films are used that enclose the product tightly and seal the entire surface with the tray.

As flat products may be slightly compressed in the process, vacuum skin packs without product protrusion are particularly suitable for pressure-insensitive foods. For pressure-sensitive products as well as packs with product protrusion, we offer an attractive solution with MultiFresh™ Pro. In which, the upper web encloses the product tightly and free of tension without affecting the shape of the product and without altering its decorations.

Atmosphere exchange technology	Description	Application
Evacuation and gas flushing	The air is evacuated from the pack, and the desired gas mixture is supplied. Then the pack is sealed.	Standard application
Gas purging	The modified atmosphere is injected into the pack, and the air is displaced. Then the pack is sealed.	All products that do not allow evacuation due to air inclusions – due to the risk of bursting or overfoaming, for example.



MULTIVAC T 850



Flexibility

MULTIVAC traysealers are designed for a safe and reliable packaging process. Faster and easier die and film change allows for maximum flexibility.

Tray transport	18
----------------	----

Format change	20
---------------	----

Film handling	22
---------------	----

Register mark control	23
-----------------------	----

Tray transport systems

The MULTIVAC portfolio includes traysealers which are equipped with different tray transport systems. In this way, any trays with unusual shapes and properties can be safely processed in all areas. This includes single-track and multi-track systems. MULTIVAC transport conveyors can be designed for both one- and two-track systems.

Traysealers	Rods	Grippers	MULTIVAC Tray Carrier™ System
T 300	•		
T 300 H	•		•
T 600		•	
T 700 XS		•	•
T 700 XS, 2-track with integrated line converger		•	•
T 700 S		•	•
T 700 S, 2-track with integrated line converger		•	
T 700		•	•
T 700, 2-track with integrated line converger		•	
T 800 S		•	
T 800 S, 2-track with integrated line converger		•	
T 800		•	
T 800, 2-track with integrated line converger		•	
T 850		•	
T 850, 2-track with integrated line converger		•	

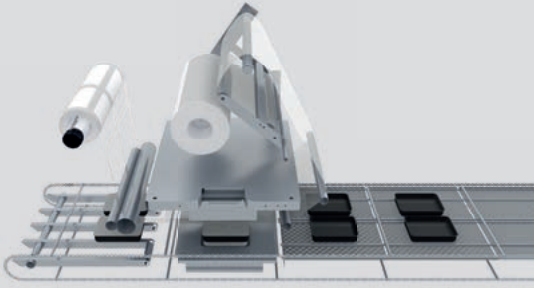

Principle of the rods

The trays are pushed through the traysealer by means of rods, which are guided on both sides by chains. This ensures secure tray transport, since the position of the trays in relation to the die is precisely defined.

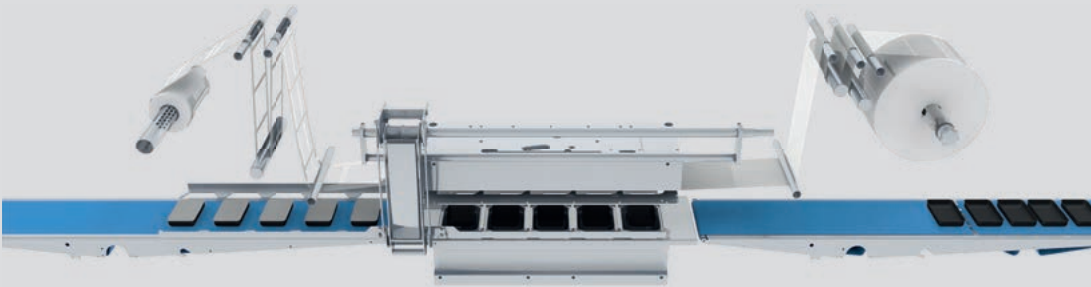

Principle of the gripper system

The die is loaded and unloaded with trays by means of a gripper. Due to the servo motor drive of the gripper, all gripper movements are precisely defined in the HMI. This ensures secure transport of the filled trays.

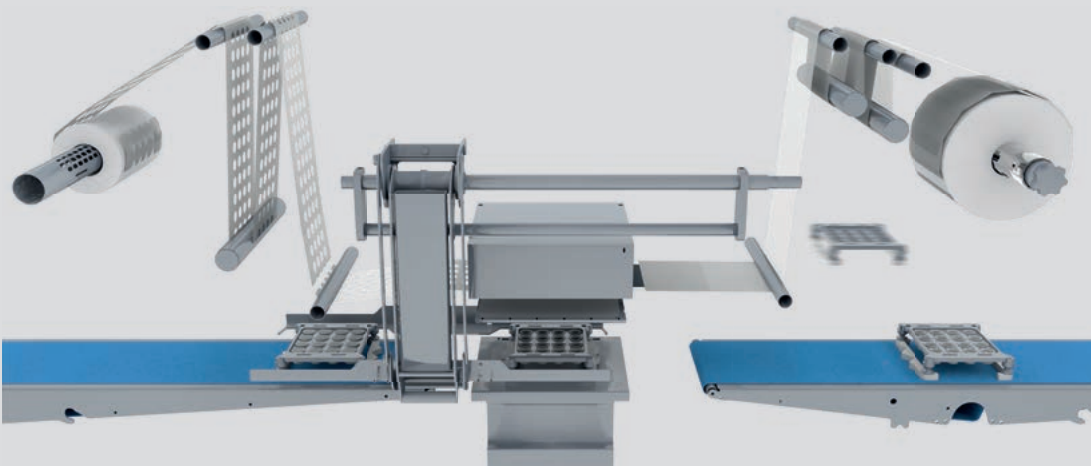

MULTIVAC Tray Carrier™ System MTD

The Tray Carriers are used as the transport system for those trays, which cannot be transported with standard systems due to their shape. The Tray Carriers can be designed as multi-track and multi-row, and they can be loaded and unloaded by means of a gripper system. The use of the MULTIVAC Tray Carrier™ System increases flexibility and output of the traysealer with regard to processing different tray geometries.

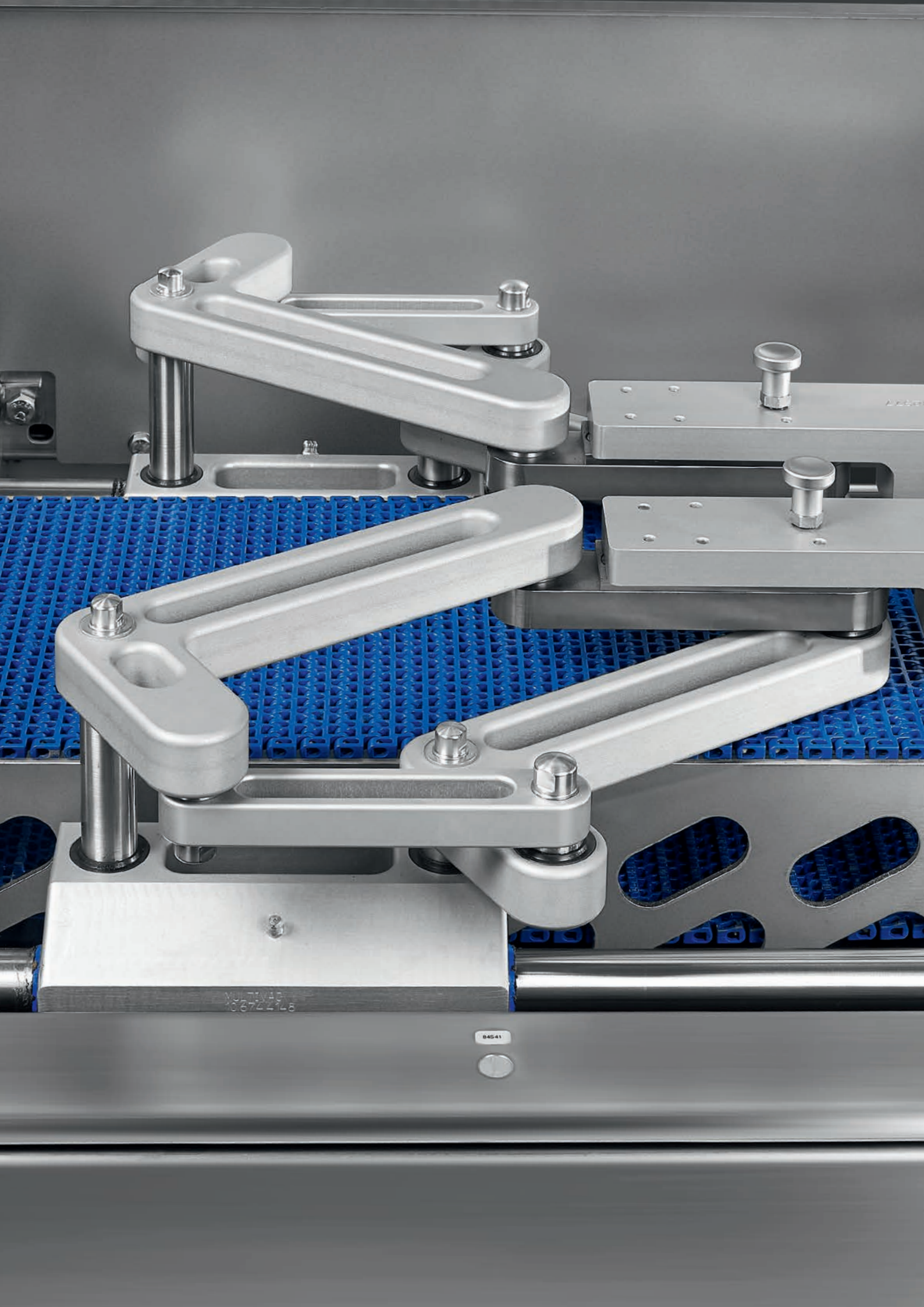

MULTIWAY
10372-118

84541

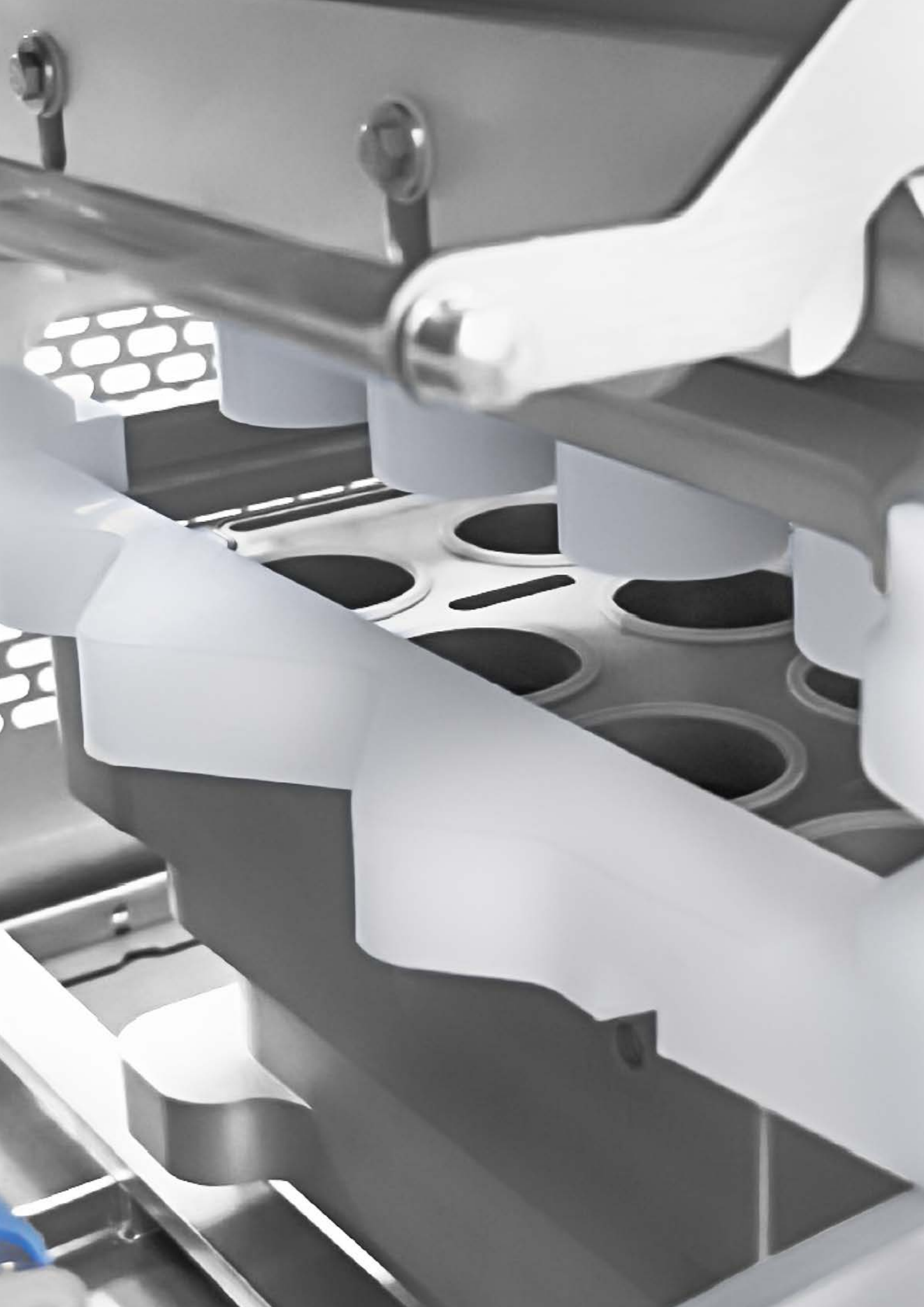

Format changing systems

The greater the number of different pack formats produced on one machine, the more critical quick format changes become. For this purpose, MULTIVAC traysealers are equipped with format change systems that are designed to ensure easy and safe conversion of the machine. We would be very pleased to give you expert advice so that you can find the ideal solution.

Traysealers	Complete die (with automatic unlock mechanism)	Changeable die top section	Separate bottom section (with automatic unlock mechanism)	Bottom section fixed with changeable tray carriers, tray lifters and filling plates	Storage and transport system for the MULTIVAC Tray Carrier™
T 300		•		•	
T 300 H		•		•	•
T 600		•		•	
T 700 XS	•		•		•
T 700 S	•		•		•
T 700	•		•		•
T 800 S	•		•		
T 800	•		•		
T 850	•		•		

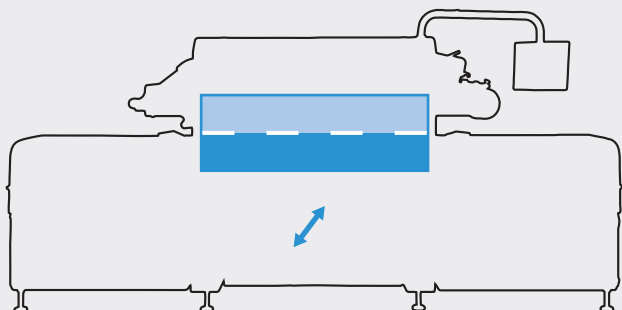

Changing the complete die

The lifting unit moves the die bottom section for the change up until the die is closed. The die top section is automatically unlocked and moves with the die bottom section down into the changing position. The complete die can be pulled onto the die changing trolley. The new die is moved as a complete unit from the die changing trolley into the traysealer.

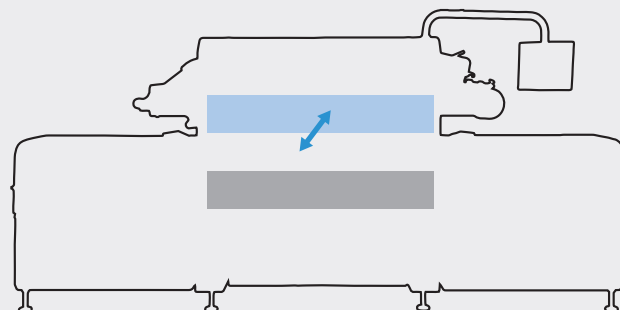

Separate changing of the die top section

The die top section is unlocked manually and moved onto the die changing trolley. In this way, implementation of maintenance and cleaning work can be simplified.

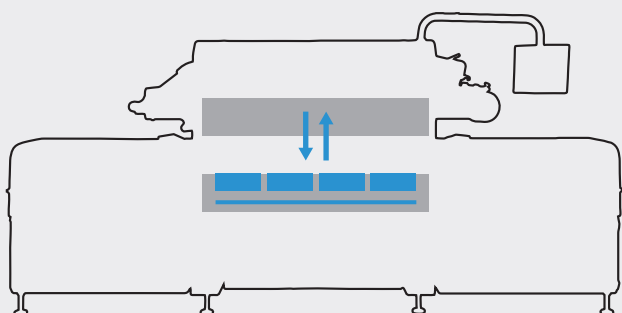

Fixed die bottom section with removable tray carrier

The die bottom section remains in the traysealer for format change. Tray carriers, tray support carriers and filling plates are changed manually.

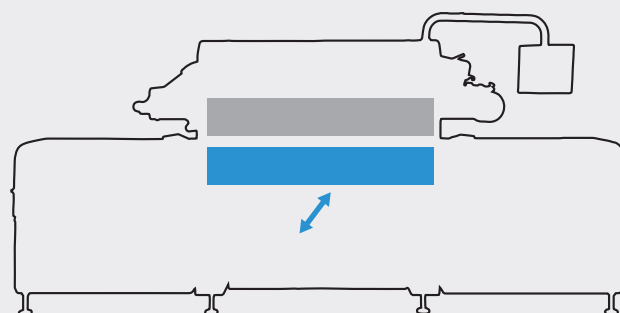

Separate changing of the die bottom section

The die bottom section is unlocked automatically and slid onto the die changing trolley. In this way, implementation of maintenance and cleaning work can be simplified.

Film handling

The film advance system of MULTIVAC traysealers ensures that the upper film is very precisely positioned in the sealing die, which results in the optimal use of the material.

Film unwind

MULTIVAC traysealers are equipped with a 3" standard film unwind mandrel. These can be operated either mechanically or automatically. 6" adapters are available as an option for all traysealers.

Tandem film unwind

The tandem film unwind consists of 2 film unwind mandrels. This enables the traysealer to be loaded with 2 web rolls at the same time, thereby reducing the film changing time.

Film buffer

The film buffer is fed from the web roll and guides the film to the sealing die. In this way, the mechanical stress of the upper web is reduced.

Film trim winder

The film trim winder ensures precise tensioning of the film trim lattice, and it winds this up in a compacted form. This means that it has the same capacity as the web roll and can be emptied when the web roll is changed.

Register mark control

The register mark control is available as an option for all traysealers. It ensures that register marks are detected reliably.



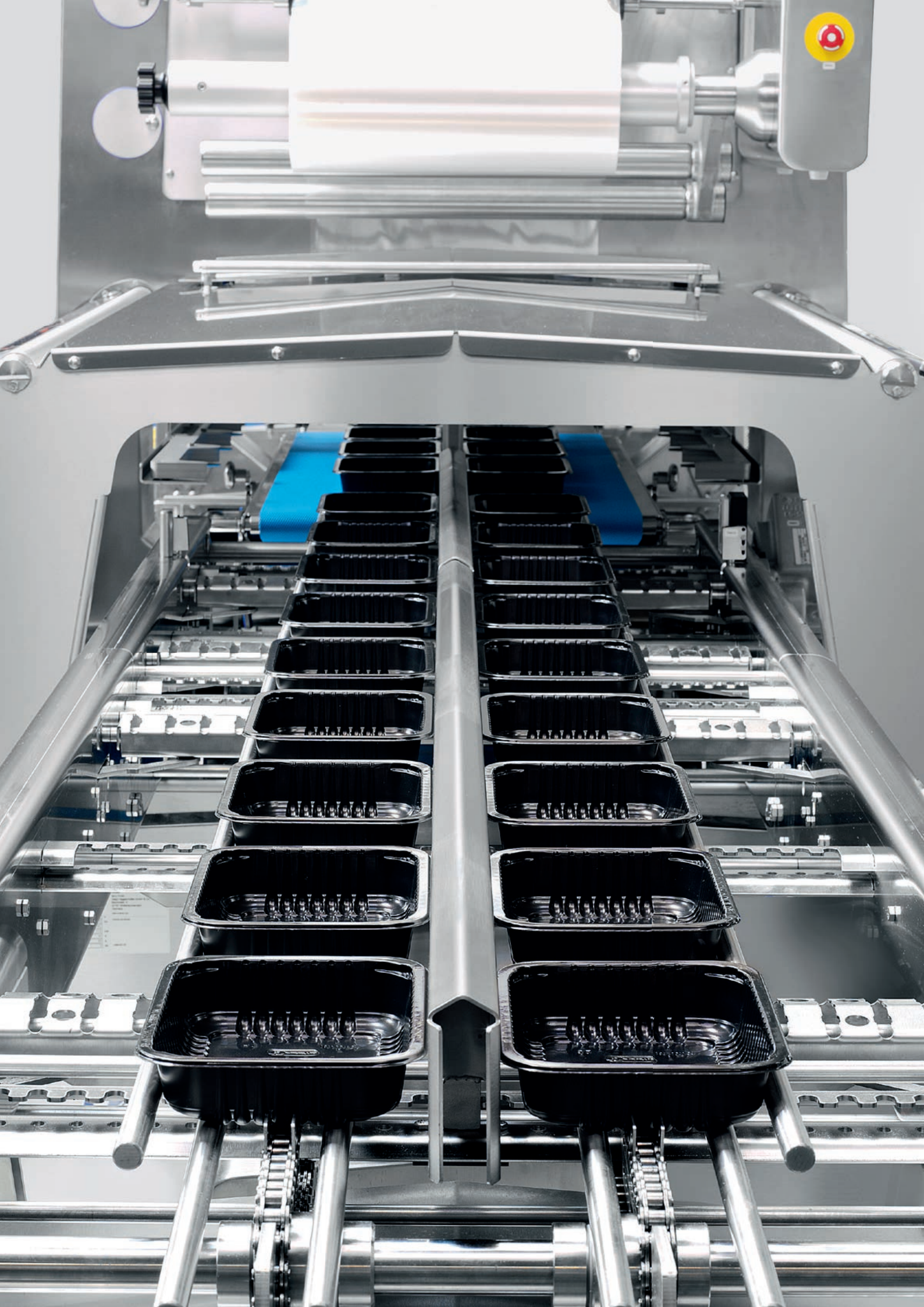

Upstream and downstream processes

MULTIVAC machines are designed for an efficient overall process. That's why we offer a broad range of solutions for upstream and downstream processes. These cover all service areas and various levels of automation. We easily integrate existing infeed and discharge systems into the MULTIVAC packaging solution.

Tray infeed	26
-------------	----

Product infeed	28
----------------	----

Tray discharge	30
----------------	----

Tray infeed

The spectrum of MULTIVAC systems for precise and reliable tray infeed is as diverse as the needs of our customers. The portfolio includes solutions in all areas and levels of automation. We seamlessly integrate existing tray infeeds into the overall concept.

Transfer conveyor

The transfer conveyor is a component of the traysealer. It transports the trays to the gripper.

Transport conveyor

The transport conveyor is integrated in the traysealer. It regulates the flow of trays to the transfer conveyor.

MDC

The drag chain can operate either continuously or cyclically. It feeds the trays to the traysealer. The trays are guided at the sides and at the trailing edge. They have a precisely defined position.



Line diverger

A line diverger is required to diverge a single-track product flow for a two-track traysealer. The infeed to the line diverger can be performed either by an Intralox discharge belt or a drag chain.

Turning station

The turning station can change the alignment of the tray by 90 degrees. It is used if a different tray alignment is required for optimum filling of the tray than for optimal utilization of the die format.

MCS

The MCS transport conveyor always operates continuously. It feeds the trays to the traysealer. A side guide ensures that the trays are guided to the middle and precisely transferred to the traysealer.

Stand-alone MDC

The stand-alone drag chain has the same method of functioning as the integrated chain conveyor. It can only be used in combination with a downstream buffer conveyor or line diverger. As a result, an undefined tray stream can be processed in an automated process.

Denester

The MTD denesters denest the trays and position them precisely on the product infeed conveyor. The manual effort in supplying the trays can be reduced by equipping the denester with a buffer.

Product infeed conveyor

Product infeed conveyors operate either continuously or cyclically. Continuously operating product infeed conveyors are mostly used for manual loading or portion-to-pack solutions. Cyclical infeed is often used in automatic loading of trays by fillers, multihead weighers and robots.

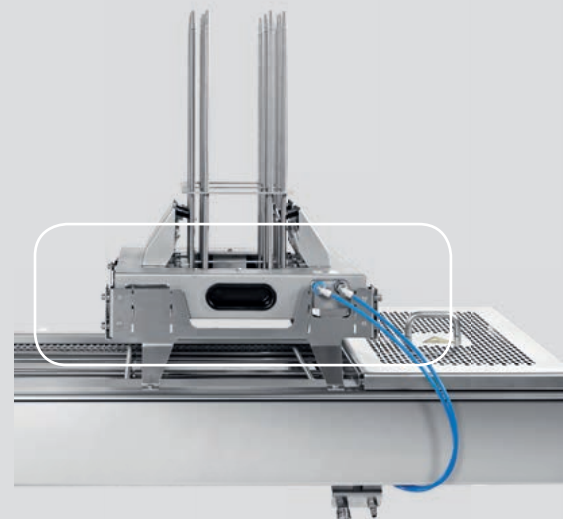
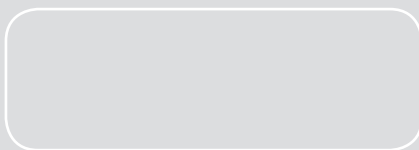
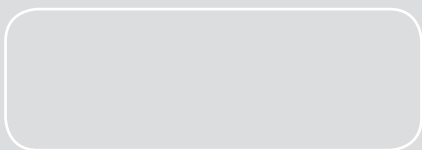

MTD denester

Automatic denesting supports the efficient manual or automatic loading of trays. MULTIVAC denesters of the MTD series reliably denest trays in a wide range of shapes and materials at high output. The trays are placed precisely on MULTIVAC drag-chain infeed systems (MDC) or MULTIVAC conveyor systems (MCS).

MULTIVAC denesters are characterised by their

- Robust and durable stainless steel construction
- MULTIVAC Hygienic Design™ for maximum hygiene and easy cleaning
- Small space requirement thanks to integration in MULTIVAC drag-chain infeed systems (MDC) and MULTIVAC conveyor systems (MCS)
- The denester is controlled at the traysealer's control terminal, and the denester settings are saved in the product recipe
- Reliable and ergonomic operation for short downtime
- The magazine height can be individually tailored to the tray features for easy loading
- Fast format change (denester head, magazine) in less than 60 seconds
- Simple adaptation of the tray drop height
- Energy-efficient servo drive



Product infeed

If you are already using proven systems for filling trays, we ensure easy connection of such systems to the MULTIVAC traysealer.

At the same time, we have a comprehensive range of feeder solutions for products of different consistency and temperature, which we integrate into the tray packaging line on every level of automation:

- Manual loading
- Loading robot
- Filler
- Multihead weigher
- Portioning into pack

Loading system	MCS	MDC				Rods	MTC	Plate chain
		Continuous	Row advance	Partial format advance	Format advance			
Manual	•	•	•	•	•	•	•	
Robot		•	•	•	•	•	•	
Moving filler		•				•		
Static filler			•	•	•	•	•	
Multihead weigher			•	•	•	•	•	
Portion to pack	•							

Tray discharge

For discharge of trays and transfer to follow-up processes, we offer a wide variety of solutions that also include converging multi-track product streams. MULTIVAC traysealers are equipped according to your individual requirements.

Roller conveyor

The trays slide without any sorting into a reject bin or onto a turntable. The roller conveyor is the standard tray discharge of the T 300 and is only available for this model.

Discharge conveyor

We offer different types of discharge conveyors in regards to materials, number of tracks and length. These can be operated in different types of discharge mode.

Two-track discharge conveyor

This Intralox transport conveyor can be used for continuous and cyclical tray discharge. A variety of transport modes can be selected. For single-track processing, the MBS converging system is capable of being integrated downstream from the discharge conveyor.

Two-track discharge conveyor with integrated line converger

The Intralox transport conveyor is used in different discharge modes for single-track processing of trays.



Discharge conveyors for traysealer models

T 300 discharge conveyor with integrated converging

The height-adjustable Intralox conveyor transport allows continuous or cyclical discharge of trays. The converging can be from three pack tracks to one pack track or two pack tracks to one pack track. In a T 300 designed for one pack track, the discharge conveyor can be used with integrated converging for balancing the tray spacing for subsequent processes.

One-track discharge conveyor T 600

With the T 600 traysealer, a continuously operating Intralox transport conveyor is used.

One-track discharge conveyor T 700, T 800

The transport conveyor enables continuous or cyclical tray discharge in different discharge modes.

Compensation conveyor

The compensation conveyor adjusts the spacing between the trays for downstream systems such as checkweighers, metal detectors, etc. It simultaneously fulfils a buffer function for downstream line modules.

Traysealers	Roller conveyor	Belt conveyor	Intralox transport conveyor	MTC	Compensation conveyor	Continuous	Cyclically
T 300	•		•				
T 300 H			•	•			
T 300 with converging			•			•	•
T 600			•	•		•	
T 700 XS		•		•		•	•
T 700 XS, 2-track with integrated line converger			•		•	•	•
T 700 S		•		•		•	•
T 700 S, 2-track with integrated line converger			•		•	•	•
T 700		•		•		•	•
T 700, 2-track with integrated line converger			•		•	•	•
T 800 S		•				•	•
T 800 S, 2-track with integrated line converger			•		•	•	•
T 800		•				•	•
T 800, 2-track with integrated line converger			•		•	•	•
T 850			•			•	•
T 850, 2-track with integrated line converger			•		•	•	•

Upgrades and options

Labelling and marking systems, as well as inspection systems and the majority of the accessories for your packaging machine, are developed and manufactured by MULTIVAC itself. In this way we can guarantee first-class quality for each system and also ensure that these modules fit seamlessly into the overall system.

Marking systems	34
-----------------	----

Inspection systems	34
--------------------	----

Accessories for more ergonomics	36
---------------------------------	----

Marking systems

MULTIVAC Marking & Inspection, our Center of Excellence for labelling, marking and inspection, offers a large selection of labelling and printing systems for in-line and stand-alone applications.

Our specialists work together with you to develop the ideal solution for your requirements.

- Direct web printers
- Conveyor belt labellers
- Link chain labellers
- Semi-automatic labellers

▼Conveyor belt labeller



Inspection systems

MULTIVAC Marking & Inspection also offers a comprehensive range of systems for the quality inspection of products and packs. These ensure that your products meet the highest quality and safety standards.

- Checkweighers
- Metal detectors
- X-ray inspection systems
- Visual inspection systems

▼ Checkweigher





Accessories for die change

Traysealers	Changing trolley	Changing trolley with service function	Service station	Changing trolley with storage space for a second die.	Shelving system	Shelving system with integrated preheating station
T 300				•		
T 600				•		
T 700 XS	•	•			•	•
T 700 S	•	•			•	•
T 700	•	•			•	•
T 800 S	•	•			•	•
T 800	•	•			•	•
T 850	•		•		•	•

Accessories for more ergonomics

In order to make your packaging procedures even more ergonomic, we offer a comprehensive range of accessories which simplify die change and film transport. We also provide shelving systems for storage of your dies.

Die changing trolley

During die change, the die changing trolley is loaded with the die top section, die bottom section, gripper and die mould parts. It is mobile, lockable and can be used as storage space.

Die changing trolley with service function

In the case of the die changing trolley with service function, the die top section can also be turned for servicing and cleaning work.

Service station

The service station is used to turn the die top section of the T 850 for servicing and cleaning. The die is brought into the service station by the die changing trolley.

Die changing trolley with storage space for a second die

The die changing trolley for the T 300 is loaded with up to two die top sections and the associated tray carriers, tray removers and filling plates. It is mobile and lockable. At the same time, it can also be used as storage space for dies.

Shelving system

The shelving system serves as proper storage for die sets which are not being used, including all the associated die parts such as grippers and tray carriers. The die is deposited by the die changing trolley in the shelving system. The shelving system can be extended to meet individual requirements.

Shelving system with integrated preheating station

The die top section is preheated by the preheating station to a temperature of up to 60°C. This means that it can be brought up to operating temperature in the traysealer more quickly, thus reducing the machine downtime during format change.



Better Packaging with MULTIVAC

If you decided to purchase a MULTIVAC, you will receive individually tailored packaging solutions, reliability in the packaging process and excellent service.

Our wide and flexible product range enables us to supply a machine to you with the output, functionality and flexibility, to meet your requirements.

Take advantage of our consulting services and benefit from our many years of experience in developing solutions for packaging food.

Simply ask us!

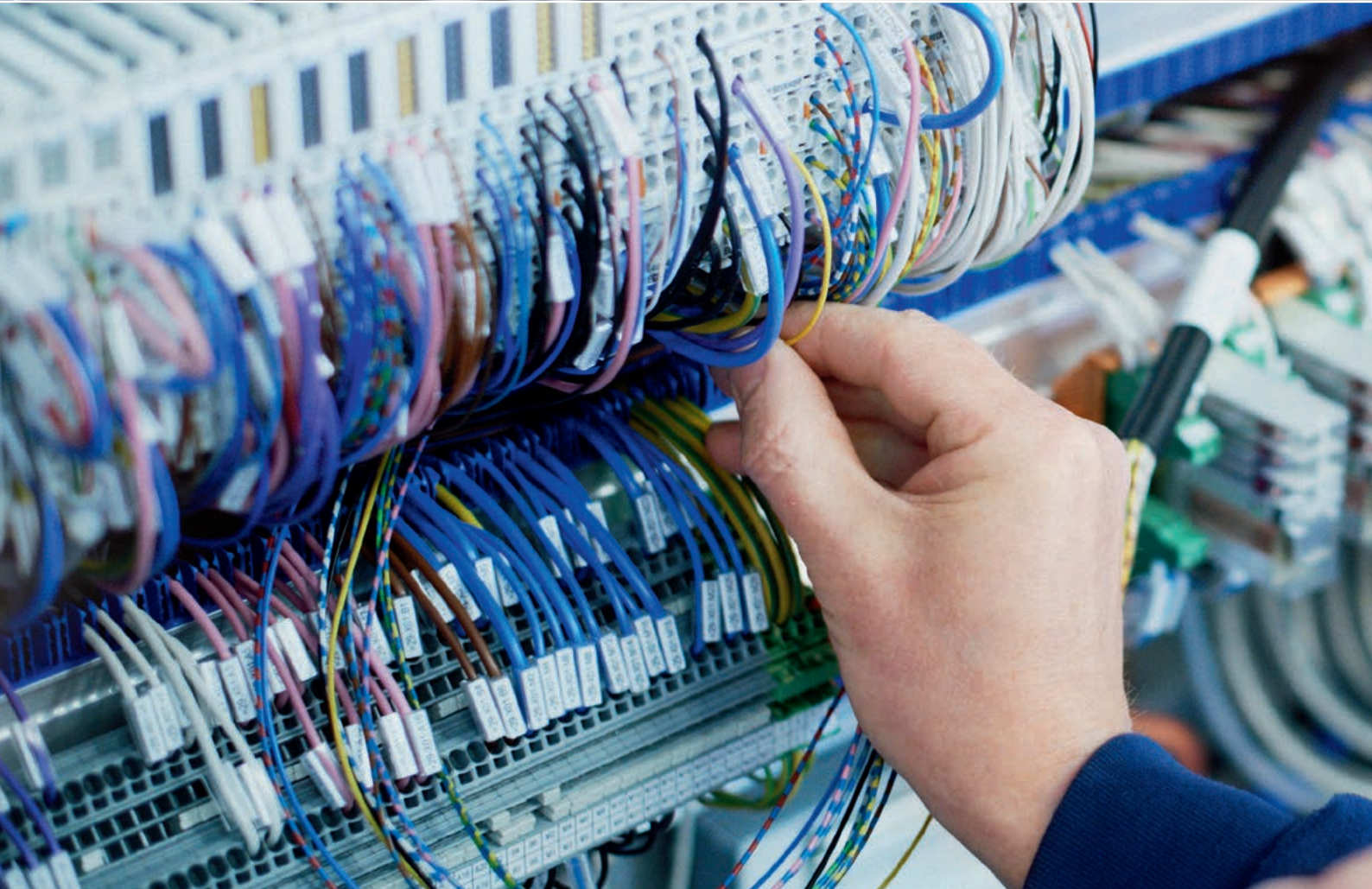

When it comes to security, it means everything!

When we develop and manufacture our packaging solutions, our primary focus is a fault-free and smooth packaging procedure for our customers.

MULTIVAC offers

- a reliable machine design
- maximum hygiene
- simple operation
- rapid availability of spare parts
- comprehensive service

Easy machine operation with HMI 2.0

Simple operation is critical for process reliability. The HMI 2.0 operating interface with touchscreen display is intuitive to use, thanks to its graphical user interface. Calling up a recipe is sufficient for controlling all modules of a line. In this way, operator errors can be avoided. Thanks to the individual management of operating rights, an operator only has access to those parameters which are relevant to him. All settings and important production data are automatically logged. Faults in the packaging procedure can therefore be traced back to their cause.

Logon with chip card

Operators can logon and logoff quickly with this option. The registration takes place without contact. It is sufficient to hold one's personal chip card to the machine control briefly.

Start/stop without contact

A sensor, which operates without contact, enables the machine to be started and stopped without the operator coming into contact with it.



MULTIVAC Hygiene Design™

MULTIVAC traysealers featuring the MULTIVAC Hygiene Design™ are designed for the hygiene requirements of the food industry. Hygienic design and high-quality materials ensure reliable and fast cleaning. The smooth, angled external surfaces without recesses, corners or edges are easy to clean. The modules inside the machine are also optimized for hygiene, such as the tray transport system, the conveyors removable without tools and all format-dependent parts.

Due to the large doors and safety guards, the entire tray packaging process is visible and easily accessible for cleaning and service work.

MULTIVAC Tray Sealers

- Certified in accordance with DIN EN 1672-2-2005,
- Certified in accordance with DIN EN 14159.2008,
- Can be equipped, as an option, in accordance with the USDA hygiene standard.

Advantages

- Shorter cleaning and servicing times, therefore less downtime
- Easy access to all important components
- Saving use of water and cleansers
- Longer lifespan of the packaging machines
- GS certification mark of the German Social Accident Insurance (DGUV)

More service

Service from MULTIVAC covers the entire life cycle of a packaging solution. Over 900 specialists worldwide support you with consultations, training and technical service.

Professional consultancy and machine installation

The packaging specialists from MULTIVAC analyze existing packaging concepts and highlight potential for improvement. They develop new packaging and suitable machine concepts with you. They also ensure that your new packaging machine is put into service without a hitch and that it is integrated in your production process.

Tests of packaging solutions in the MULTIVAC Innovation Centers

We provide capacity in our Application Centres for you to perform packaging tests. Here you have the opportunity to test packaging concepts, as well as produce small quantities for conducting market acceptance studies. Shelf life tests and technical food analysis can also be performed.

Needs-based training courses

We offer user training courses worldwide for our customers' operators and service personnel. Training is also offered on site at customer locations, at daughter company locations or at the MULTIVAC Training & Innovation Center. We are flexible in matching the content of our training courses to your requirements.

Machine maintenance

Thanks to the benefits of reliable machine technology, our technical service always ensures that the maximum availability of your equipment is maintained. The simple and quick supply of spare parts makes a significant contribution to this. The expertise of our specialists make this service perfect.

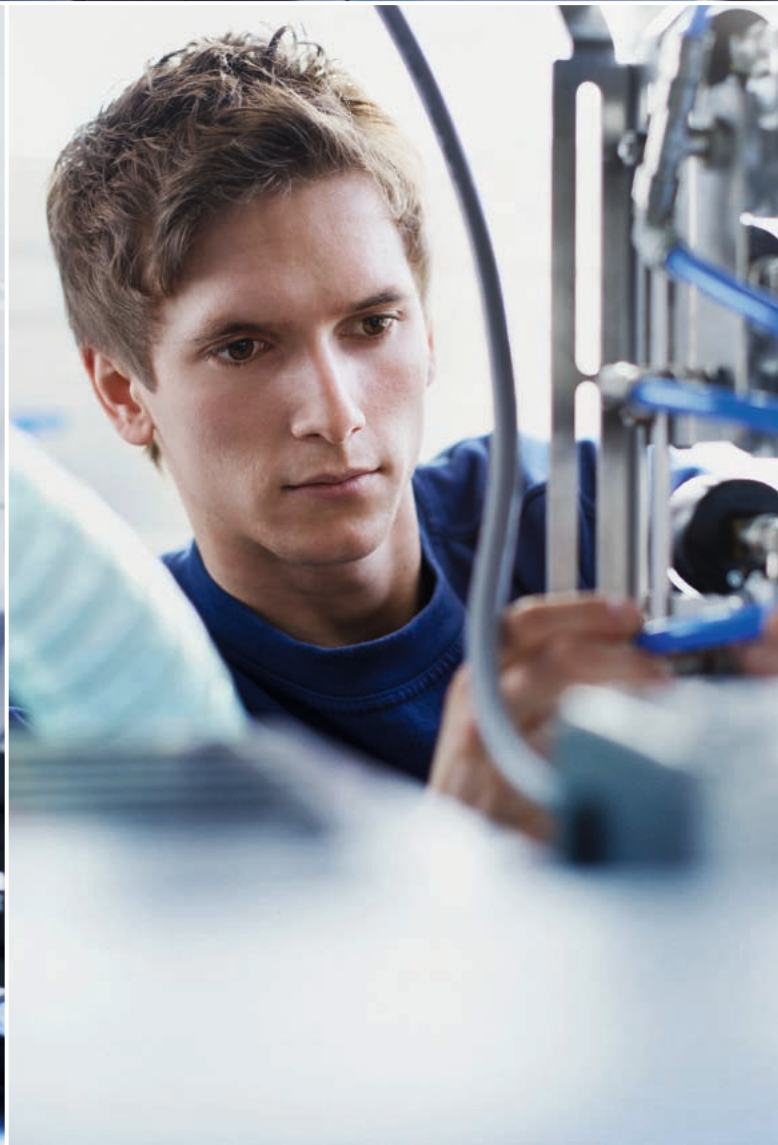

Complete turnkey packaging lines from one source

MULTIVAC develops and manufactures turnkey packaging lines, including infeed equipment, handling modules, convergers, inspection systems, labelling and marking equipment as well as outer packaging systems. All the modules of a line can be controlled centrally via the MULTIVAC HMI user interface. The MULTIVAC machine control enables process data to be processed seamlessly for later use, for product traceability.







BETTER PACKAGING

MULTIVAC offers integrated solutions for packaging. We serve customers worldwide with our wide range of machines and services. Our decentralized organization is the basis for our individual customer care.

