

# AUTOMATIC HYDRAULIC PISTON FILLER/STUFFER



## FPT30e

All in One:

- Filler/Stuffer
- Portioner
- Twister/Linker

**30 litres capacity:**  
*Quick product  
changeover  
without waste.*



Market Leader in the Global Food Industry



**All digital:**  
*Using advanced IO-Link  
internal communications  
for precise portioning.*



## At work

- Various assistance systems help the user to find the most efficient way to the desired product.
- Intuitive calibrating system to produce exact weight portions in relation to density of the product.
- Nozzle adjustable twisting, manual casing hold.
- Clear visual indication of remaining product.
- Counters for batch/total number and weight.

### Filling mechanics

- 3 working modes: straight fill, portion and twist.
- Single or continuous operation, programable number of portions for automatic stop.
- Portions from 5 g up to 25 kg, very precise: only  $\pm 1$  g.
- Very fast, can produce up to hundreds of portions per minute.
- Number of nozzle twist adjustable from 1-15 revs.
- Programable fill break.

### All stainless steel frame

- Very robust construction.
- Completely stainless: entire frame, external and internal, in AISI304, as well as all possible hardware and components.
- Polished surfaces without corners, with  $\text{C}\ddot{\text{e}}$  radius to facilitate cleaning and comply with hygiene standards.
- Double sealed waterproof access panels.
- Closed machine bottom.
- Adjustable, stainless steel machine feet, non-slip and vibration absorbing.

## Industry 4.0 Digital solutions for the food industry



### TalsaConnect

#### Remote Service & Support Access

Realtime access to machine from anywhere:

- Operator support & education
- Configuration, adjustments
- Troubleshooting

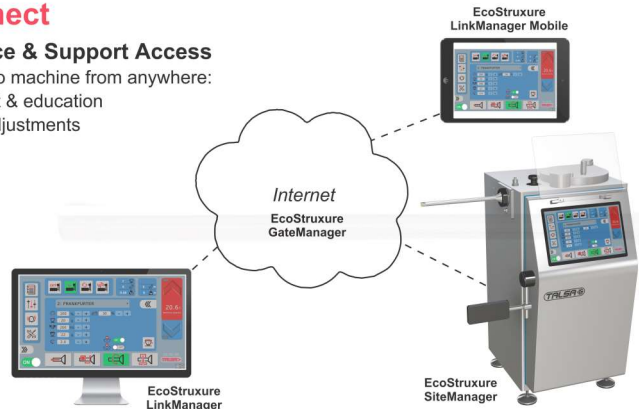

## Hydraulics, electrics and electronics

- Powerful motor, high hydraulic pressure, for the densest or coldest products.
- Hydraulic/electric components of first brands Hydac Germany and Schneider Electric.
- Temperature controlled oil cooling system.
- Easy access to electric panel.
- Very reliable and precise electronic internal digital communications using advanced new I/O Link industry standard components Balluff Germany brand. **BALLUFF**



## External communications

- Industry 4.0 digital solutions for maintenance, process integration and custom solutions.
- Remote Service and Support access over secure internet connection. (router/ethernet cable or mobile phone)

## Software

- Control panel with large 15" Schneider Electric digital touch screen, all information displayed simultaneously and in large size.
- Extensive information on controls, alarms, errors, diagnostics.
- Very advanced and practical software with numerous options. Intuitive, easy to use.
- Interactive recipes, can be stored and executed directly on the machine's screen.





Large 15" touch screen.



Optional: curved nozzle to fill cans/jars.



Optional: 4 swivel casters with brake.

### Technical specifications FPT30e

Barrel capacity	Litres	30
	Gallon	8
Meat capacity	kg	± 25
	lbs	± 55
Power	kW	2.2
	HP	3.0
Max. consumption	400/380 V	A 7.5
	230/220 V	A 12.1
Machine net weight	kg	± 374
	lbs	± 825

### Packaging

Dimensions (wooden crate)	cm	90x70x130
	Inch	36"x28"x52"
Volume		0.82 m <sup>3</sup>
Gross weight	kg	± 470
	lbs	± 1,035

### STANDARD DELIVERY

5 nozzles, ext. Ø 14, 20, 30, 38 and 43 mm.  
 • Hydraulic oil • Piston extraction wrench.

### Dimensions

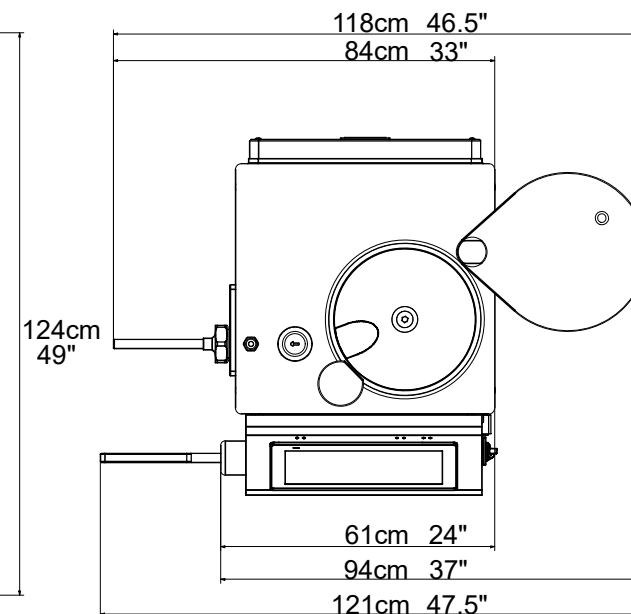
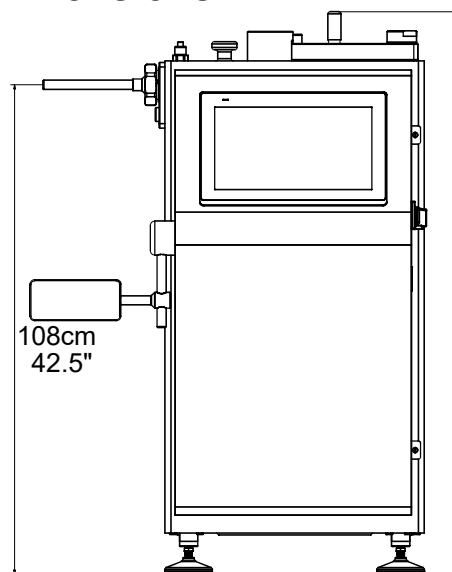

**Talsabell s.a.**   
 Valencia - Spain  
 www.talsanet.com



Dimensions and illustrations are not binding. We reserve the right to make changes.

Your authorized TALSA dealer: