

XTRAVAC

Providing Quality with Economical Solutions

Multihead Weigher Packaging Systems

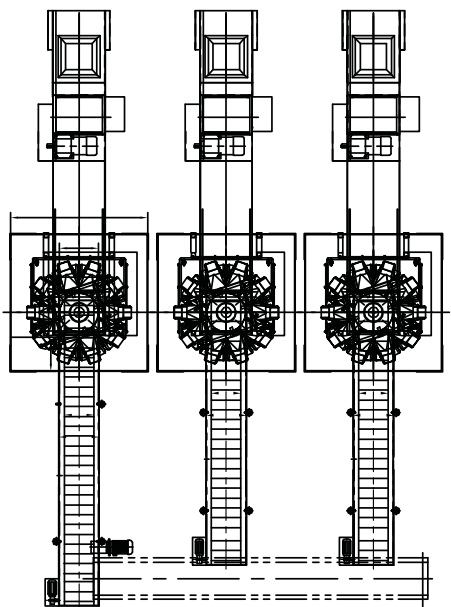
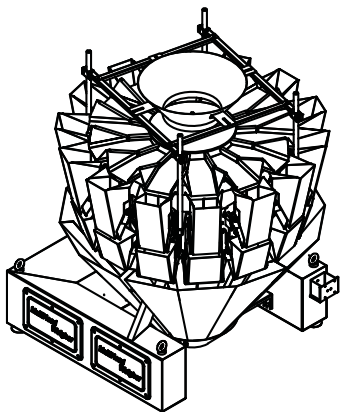

XTRAVAC

Providing Quality with Economical Solutions

Canada

877-435-4555 • Sales.Canada@XtraVac.com

United States

800-728-2999 • Sales@XtraVac.com

Mexico

+52 81 8361 3178 • Sales.Mexico@XtraVac.com

Americas

+57 310790 9057 • Sales.Americas@XtraVac.com

XtraVac Offers a Complete Line of Packaging Machines & Equipment

XTRAVAC

Providing Quality with Economical Solutions



Multihead Lines Make Packaging Options Endless

XtraVac Multihead packaging lines offer unsurpassed accuracy and efficiency with models that meet a full range of production speeds. Line integration, operation, maintenance are a snap. Plus, machine controls are simple and intuitive.

- Perfect for:
- Bulk powder
 - Grain/Rice
 - Shredded/Crumbled Cheese
 - Granular Materials
 - Diced Produce
 - Pasta
 - Candy
 - Chips/Snacks
 - Fresh or Dried Fruit
 - Frozen Foods

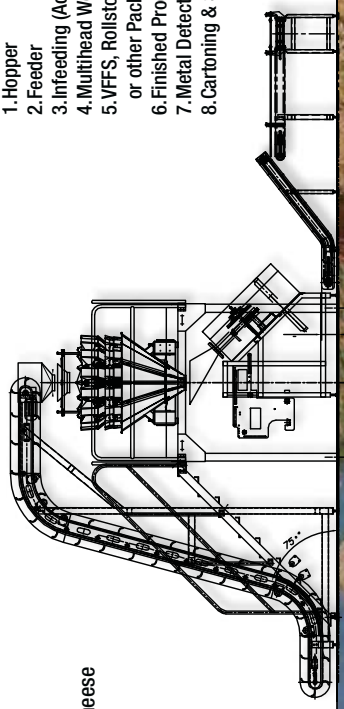

Standard Multihead Packaging Line

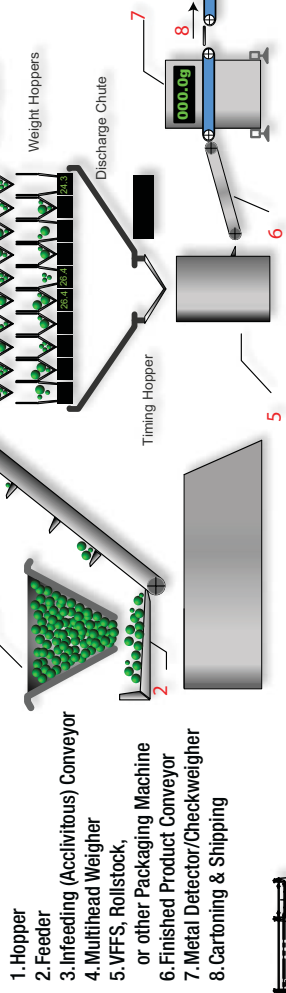

1. Hopper
2. Feeder
3. Infeeding (Accipitous) Conveyor
4. Multihead Weigher
5. VFFS, Rollstock, or other Packaging Machine
6. Finished Product Conveyor
7. Metal Detector/Checkweigher
8. Cartoning & Shipping



- ### Hopper & Feeder Units
- Vibrates to gently move products
 - Speed controllable
 - Stainless steel construction
 - Hygienic designs for easy washdown

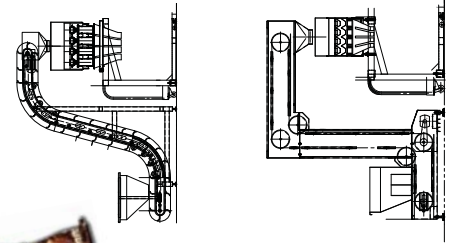

Infeding Conveyor Units

- Belted, Accipitous, Elevator, and Screw Type Conveyors
- Models designed for every product consistency (powders, sticky, granular, brittle, etc)
- Surfaces include PU Belt, Stainless, Dimpled



Visit **XTRAVAC.com** or call **800-728-2999**

Providing Quality with Economical Solutions

XTRAVAC

Providing Quality with Economical Solutions

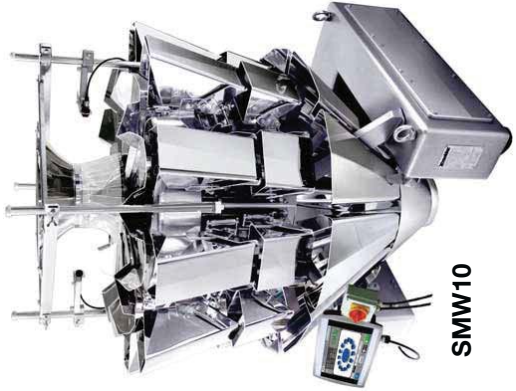

SMW10
Standard
Multihead Weigher
10 Head

Multihead Weigher Units

XtraVac Multihead Weighers are perfect for accurately portioning almost any type of bulk products into easily transported, saleable packages.

- **Head Weigher Amt.**
10, 14, or 24
- **Hopper Bucket Size**
1, 1.3, or 2.5 Liter
- **Bucket Finish**
Smooth or Dimpled
- **Portioning Speed**
Up to 120 WPM

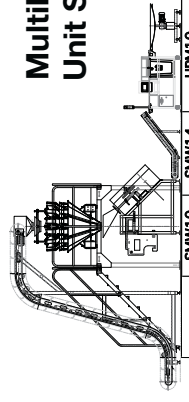
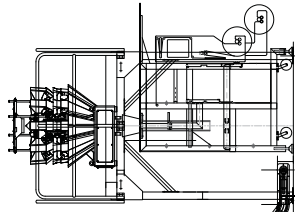

SMW14
Standard
Multihead Weigher
14-Head

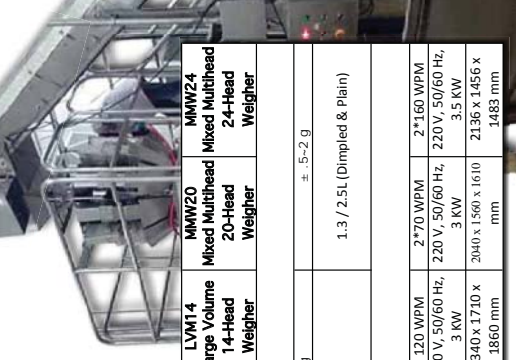

LVM10
Large Volume
Multihead Weigher
10-Head

Multihead Weigher Unit Specifications

Options & Features	SMW10 Standard 10-Head Weigher	SMW14 Standard 14-Head Weigher	HPM10 High Precision 10-Head Weigher	HPM14 High Precision 14-Head Weigher	LVM10 Large Volume 10-Head Weigher	LVM14 Large Volume 14-Head Weigher	MMW20 Mixed 20-Head Weigher	MMW24 Mixed 24-Head Weigher
Weighting Range	25 ~ 500 g							
Accuracy	± 0.5 ~ 2 g							
Hopper volume	1.3L (2.5L double door option)	± 3 ~ 8 g	± 1 ~ 3 g	5.5 L	1.3 / 2.5L (Dimpled & Plain)			
Display Interface	10.4 inch color touch screen							
Max.speed	75 WPM	120 WPM	120 WPM	120 WPM	60 WPM	120 WPM	2*70 WPM	2*160 WPM
Power supply	220V, 50Hz, 1.5KW	220V, 50Hz, 2KW	220V, 50/60 Hz, 1 KW	220 V, 50/60 Hz, 1.2 KW	220 V, 50/60 Hz, 2KW	220 V, 50/60 Hz, 3 KW	220 V, 50/60 Hz, 3 KW	220 V, 50/60 Hz, 3.5 KW
Dimension (mm)	1500 x 1120 x 1400 mm	1600 x 1210 x 1550 mm	1336 x 930 x 1146 mm	1236 x 936 x 1113 mm	1900 x 1266 x 1900 mm	2340 x 1710 x 1860 mm	2040 x 1560 x 1610 mm	2136 x 1456 x 1483 mm

SMW10
Standard
Multihead Weigher
10 Head



SMW14
Standard
Multihead Weigher
14 Head



LVM10
Large Volume
Multihead Weigher
10 Head

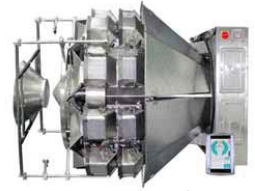

LVM14
Large Volume
Multihead Weigher
14 Head



HPM10
High Precision
Multihead Weigher
10 Head



HPM14
High Precision
Multihead Weigher
14 Head



MMW20
Mixed
Multihead Weigher
20 Head



MMW24
Mixed
Multihead Weigher
24 Head



XTRAVAC
Providing Quality with Economical Solutions
Visit XtraVac.com
or call **800-728-2999**



XTRAVAC

Providing Quality with Economical Solutions



VFFS Vertical Form Fill Seal Units

Rolls of material are pulled through a form and sealed to form the bag. The Multihead unit sits just above the VFFS machine. Products are weighed/portioned and dropped immediately into the bag. The bag is sealed and dropped onto the exit conveyor.

- Adjustable bag depth to accommodate multiple weights, portions, and products
- Quick changeovers between products eliminates wasted time
- Stainless steel construction
- Hygienic design for washdown and sterilization
- Safe for almost any packaging environment
- Smooth or Dimpled surfaces easily accommodate dry or sticky products
- User-Friendly interface for easy control and modification
- Web widths range from 400 to 1200 mm and larger units are available

XTRAVAC
Providing Quality with Economical Solutions

Visit
XtraVac.com
or call
800-728-2999

Weighed/Portioned Product is
Dropped into Bag by Multihead Unit.

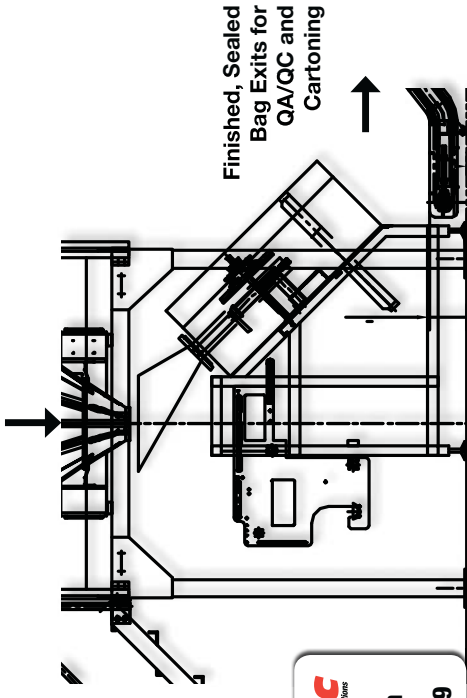

Ultra Large Bag
VF1000UL, VF1200UL



Medium Speed
VF500M, VF620M, VF800M



Incline Series
VF500I, VF620I



High Speed Series
VF400HS



High Speed Series
VF500HS



High Speed Series
VF620HS

XTRAVAC

Providing Quality with Economical Solutions

Take Away & Collection

1. Easily lift finished products to a ergonomic height.
2. Carry them through checkweigher and/or metal detector inspection.
3. Collect them for quick cartoning and transport to market.

- Stainless steel construction
- Hygienic design for washdown and sterilization
- Safe for almost any packaging environment
- Cross-Machine control for easy control and line modification



Take Away
Conveyor



Flat Standalone
Conveyor



90° Curved
Conveyor



Rotary
Collecting
Table



XTRAVAC

Providing Quality with Economical Solutions

Canada

877-435-4555 • Sales.Canada@XtraVac.com

United States

800-728-2999 • Sales@XtraVac.com

Mexico

+52 81 8361 3178 • Sales.Mexico@XtraVac.com

Americas

+57 310790 9057 • Sales.Americas@XtraVac.com

XtraVac.com

A DIVISION OF
INAUEN GROUP

VC999
PREMIUM PACKAGE

XTRAPLAST
BEST SOURCE for packaging materials.

XTRAVAC
Providing Quality with Economical Solutions

Inauen Group

The parent company of XtraPlast,
XtraVac, & VC999 Packaging
Systems

VC999

Innovative packaging machines,
vacuum chamber machines,
robotics and vision inspection
systems

XtraPlast

Your best source for packaging
materials and supplies. Thousands
of stock items & Custom printing
and sizes are Easy

XtraVac

Packaging machines that are
not only economical, but easy to
operate and maintain